

PAPER • OPEN ACCESS

## Arcing fault diagnosis using first peak arrival of EM radiation signal

To cite this article: Melaty Amirruddin *et al* 2021 *J. Phys.: Conf. Ser.* **1878** 012041

View the [article online](#) for updates and enhancements.

You may also like

- [Research on the airflow field and interruption performance of 550 kV fast circuit breaker](#)  
Huancheng Zou, Xin Lin, Jianying Zhong et al.

- [Arc erosion characteristics of cables with heatproof insulations in AC series circuits at low pressure](#)  
Zishan Gao, Rui Yang, Jian Wang et al.

- [Study on arc duration and erosion characteristics of cable electrodes in AC series circuits](#)  
Zishan Gao, Rui Yang, Wenjie Yang et al.



**ECS** The Electrochemical Society  
Advancing solid state & electrochemical science & technology

**ECS UNITED**

**247th ECS Meeting**  
Montréal, Canada  
May 18-22, 2025  
*Palais des Congrès de Montréal*

**Showcase your science!**

**Abstracts due December 6th**

# Arcing fault diagnosis using first peak arrival of EM radiation signal

Melaty Amirruddin<sup>1</sup>, Mohd Rafi Adzman<sup>1</sup>, Nur Adyani Mohd Affendi<sup>1</sup>, Azralmukmin Azmi<sup>1</sup>, Muhd Hafizi Idris<sup>1</sup>, Hana Abdull Halim<sup>1</sup>, Muzamir Isa<sup>1</sup>, Syahirah Abdul Halim<sup>2</sup>

<sup>1</sup>Faculty of Electrical Engineering Technology, Universiti Malaysia Perlis (UniMAP), Pauh Putra Campus, 02600 Arau, Malaysia.

<sup>2</sup>Department of Electrical, Electronic & Systems Engineering (JKEES), Faculty of Engineering and Built Environment, Universiti Kebangsaan Malaysia (UKM).

E-mail: melaty@unimap.edu.my

**Abstract.** The objective of this study was to diagnose the arcing fault signals based on the first peak of arrival method using antenna to assess its use as potential arcing fault detection in power system network. Square patch antenna and circle patch antenna were employed for detection on artificial arcing in real environment. First peak of arcing signal arrival was measured through an analysis over a range of time and amplitude signals detected. For accurate results, Discrete Wavelet Transform (DWT) denoising technique was applied to the arcing signals detected as denoising tools. Analysis of first peak of signal arrival time and amplitude were carried out using MATLAB software to measure the changes in signals detected caused by different placements of antenna. The results revealed that the first peak of signal arrival time, amplitude, type of antenna used and placement of the antenna around arcing source point all reflect the signals measurement.

## 1. Introduction

Detecting and locating faults in the electricity delivery grid is a top priority for utility providers and poses problems that vary from those faced with faults in electricity transmission [1]. Arcing fault is widespread in power system network and is accountable for the most destructive impact of electrical fires. Arcing faults happens once insulation ages or when some factors have been affected. The arcing fault is a luminous high-power discharge between two electrical contacts, this discharge is the primary cause of the leakage of an immense quantity of energy to the surrounding environment, destroying the circuits and, at times, absorbing a large portion of the conductors. The transient aspect of the arcing fault current further aggravate the clearing issue of arcing fault by the traditional overcurrent safety method [2].

Lately, arcing source detection and localization has acquired significant attention in numerous location-based technologies since arcing fault is an essential part to the distribution and outage management system because the occurrence of arcing fault may reduce the outage of the power supply under actual field conditions. Besides, the arcing fault is a popular issue faced in power system network and involves many engineering aspects. Commonly, arcing fault caused by insulation failure due to loose jointing at the terminal, insulation broken or continuous contacting, ageing, mis-operation, moisture present and any natural phenomenon such as lightning and tree leaning on the cable [3]–[5]. Generally, arcing fault detection have been discussed by other researchers, such as [6]–[9], however, effective detecting methods for incipient arc fault are quite few. Additionally, the pre-



fault in the cable cannot be detected by a human, thus, an incipient stage monitoring sensor is needed for precaution method before major breakdown happens.

Therefore, in this work, the compact patch antennas are designed and developed to test the monitoring condition of arcing fault signals. However, some researchers has been reported on [10], the results showed that the measurement will not be accurate due to presence of a discrete spectral interference (DSI) and also white Gaussian noise (WGN). DSI is a narrowband noise occurred from radio broadcast signal while WGN is a broadband noise resulted from measuring instrument itself. Therefore, for accurate arcing fault measurement, Discrete Wavelet Transform (DWT) denoising technique was applied before verification of first peak arrival time of EM radiation arcing signals. Furthermore, two geometrical shapes of square and circle patch antennas are developed to compare each performance characteristics.

## 2. Compact patch antenna as arcing fault sensor

In the first stage, two geometrical shapes of square and circle patch antenna were developed as an arcing fault detection method under Ultra High Frequency (UHF) band. The antennas were designed to obtain the reflection coefficient below  $-10$  dB for better detection and measurement [11]. The antennas modelled are performed in CST Studio Suite software. The optimal parameters designed studies were determined according to the side dimension, feedline dimension, radius, matching impedance, Flame Retardant 4 (FR4) dielectric constant, printed circuit board (PCB) thickness and copper thickness. In order to check the applicability of the antennas to predict the optimum operating frequency and to evaluate the consistency of the measurement, the simulation models were designed as shown in Figure 1 while the parameters of the antennas were listed in Table 1.

The antennas were then fabricated based on the simulation modeling and expected to be able capturing small amplitude of artificial arcing signals from experimental setup [12]. The experiment was conducted under the same testing condition for both different antennas designed.

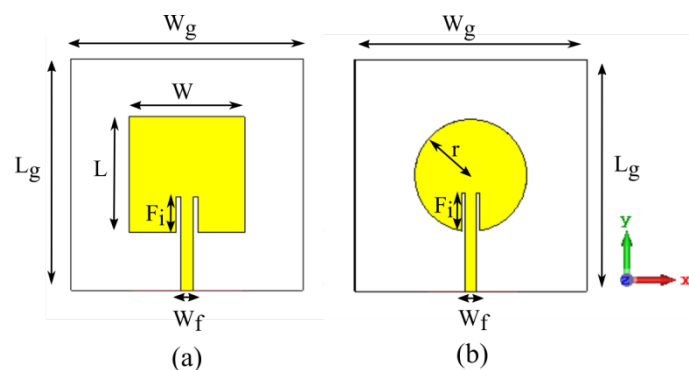

**Figure 1.** Geometry design of (a) square patch antenna (b) circle patch antenna.

**Table 1.** Parameters of each antenna.

Antenna Geometry	Square Patch Antenna	Circle Patch Antenna
Ground width, $W_g$ (mm)	50.3	60
Ground length, $L_g$ (mm)	50.3	60
Width, $W$ (mm)	25.15	30
Length, $L$ (mm)	25.15	30
Feedline length, $F_i$ (mm)	7.8	10.2
Feedline width, $W_f$ (mm)	2.84	2.85
Radius, $r$ (mm)	–	15
Impedance matching ( $\Omega$ )	50	50
FR4 dielectric constant, $\epsilon_o$	4.3	4.3
PCB thickness (mm)	1.6	1.6
Copper thickness (mm)	0.0035	0.0035

### 3. DWT denoising technique

DWT is a wavelet transformation which the wavelets are discretely sampled in numerical analysis and functional analysis. The wavelet transformation in mathematical functions is used to decompose the signal into components of high and low frequency. The wavelet coefficients are calculated to measure the frequency content resemblance between a signal and a selected wavelet function. These coefficients are calculated as a signal convolution in the scaled wavelet function. DWT is expressed by (1) [10]:

$$DWT(p, q) = \frac{1}{\sqrt{p}} \sum_n x(n) \psi^* \left( \frac{n-q}{p} \right) \quad (1)$$

where  $n$  represents the discrete number,  $p$  and  $q$  are scaling and translation parameters respectively while  $\psi$  denotes as mother wavelet.

The DWT technique has three essential procedures to validate the optimum denoising process and effectively perform noise suppression on the noisy arc fault signal. The procedures comprise decomposition, thresholding variation, and reconstruction. Figure 2 illustrates the denoising procedure of DWT technique.

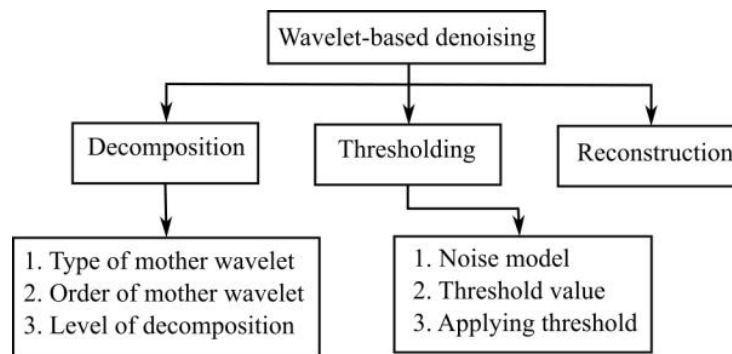

**Figure 2.** Wavelet based denoising procedure [13].

In this study, mother wavelet, Debauchies 13 (db13) was used for noise reduction improvement by referring to [10]. This paper further evaluates the denoising performance through more in-depth analysis the application towards arcing signal detection.

### 4. Modelling and Simulation

The main components for experimental setup was carried out using the four antennas developed for each geometrical shape, high voltage alternating current (HVAC) power supply and pressure test (BAUR70). The four antennas were connected to a Lecroy Wavesurfer 3024 digital oscilloscope as measuring tools to capture the arcing signals radiated. The experiment setup was conducted in high voltage laboratory. Figure 3 and Figure 4 show the illustration of the experiment conducted.

Firstly, to form the artificial arcing fault, the high electrical potential was injected by the HVAC and excited using BAUR70 to the one of the conductor above the breakdown voltage. Theoretically, the average breakdown voltage ranges from 25 kV/cm to 30 kV/cm and depends on the insulating material, the edge of the tip of the conductor, and the gap between two conductors [14]. The copper rods used in this experiment indicate the power cables which arcing fault signal travels on it. The gap between primary and secondary copper rods was 1 cm each other and the tip of each rod was 30°.

In order to evaluate the performance of the proposed method, a set of arc location placement was performed as depicted in Figure 5. The setup comprises of four antennas placed around the arc source point covering the EM radiation space. The experiment is repeated concurrently based on the square and circle patch antennas. Signals data were collected approximately four times. Captured signals were recorded as a function of time in order to deduce a direct connection between the location of antennas and first peak arrivals signal.

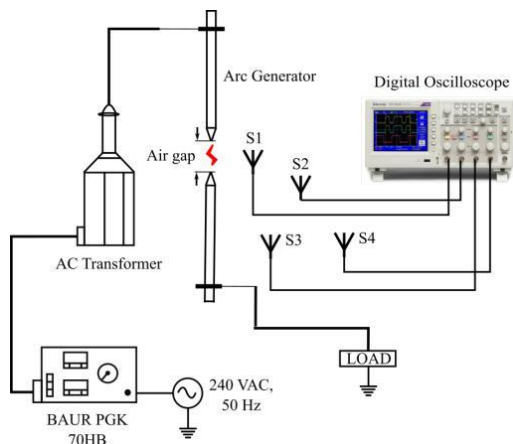

**Figure 3.** Illustration of arc generator experiment setup.



**Figure 4.** Laboratory arc generator experiment setup.

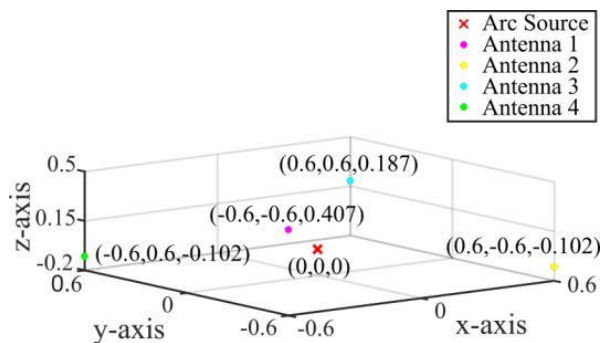
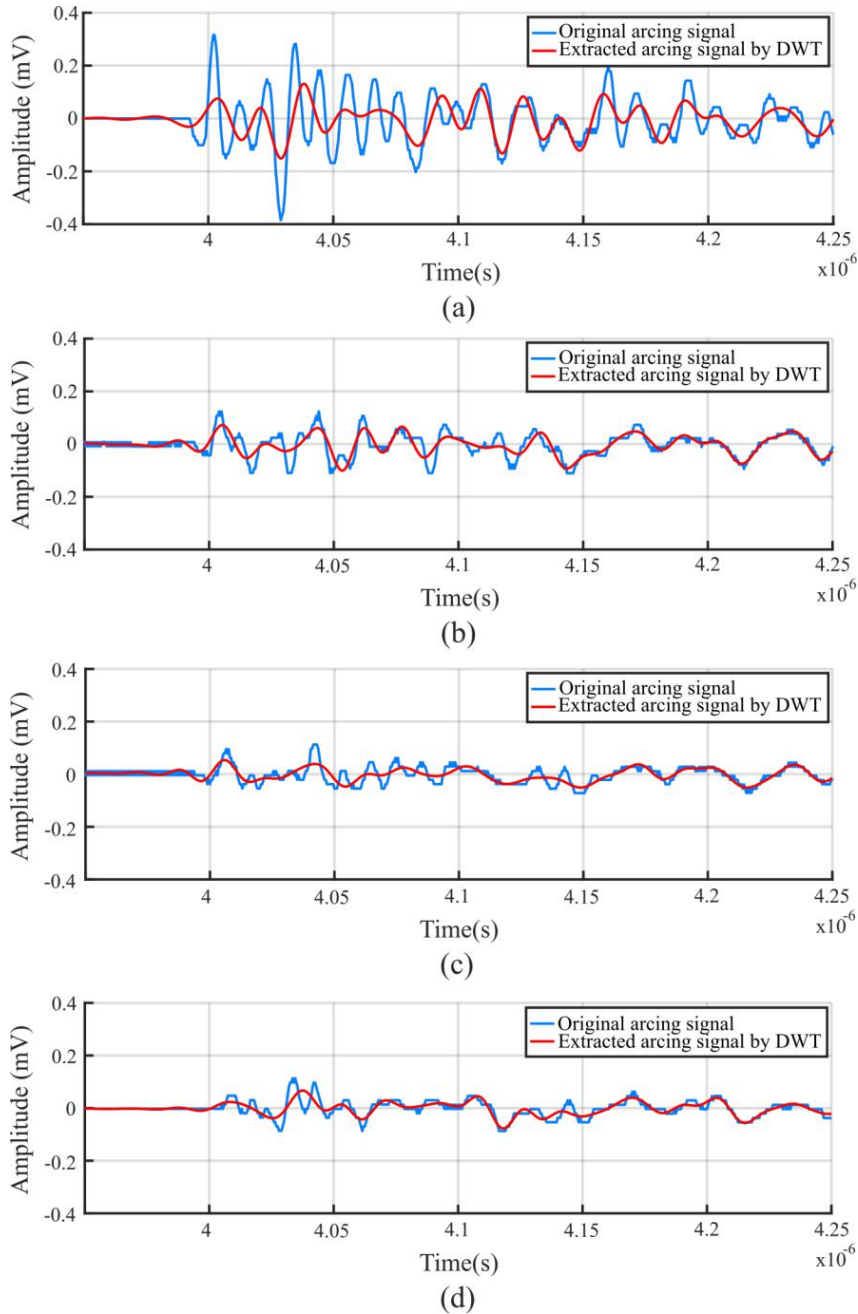

**Figure 5.** Four antennas and arcing source point coordination.

The DWT denoising techniques analysis was applied to the captured data signals using mother wavelet, db13 in order to obtain more accurate results of arcing signals characteristic. The signals after applying DWT denoising technique were analysed again using first peak arrival method programmed by MATLAB software. Figure 6 and Figure 7 show the differentiation of original signal and denoising signal between square patch antenna and circle patch antenna respectively.

Table 2 presents the results of first peak arrival amplitude before and after applying denoising technique. As can be seen, the time of arcing fault signal is decreased for both geometrical shapes of antennas. For square patch antenna, the first peak arrival amplitude for antenna 1 before denoising experiencing a decline from 0.3214 to 0.0312 for antenna 4 while for circle patch antenna, the first peak arrival amplitude for antenna 1 before denoising experiencing a decline from 0.461 to 0.1132 for antenna 4. After DWT denoising techniques was applied, the performance of square patch antenna for antenna 1 is 0.0974 drop to 0.0152 for antenna 4 while for circle patch antenna, antenna 1 is 0.1783 drop to 0.063 for antenna 4. This results show the decrease in amplitude parameter.

Another result that was presented in table 3 is first peak arrival time before and after applying denoising technique. As can be seen, for square patch antenna, the first peak arrival time for antenna 1 before denoising is 4.0005 s faster than antenna 4 that is 4.0113 s while for circle patch antenna, antenna 1 is 4.0006 s earlier than antenna 4 that is 4.0134 s. After applying DWT denoising technique, the performance of square patch antenna for antenna 1 is 4.0007 s detected faster than antenna 4 that is 4.0101 s while for circle patch antenna, antenna 1 is 4.0009 s detected faster than antenna 4 that is 4.0192 s.



**Figure 6.** Original and denoised arc signal for square patch antenna (a) antenna 1 (b) antenna 2 (c) antenna 3 (d) antenna 4.

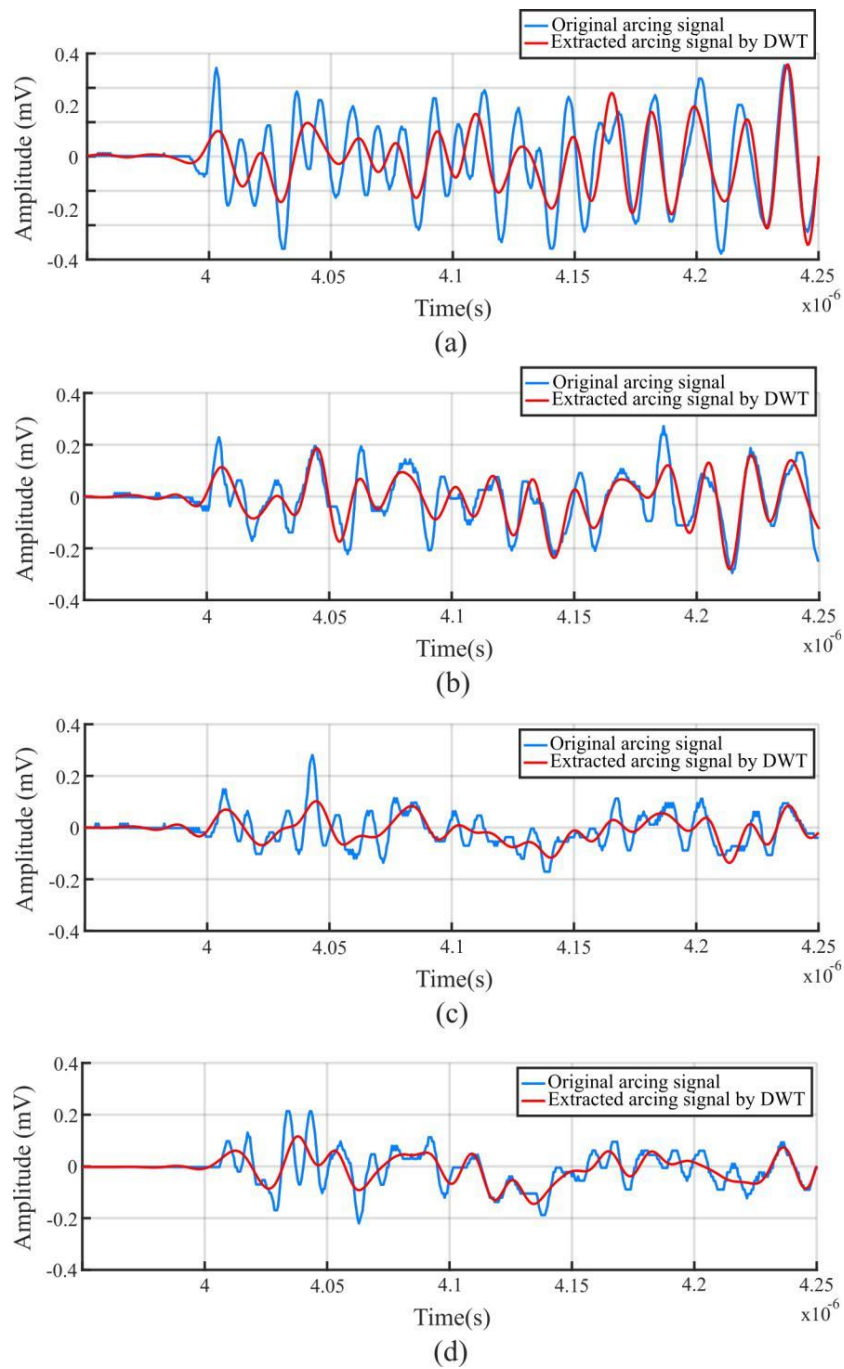

**Figure 7.** Original and denoised arc signal for circle patch antenna (a) antenna 1 (b) antenna 2 (c) antenna 3 (d) antenna 4.

**Table 2.** Results of first peak of EM radiated arcing signals arrival amplitude before and after applying DWT denoising technique.

Amplitude	Square Patch Antenna				Circle Patch Antenna			
	Ant 1	Ant 2	Ant 3	Ant 4	Ant 1	Ant 2	Ant 3	Ant 4
Before denoising	0.3214	0.143	0.1152	0.0312	0.461	0.2211	0.184	0.1132
After denoising	0.0974	0.0876	0.0633	0.0152	0.1783	0.1213	0.0884	0.063

**Table 3.** Results of first peak of EM radiated arcing signals arrival time before and after applying DWT denoising technique.

First peak of arrival time (s)	Square Patch Antenna				Circle Patch Antenna			
	Ant 1	Ant 2	Ant 3	Ant 4	Ant 1	Ant 2	Ant 3	Ant 4
Before denoising (s)	4.0005	4.0073	4.0095	4.0113	4.0008	4.0013	4.0078	4.0134
After denoising (s)	4.0007	4.0088	4.0099	4.0101	4.0009	4.0019	4.0089	4.0192

Based on these observations, these experiments have illustrated two things which are the different of first peak of arrival amplitude and time depending on the distance of each antenna from arcing source point. The closer the antenna distance to the arcing source point, the amplitude is higher and the time of EM radiated signals detected is faster and vice versa. The used of DWT denoising technique is also effected and have slightly different from results before applying DWT denoising technique. The DWT denoising technique has been applied to the arcing signals detected in order to extract the unwanted noised captured, therefore the arcing signals diagnosis can be done precisely. Furthermore, the different used of geometrical shapes of antenna towards arcing signals detected which were square patch and circle patch antennas do not significantly affect the measurement data, both of the antenna performances have slightly different measurement since the performance of the antennas depending on the design of the antennas itself. The antenna can detect and measure the signals better if the antennas were designed to obtain the reflection coefficient below  $-10$  dB.

## 5. Conclusion

This work was devoted to assess the capability of square patch and circle patch antenna to measure arcing EM radiated signals. This was performed by investigating the effects toward first peak of arrival amplitude and time. It was found that antenna 1 for both geometrical shapes of antenna had the greatest influence on first peak of arrival amplitude and time since the distance of antenna 1 to the arcing source point is the nearest position followed by antenna 2, antenna 3 and antenna 4. The results obtained after applying DWT denoising technique was also gave the same trends, which indicates the precise arcing fault diagnosis.

## Acknowledgments

The authors would like to acknowledge Faculty of Electrical Engineering Technology, Universiti Malaysia Perlis (UniMAP) for the funding of this work.

## References

- [1] R. M. Harris, M. D. Judd, P. J. Moore, and J. Livie, *Radiometric detection and analysis of arcing faults*. IEEE Trans. Dielectr. Electr. Insul., vol. 22, no. 3, pp. 1547-1558, 2015.
- [2] C. J. Kim, *Electromagnetic radiation behavior of low-voltage arcing fault*. IEEE Trans. Power Delivery vol. 24, no. 1, pp. 416-423, 2009.
- [3] R. Mendler, R. Hasan, J. Trolle, and N. L. Mina, *Hazardous-Rated Electrical Equipment and the Arc-Flash Hazard*. vol. 51, no. 5, pp. 4335-4341, 2015.
- [4] X. Liang, S. Member, B. Bagen, S. Member, D. W. Gao, and S. Member, *An Effective Approach to Reducing Arc Flash Hazards in Power Systems*. vol. 52, no. 1, pp. 67-75, 2016.

- [5] L. Xu et al., *The Degradation of 10kV XLPE Cable Accessories under Switching Impulses*. 2018 12th Int. Conf. Prop. Appl. Dielectr. Mater., pp. 463-466, 2018.
- [6] Q. Xiong et al., *Series arc fault detection and localization in DC distribution system*. IEEE Trans. Instrum. Meas., vol. 69, no. 1, pp. 122-134, 2020.
- [7] Q. Xiong, S. Ji, L. Zhu, L. Zhong, and Y. Liu, *A Novel DC Arc Fault Detection Method Based on Electromagnetic Radiation Signal*. IEEE Trans. Plasma Sci., vol. 45, no. 3, pp. 472-478, 2017.
- [8] C. Kim and R. Sowah, *Arcing Fault Detection with Experimental Verification using Antenna for Signal Capture of Radiated Electromagnetic Energy*. pp. 1-8, 2009.
- [9] G. A. Hussain, M. Shafiq, M. Lehtonen, and M. Hashmi, *Online Condition Monitoring of MV Switchgear Using D-Dot Sensor to Predict Arc-Faults*. IEEE Sens. J., vol. 15, no. 12, pp. 7262-7272, 2015.
- [10] M. Amirruddin et al., *Evaluation of Denoising Performance for Noisy Arc Fault Signal Based on Mother Wavelet Selection*. 2019 IEEE Asia-Pacific Conference on Applied Electromagnetics (APACE), Melacca, Malaysia, 2019, pp. 1-6, doi: 10.1109/APACE47377.2019.9020995.
- [11] N. A. M. Affendi, M. Amirruddin, S. Ahmad, *Analysis of flexible antenna performance on partial discharges detection*. 2020 Journal of Physics: Conference Series 1432(1), 012066.
- [12] M. Amirruddin et al., *Design of Triangle Loop Antenna for Partial Discharge Impulse Signal Detection*. 2018 IEEE Student Conference on Research and Development (SCORED), Selangor, Malaysia, 2018, pp. 1-6, doi: 10.1109/SCORED.2018.8711338.
- [13] M. S. Ali, A. Halim, A. B. U. Bakar, C. K. Tan, and H. Mokhlis, *Studies on the application of wavelet families for a high impedance fault location*. pp. 5043-5054, 2016.
- [14] J. C. Kim, D. O. Neac, B. Lehman, and R. Ball, *Series AC Arc Fault Detection Using Only Voltage Waveforms*. pp. 2385-2389, 2019.