



**Design of DC High Voltage Low Current Power
Supply Using DC-DC Converter and Cockcroft-
Walton (C-W) Voltage Multiplier**

by

**Nor Afiqah Bt Azmi
(1530311912)**

A thesis submitted in fulfillment of the requirements for the degree of
Master of Science in Electronic Engineering

**School of Microelectronics Engineering
UNIVERSITI MALAYSIA PERLIS**

2018

ACKNOWLEDGEMENTS

In the name of Allah, the most Gracious, the most Merciful.

Alhamdulillah, thanks to Almighty Allah for giving me a chance, strength, courage and patience to complete my research successfully. With His enormous blessing, it is possible for me to undergo this research study.

First and foremost, I would like to take this opportunity to express my sincere gratitude and appreciation to my main supervisor, Ir. Dr. Sohiful Anuar Zainol Murad for giving me guidance, consultation, moral support and leading me through this research. I also would like to give my appreciation to my ex-main supervisor, Prof. Sudhanshu Shekhar Jamuar for his constant attention and motivation during my research progress.

Most importantly, my very special admiration to my understanding family especially my parents and siblings on their love, patience, encouragement and prayers, along this research study.

Special thanks to School of Microelectronics Engineering (SoME), Universiti Malaysia Perlis (UniMAP), and Centre for Graduate Study (CGS) for giving me an opportunity and the guidelines in completing this research.

In addition, I would like to acknowledge the financial support obtained from CREST under the project code P19C1 -14 and the continuous supports by USAINS Infotek and ICE. (Grant no.: 9002-00033)

Lastly, I also grateful to all my friends for their efforts and insightful comments as well as ideas in accomplishing the research. Finally, I would like to extend my gratefulness and special thanks to every individual who directly or indirectly contributed in assisting me throughout this research

Thank you.

TABLE OF CONTENTS

DECLARATION OF THESIS	i
ACKNOWLEDGEMENTS	ii
TABLE OF CONTENTS	iii
LIST OF TABLES	vi
LIST OF FIGURES	vii
LIST OF ABBREVIATIONS	x
LIST OF SYMBOLS	xii
ABSTRAK	xiii
ABSTRACT	xiv
CHAPTER 1 INTRODUCTION	1
1.1 Introduction	1
1.2 Overview of High Voltage DC Power Supply	1
1.3 Problem Statement	4
1.4 Research Objectives	5
1.5 Research Project Scope	6
1.6 Thesis Organization	7
CHAPTER 2 LITERATURE REVIEW	9
2.1 Introduction	9
2.2 High Voltage Generation	9
2.2.1 Deficiency of the transformer design	11
2.2.2 Implementation of DC converter design	12
2.3 Voltage doubler, tripler and quadrupler	14
2.4 Cockcroft-Walton (C-W) Voltage Multiplier	18
2.5 Voltage Multiplier design consideration	19

2.6	Diode and capacitor design specification	20
2.6.1	Capacitor specification	22
2.6.2	Diode specification	23
2.6.3	Input signal frequency	24
2.7	Switching regulator step-up converter	26
2.8	Background design of power circuitry	27
2.8.1	Common controlled method	27
2.8.2	LT1618 Step-up DC-DC Converter	28
2.8.3	LT8331 Boost converter	31
2.9	Voltage regulation	34
2.10	Efficiency of Measurement	36
2.11	Conclusion	37
	CHAPTER 3 RESEARCH METHODOLOGY	38
3.1	Introduction	38
3.2	Flow of Research	38
3.3	Cockcroft-Walton (C-W) Voltage Multiplier Specification	41
3.3.1	Design Implementation	42
3.3.2	Improvement Circuit Design	43
3.4	The Proposed Step-up Converter and Voltage Multiplier	44
3.4.1	LT1618 and LT8331 Step-Up Converter Circuit	46
3.4.2	Voltage Multiplier Circuit	50
3.5	Prototype of High Voltage Power Supply Modules	52
3.5.1	Schematic Circuit Design	52
3.5.2	Layout Circuit Design	52
3.6	Hardware Fabrication and Measurement	55
3.6.1	Printed Circuit Board (PCB) Fabrication	55

3.6.2 Measurement of High Voltage Power Supply Module	58
3.7 Conclusion	62
CHAPTER 4 RESULTS & DISCUSSION	63
4.1 Introduction	63
4.2 LT1618 Step up DC-DC Converter Simulation Results	63
4.3 LT8331 Boost Converter Simulation Results	65
4.4 DC-DC Boost Converter with C-W Voltage Multiplier	66
4.5 Output Power and Load Current Simulation	70
4.6 Efficiency Simulation	73
4.7 Line and Load Regulation Simulation	75
4.8 Experimental Results	79
4.9 High Voltage Power Supply Experimental Works	82
4.10 Measurement Experimental Output Power and Efficiency	85
4.11 Measurement Experimental Line and Load Regulation	90
4.12 Conclusion	92
CHAPTER 5 CONCLUSIONS	93
5.1 Introduction	93
5.2 Conclusion	93
5.3 Recommendation and Future Work	95
REFERENCES	97
LIST OF PUBLICATIONS	103
LIST OF AWARDS	104

LIST OF TABLES

NO.		PAGE
Table 2.1 :	Summary of the LT1618 system performance (Corporation, 2011).	31
Table 2.2 :	Summary of the LT8331 system performance (Corporation, 2015).	31
Table 2.3 :	Preferable R_T value for switching frequency, f_{sw} (Corporation, 2015).	33
Table 3.1 :	Output voltage for different capacitor values and different signal frequencies	42
Table 3.2 :	Voltage drop and ripple voltage for each stage	43
Table 3.3 :	Components requirement for the simulation	49
Table 3.4 :	System specification of the simulation	51
Table 4.1 :	Comparison of output voltage based on calculation, simulation works and laboratory measurement	85
Table 4.2 :	Efficiency summary for the simulation and hardware works	89
Table 4.3 :	Comparison on performances with previous research	90
Table 4.4 :	Comparison between simulation and experimental lines and load regulation measurement values	91

LIST OF FIGURES

NO.	PAGE
Figure 1.1 : Basic high voltage power supply circuit (Bellar et al., 1992).	3
Figure 2.1 : A transformer and voltage multiplier design (Simon & Rasheed, 2016).	10
Figure 2.2 : DC-DC converter design (Naik et al., 2015)	13
Figure 2.3 : Connection series of capacitor diode link for a) voltage doubler circuit and b) output waveform	14
Figure 2.4 : Connection series of three capacitor diode link for a) voltage tripler circuit and b) output waveform	16
Figure 2.5 : Connection series of four capacitor diode link for a) voltage quadrupler circuit and b) output waveform	17
Figure 2.6 : Cockcroft-Walton (C-W) Voltage Mutliplier (Raaj & Rajan, 2013).	18
Figure 2.7 : Output ripple voltage with a load condition and high switching frequency (Katzir & Shmilovitz, 2015).	21
Figure 2.8 : Transient voltage of multiplier with a) 50-60 Hz low input frequency and b) high input frequency (Zabihi et al., 2009).	25
Figure 2.9 : Switching regulator schematic with current-controlled mode	28
Figure 2.10 : LT1618 schematic circuit diagram (Corporation, 2001).	29
Figure 2.11 : LT8331 boost converter circuit (L. T. Corporation, 2015).	32
Figure 3.1 : Process flow of High Voltage Power Supply Modules	40
Figure 3.2 : The proposed dc high voltage power supply module.	45
Figure 3.3 : LT1618 constant voltage or constant current step up dc-dc converter circuit	47
Figure 3.4 : LT8331 circuit inverting converter	48

Figure 3.5 :	Cascading LT1618 and LT8331 connection step-up converter circuit	49
Figure 3.6 :	The proposed 15 stages C-W voltage multiplier schematic	50
Figure 3.7 :	Boost converter with 15 stages C-W voltage multiplier	51
Figure 3.8 :	Schematic circuit design	53
Figure 3.9 :	Layout design a) with a component placement and b) a mirror layout for fabrication process	54
Figure 3.10 :	PCB Fabrication process	56
Figure 3.11 :	Fabricated PCB	57
Figure 3.12 :	15 stages voltage multiplier fabricated circuit a) top view and b) side view circuit	58
Figure 3.13 :	High voltage power supply prototype which constitutes of step up converter and voltage multiplier circuit	58
Figure 3.14 :	a) Electrical setting for high voltage calibration, b) without series resistance and c) with series resistance	59
Figure 3.15 :	Experimental Setup	61
Figure 4.1 :	30 V dc step-up dc-dc converter output	64
Figure 4.2 :	200 V dc boost converter output	66
Figure 4.3 :	Resulting output voltage value from LT 1618, LT8331 and a stage of voltage multiplier	67
Figure 4.4 :	Resulting output voltage value from LT 1618, LT8331 and a stage of voltage multiplier	68
Figure 4.5 :	The 1600 V dc performance output with 100 V dc increment for each applied stage	69
Figure 4.6 :	The current load 0.155 mA value with an applied $R_{load} = 10 \text{ M}\Omega$ at 1550 V	70
Figure 4.7 :	a) Power output and b) load current measurement generated from LT1618	71

Figure 4.8 :	a) Power output and b) load current measurement generated from cascaded LT1618 and LT8331	72
Figure 4.9 :	Cascaded step-up dc-dc converters which linked with 15 stages voltage multiplier a) power output and b) load current measurement.	73
Figure 4.10 :	Measurement on the efficiency of a) LT1618 step-up dc-dc converter and b) cascaded with LT831boost converter	74
Figure 4.11 :	The measured efficiency of 1600 V which is connected with cascaded converter	75
Figure 4.12 :	Line regulation for the circuit design with a) 2 V dc and b) 8 V dc input supply	77
Figure 4.13 :	Circuit design with a)2 V dc input supply and b) 8 V dc input supply circuit design	78
Figure 4.14 :	Load regulation in the circuit design	79
Figure 4.15 :	Prototype measurement of the proposed transformer less dc high voltage power supply module	80
Figure 4.16 :	Prototype measurement of the proposed transformer less dc high voltage power supply module	81
Figure 4.17 :	Measurement value for a 5 V dc input voltage and 30 V dc output voltage through voltmeter reading according to the LT1618 circuit	82
Figure 4.18 :	Measurement value for a connected 30 V dc input voltage with a) 100 V dc and b) 200 V dc output voltage through voltmeter	83
Figure 4.19 :	Measurement value for a connected 100 V dc input voltage with 1600 V dc output voltage through voltmeter.	84
Figure 4.20 :	Measured efficiency of a) LT1618 step-up dc-dc converter and b) cascaded with LT831boost converter	87
Figure 4.21 :	Measured efficiency of 1600 V which is connected with cascaded step-up dc-dc converter	88

LIST OF ABBREVIATIONS

AC	Alternating Current
APD	Avalanche Photodiode
C	Capacitor
C-W	Cockcroft-Walton
D	Diode
DC	Direct Current
DRC	Design Rule Check
ERC	Electronic Rule Check
FB	Feedback
FBX	Feedback pin
f_{sw}	Switching frequency
I	Current
IC	Integrated Circuit
I_{FL}	Full-load current
I_{fsm}	Peak Forward Surge Current
I_{load}	Load Current
ISN	Current surge at negative
ISP	Current surge at positive
LED	Light Emitting Diode
MOSFET	Metal Oxide Semiconductor Field Effect Transistor
MSOP	Mini Small-Outline Package
η	Efficiency
OUT1	Output voltage for simulation 1
OUT2	Output voltage for simulation 2
PCB	Printed Circuit Board
P_{out}	Output Power
PMT	Photomultiplier Tube
PWM	Pulse Width Modulation
R_L	Load Resistance
SMD	Surface Mount Device
SW	Switch

t_{rr}	Reverse recovery time
USB	Universal Serial Bus
UV	Ultraviolet
V	Voltage
V_{error}	Error Signal Voltage
$V_{feedback}$	Feedback Voltage
V_{FL}	Full-load voltage
V_{in}	Input Voltage
V_p	Peak Voltage
V_{out}	Output Voltage
V_{NL}	No-load Voltage
V_{ramp}	Ramp Voltage
V_{ref}	Reference Voltage
V_{rip}	Ripple Voltage
V_{RRM}	Repetitive Peak Reverse Voltage
ΔV	Voltage drop
ΔV_{out}	Difference value of output voltage
ΔV_{in}	Difference value of input voltage

©This item is protected by original copyright

LIST OF SYMBOLS

A	Current (amperes)
cm	Length (centimeter)
Hz	Frequency (hertz)
Ω	Resistance (ohm)
μF	Capacitance (microfarad)
μH	Inductance (microhenry)
k Ω	Resistance (kiloohm)
kV	Voltage (kilovolts)
kHz	Frequency (kilohertz)
MHz	Frequency (megahertz)
M Ω	Resistance (megaohm)
mA	Current (milliampere)
mm	Width (millimeter)
mV	Voltage (millivolts)
n	Number of stages
W	Power (watts)

©This item is protected by original copyright

Reka Bentuk Voltan Tinggi DC Bekalan Kuasa Rendah Dengan Menggunakan Penukar DC-DC dan Gandaan Voltan Cockcroft-Walton (C-W)

ABSTRAK

Voltan dc tinggi dan penggunaan kuasa yang rendah digunakan dalam penyejukan kriogenik untuk tujuan sistem penyejukan. Untuk mencapai voltan dc yang tinggi, banyak usaha dijalankan untuk menentukan kaedah baru bagi menghasilkan voltan tinggi di mana nilainya lebih tinggi daripada voltan bekalan. Di samping itu, dc voltan tinggi dengan arus beban rendah memberi kesan kepada masyarakat kita dalam industri aplikasi yang digunakan oleh komputer dan peranti elektronik lain. Antara aplikasinya ialah penjanaan plasma, sistem sokongan dc, pengimbas mikroskop elektron (SEM), fotomultiplier tiub (PMT), mikrofon kapasitif, dan ultrasonik transduser dengan kuasa elektrik di perlukan. Di samping itu, bekalan kuasa dc voltan tinggi adalah suatu unsur kritikal yang perlu dilakukan secara konsisten. Pada dasarnya, voltan tinggi dicapai dengan melaksanakan pengubah. Walau bagaimanapun, projek ini mencadangkan membina voltan dc tinggi berdasarkan pengawal penguisan dan gandaan voltan Cockcroft-Walton (C-W) tanpa menggunakan pengubah. Kerja ini bertujuan untuk mencapai keluaran voltan dc tinggi dan arus dc rendah. Dalam litar penggandaan voltan yang berantai, pengubah adalah sebahagian unit yang besar terhadap bekalan kuasa voltan tinggi dan sebahagian besar kerugian dikaitkan dengan reka bentuk terdahulu. Dengan kewujudan pengubah dalam reka bentuk voltan tinggi, ia sukar untuk mengintegrasikan reka bentuk pada cip. Oleh itu, pengubah tidak digunakan dalam pembinaan 1600 V voltan dc yang tinggi dan arus rendah dalam kerja ini dengan itu, ini membolehkan ia dilaksanakan untuk mengintegrasikan bekalan voltan tinggi dengan litar yang berkaitan pada cip tunggal. Satu prototaip bekalan kuasa voltan tinggi dc dibina berdasarkan reka bentuk, simulasi dan pelaksanaan perkakasan di makmal. Dalam projek ini, pertama sekali simulasi telah dilancarkan di mana parameter yang diperlukan telah ditetapkan, dan hasilnya dikumpulkan melalui pemerhatian. Kemudian, untuk perkakasan bagi tujuan percubaan dilaksanakan dalam makmal voltan tinggi. Reka bentuk yang dicadangkan terdiri daripada litar pengawal lebar denyutan (PWM), pengganda voltan, dan isyarat maklum balas. Satu unit input 5 V mencetuskan litar pengawal LT1618 untuk menjana 30 V yang kemudian menghasilkan 100 V dari keluaran LT8331 yang disambungkan kepada litar pemalar kapasitor diod untuk mencapai akhir 1600 V dengan 200 kHz frekuensi isyarat input. Isyarat maklum balas negatif diperlukan untuk menstabilkan voltan keluaran. Dengan pelaksanaan teknik pengganda voltan C-W, keluaran akan meningkat seperti yang diperlukan berbanding voltan isyarat input 5 V dc. Selain itu, bilangan peringkat pengganda voltan dikurangkan. Simulasi LTspice dan hasil eksperimen menunjukkan bahawa cadangan bekalan kuasa dc yang tinggi boleh menghasilkan voltan sebanyak 1548 V dan 1475 V. Beban semasa 0.16 mA diperoleh melalui perintang beban 10 M Ω bagi kedua-dua pendekatan. Nilai kuasa keluaran 0.25 W berdasarkan beban semasa dan beban perintang dikenakan. Peratusan peraturan sebanyak 0.5% dan 0.02% diperolehi berhubung dengan reka bentuk yang dicadangkan untuk mengekalkan voltan keluaran terhadap sebarang variasi pada input. Kecekapan 79.63% dan 80.25% dicapai melalui simulasi dan eksperimen. Oleh itu, reka bentuk yang dicadangkan sesuai untuk modul bekalan kuasa voltan tinggi dan rendah.

Design of DC High Voltage Low Current Power Supply Using DC-DC Converter and Cockcroft-Walton (C-W) Voltage Multiplier

ABSTRACT

A high dc voltage with low power consumption is used in cryogenic cooling for the purpose of cooling system. In order to accomplish the high dc voltage, numerous efforts are carried out to determine a new method of generating high voltage where the value is higher than the supply voltage. In addition, high voltage dc with low load current particularly affects our society in the application industry used by computers and other electronic devices. Among its applications are plasma generation, dc backs up system, Scanning Electron Microscope (SEM), Photomultiplier Tube (PMT), capacitive microphone, and ultrasonic transducer cooling with less electrical power are required. Besides, a high voltage dc power supply is a critical element therefore must perform consistently. Basically, a high voltage is achieved by implementing a transformer. However, this project proposes building a high dc voltage based on the switching regulator and Cockcroft-Walton (C-W) voltage multiplier without using a transformer. The work aims to achieve a high output dc voltage and low dc current. In the cascaded voltage multiplier circuit, the transformer is the bulkiest part of the high voltage dc power supply unit and most of the losses are associated with it in the previous design. With the existence of a transformer in a high voltage design, it is difficult to integrate the design on a chip. Therefore, the transformer is not used in a construction of 1600 V high dc voltage and low current in this work thus, making it feasible to integrate the high voltage supply with other associated circuits on a single chip. A prototype of high dc voltage power supply is constructed based on a design, simulation and implementation of hardware in a laboratory. In this project firstly a simulation has been launched in which the required parameter is established, and results are gathered through an observation. Then, for an experimental purpose hardware is implemented in a high voltage laboratory. The proposed design consists of Pulse Width Modulation (PWM) controller circuit, voltage multiplier, and feedback signal. A single unit of 5 V input triggers LT1618 controller circuit to generate 30 V which then produces 100 V from LT8331 output that is connected to diode-capacitor multiplier circuit to achieve the final 1600 V with 200 kHz input signal frequency. A negative feedback signal is required to stabilize an output voltage. With the implementation of C-W voltage multiplier technique, the output is boosted up as required from the input signal voltage 5 V dc. This design has been proposed due to the excellent line and load regulation percentage for the high voltage power supply performances. Besides, the number of voltage multiplier stages is reduced. The LT spice simulation and experimental results indicate that the proposed high dc power supply can generate the voltage of 1548 V and 1475 V, respectively. A current load of 0.16 mA is obtained with 10 M Ω load resistor for both approaches. An output power value of 0.25 W based on the load current and load resistor is applied. The percentage regulation of 0.5 % and 0.02 % is obtained regarding to the proposed design in order to maintain an output voltage for any variations at input. The efficiency of 79.63% and 80.25% is achieved for the simulation and experiment respectively. Therefore, the proposed design is suitable for high voltage and low current power supply modules.

CHAPTER 1

INTRODUCTION

1.1 Introduction

A high voltage is commonly used in research studies and various levels of industries (Lucas et. al, 2001). High voltage dc power supplies have been widely applied in the field of electrical engineering especially in test equipment such as an electron microscope, x-ray system, insulation test and electronic coating (Bellar et al., 1992; Hwang et al., 2006; Naidu, 1996). Besides, cryogenic cooling is required due to the less of electrical power used. The work presented here is about the design and optimization the performance of the high voltage low current dc power supply modules. This chapter summarizes the main content of the thesis. It covers the background overview of a high voltage power supply. Next, this chapter describes the problem statement of this research. Then, the main research objectives and the scope of the research are discussed in details. Finally, the organization of the thesis is briefly explained.

1.2 Overview of High Voltage DC Power Supply

Nowadays, our society is governed by computers and other electronic appliances. High voltage dc power supply with low load current is the key component in many electronic appliances, which might use photomultipliers tube (PMT), avalanche photodiode (APD), ultrasonic transducer, capacitance microphones, and radiation

detectors. The high voltage dc power supply being a critical component within the appliances must perform consistently and also reliably.

The high voltage dc power supply has unique concerns which differentiate it from a conventional dc power supply requirement. In the high dc voltage, noise must be kept pristinely under a millivolt (mV). Normally, switching regulator configurations cannot achieve this performance level without employing special techniques. Some of the factors that affect the performance are stray capacitance, power loss in insulation and corona as the frequency of the operation is increased. Special techniques are needed in power stages optimized to minimize a high frequency harmonic content to achieve a good performance.

The design of a high voltage dc power supply with low load current requirement is complex and requires suitable components to withstand high voltage in the circuit. In order to achieve maximum performance, special techniques are used by using diodes and capacitors with high voltage rating, low loss and good frequency response to minimize the size. Switching regulator is widely used to get high voltage dc supply. High frequency oscillators are used with a step up transformer by appropriate rectifier and filters. High content of harmonic frequency can be reduced and good performance can be achieved by optimizing power level through the special technique.

Figure 1.1 shows typical building blocks of high voltage dc power supply. The input stage provides rectification and filtering for ac varying from 12 V to 480 V at frequency varying from a few Hz. AC signal from oscillator is fed to a high frequency step up transformer to boost up the output to a reasonable high voltage ac (Bellar et al., 1992). The secondary voltage of the transformer is passed through voltage multiplier consisting of a capacitor and diode. The voltage regulation is achieved by using current or voltage feedback to control the circuit. The transformer is usually the bulkiest part of

the high voltage dc power supply. High voltage power supply is a complex power conversion circuit that converts a lower voltage potential to a higher voltage potential. Therefore, with the advent of portable appliances, it is often desirable to integrate the high voltage power supply too as part of a module to operate with 5 V dc supply. The basic high voltage power supply has been implemented for the purpose of high voltage application.

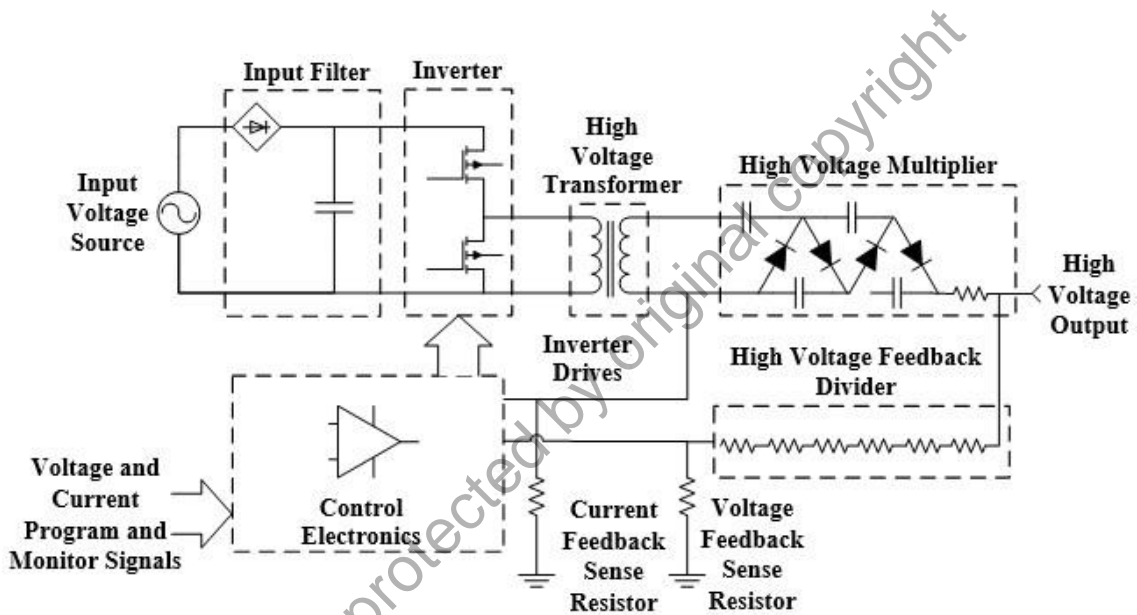

Figure 1.1 : Basic high voltage power supply circuit (Bellar et al., 1992).

In a transformer-less design of high voltage dc power supply to operate with 5 V dc inputs, an oscillator to give a periodic signal is required. The high frequency oscillator output is applied to a series of voltage multiplier circuit to give the desired dc voltage output. The number of capacitors and diodes combination capable of giving the high voltage increases proportionally with the ratio of output to input voltage. Therefore, in order to obtain 1600 V dc voltages from 5 V dc supply, the 320 stages of voltage multiplier is necessitated with capacitor and diode combination. This approach

is used without splitting a suitable voltage multiplier stage and with implementation of step-up converter.

In this research, the design of a transformer-less high dc voltage generated from a 5 V dc input is presented. By using an innovative technique, the number of a capacitor and diode necessary in this design is reduced to less than 40, a decrease in the component count by a factor of 300 with some auxiliary circuits. Thus it reducing the power dissipation, area and component count in this design. The diode in high voltage power supply can be integrated as one chip and the capacitor can be integrated as another chip. When high voltage dc power supply is required, a voltage multiplier circuit consisting of rectifiers and capacitor are used. These circuits are inexpensive, easy to design, versatile and can provide virtually any output voltage that is an odd or even multiple of input voltage.

1.3 Problem Statement

High voltage dc power supply is required with a present of a voltage multiplier circuit that consists of capacitors and diodes connected in series. This combination is used to achieve equivalent voltage increments across each of the series capacitor. The number of stages is declared as a couple of capacitor and diode arrangement. By increasing the number of stages, the output voltage value can be increased. Then, the dc output voltage also decreases as the load current is increased although from a pure circuit standpoint, voltage multiplier is relatively easy to design.

However, the selection of the components is one aspect of the overall design that should not be taken for granted. Careful consideration of all component parameter is the only way to ensure both reliable and predictable circuit performances. The output

voltage value gives an impact that produce the value lesser than theoretical value ((Waghamare & Argelwar, 2015; Zabihi et.al, 2009)). The stage of voltage multiplier design involves the components which influence the deficiency occurred. Most of the high value of voltage drop and ripple voltage are happened in output circuit design due to the maximum number of stages (Katzir & Shmilovitz, 2016; Park, Katzir et.al, 2015). Besides the input signal frequencies needs to considered because it also gives the same effect which influence the performance of output voltage through transient time (Malviya & Bhardwaj, 2016). Most of the design consume transformer but due to the bulkiest parts and leads to voltage spikes, its can damage circuit and produce slow rise time of output voltage (Katzir & Shmilovitz, 2015, 2016).

Therefore, there is a need to find a new design to decrease the number of components with no transformer is used in the construction of the 1600 V dc output with compact size consequently, making it feasible to integrate the high voltage supply with other associated circuit on a single chip. Besides, the capacitor bank cannot be integrated on the chip because the technology to fabricate high voltage capacitor on silicon has not yet matured. The capacitor will be fabricated on another chip to form a capacitor bank.

1.4 Research Objectives

In this research, the main objective is to design and fabricate the high voltage low current circuit by a given design variable. Other than that, several objectives must be achieved. The objectives are listed below: -

- i) To investigate the operation of voltage multiplier and design the diode array for dc high voltage low current power supply module.

- ii) To propose and design a 1600 V dc high voltage low current power supply module.
- iii) To develop and test the prototype of dc high voltage low current for power supply module.

1.5 Research Project Scope

The research starts by studying and understanding the arrangement of rectifier and capacitor in voltage multiplier. This will make them to force equal voltage increments across each of these series capacitors. In order to maximize the high voltage and low current value with minimum total of components, voltage drop and ripple voltage value are the main focuses in this research.

The Cadence tools, Pspice is used to analyze and simulate the voltage multiplier circuit to estimate the number of cascaded components acquired to develop 1600 V dc from 5 V dc supply. To build the power supply design, the selection of the components are applied based on minimum value of voltage drop and ripple voltage. Besides, voltage regulation is introduced with a minimum number of stages.

By optimizing the construction of the high voltage power supply module, LTspice simulation able to improve computation competency with a combination of integrated circuit (IC) and voltage multiplier circuit. The development of printed circuit board (PCB) for this module part is conducted in Eagle environment for the purpose of reducing area on a chip and increasing the reliability of the voltage multiplier.

The laboratory equipments is applied for the purpose of hardware measurement such as power supply and voltage regulator. From the fabricated power supply module, the output voltage is measured by implements a digital multimeter that has been

modified to become high voltage probe. This limitation of this probe is 10 kV for the high voltage measurement. So that, the required voltage still in the range of this measurement tools.

1.6 Thesis Organization

This research thesis is divided into five sections which are Chapter 1- Introduction, Chapter 2-Literature Review, Chapter 3-Methodology, Chapter 4-Results and Discussion, and Chapter 5-Conclusion.

Chapter 1 presents the overview of high voltage power supply, problem statement, research objectives, research scope and the organization of the thesis. Then, Chapter 2 explains previous studies that are related to the research. It covers the operations of the voltage multiplier development and the technique applies. Moreover, it also highlights the parameter which is suitable for this design and the main criterion involves in ensuring the reliability of the circuit performances. The design specification and several approaches are also presented to improve the circuit performance. In Chapter 3 discusses the methodology of the research that covers the most preferred method and procedures used in carrying out the project. Besides that, a brief description on a systematic approach, tools, components and techniques applies in order to achieve research objectives are presented. Chapter 4 illustrates the simulations of the proposed circuit design and the optimization results of high voltage power supplies module by using appropriate software. Hardware work is fabricated and measured to validate with simulation environment. Important findings are presented and the research objectives are reviewed to ensure the goal sets is satisfied. The results achieved are discussed in details. The last Chapter 5 summarizes the main findings and reviews the scope

covered. Suitable recommendations for further improvement in the design of high voltage dc power supply and improvement methods are suggested. The novelty and contribution of this research are also discussed in this section.

©This item is protected by original copyright

CHAPTER 2

LITERATURE REVIEW

2.1 Introduction

This chapter provides an overview of literature studies that is related to the fundamental and concepts of transformer less high voltage power supply by implementing Cockcroft-Walton (C-W) voltage multiplier circuit design. Several criteria and specifications are discussed to meet the high voltage requirement by concerning the weakness of the transformer. Besides, the performances based on a recent high voltage design are also described in this chapter.

2.2 High Voltage Generation

This C-W voltage multiplier is very prevalent among high voltage dc application due to the benefits of low voltage stress on the capacitors and diodes, the circuit compactness and cost efficiency. A conventional design of C-W voltage multiplier is constructed by connecting a capacitor-diode ladder stage where each stage constitutes of two capacitors and diodes (Azmi, et al., 2017; Mariun et al., 2006). Voltage-fed modified C-W topologies applied in (Babaji, 2009; Malviya & Bhardwaj, 2016; Simon & Rasheed, 2016; Waluyo et.al, 2015) are discussed where the usage of high turn ratio transformer which leads to high current, voltage stresses and higher switching losses on the switches as in Figure 2.1.

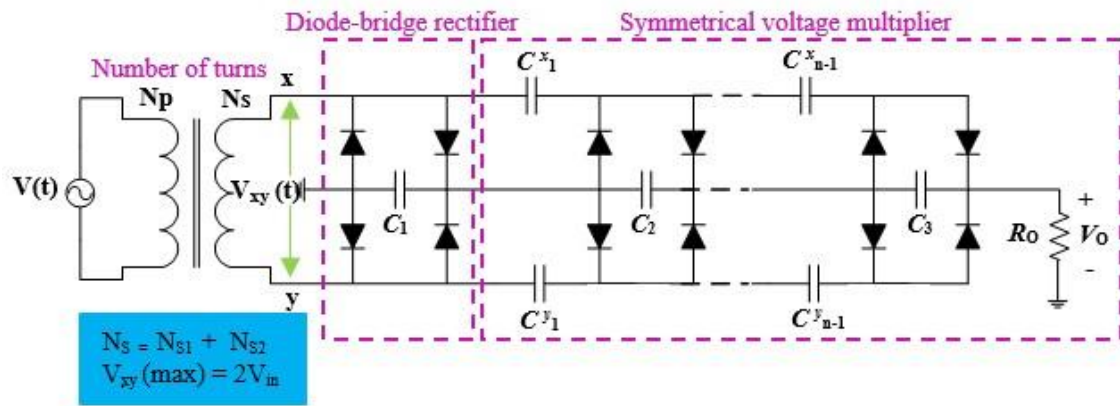

Figure 2.1 : A transformer and voltage multiplier design (Simon & Rasheed, 2016).

Due to several developments of the transformer circuit design, the voltage multiplier has been divided into several sections and splitting sources as proposed in (Sun et al., 2000). As a power loss in a capacitor which is caused by increasing frequency will affect the high voltage dc power supply, it is necessary to retain the produced noise lower than 5% (Wadhwa, 2007). With the implementation of the same values of capacitance, it is believed that the voltage has dropped. Besides, the ripple voltages with noise are increased and the designs, which are presented in (Hwang et al., 2006; Spencer et al., 2001; Tanaka & Yuzurihana, 1988; Young et al., 2014) are the way to improve half-wave C-W voltage multiplier.

In addition, there are other criteria influencing the high voltage management and several methods have been proposed in (Katzir & Shmilovitz, 2016) to achieve the high voltage. However, regarding to the conventional method which covers a multiplier circuit and transformer that utilize the ac source, the transformer will lead to cost inefficiency and the ripple problem will still be unsolved (Barsoum & Stanley, 2015).