



**DEVELOPMENT OF AN IMPROVED
MICROGRID-CENTRALIZE POWER SHARING
SCHEME USING FUZZY LOGIC CONTROLLER**

by

**NURUL NADIAH BINTI AYOP
1530911613**

A thesis submitted in fulfillment of the requirements for the degree of
Master of Science in Electrical System Engineering

**School of Electrical System Engineering
UNIVERSITI MALAYSIA PERLIS**

2017

DEDICATION

To my beloved mom, Rokiah binti Hj. Mohamed, dad, Ayop B. Hj Idris, sister, friends and fiance, those who have not just made this research a successful one, but give a meaning in my life.

This thesis is also dedicate to:-

PM Dr Hamzah (UMP)

Mr. Nor Zaiazmin (UniMAP)

Mr. Zainuddin (UniMAP)

Postgraduate PPKSE

Family PIDA

Housemate

Hisyam

Irwany

Afifah

Wani

ACKNOWLEDGEMENTS

Alhamdulillah, all praise is to Allah for his blessing and strength He gave to complete this master journey. All difficulties throughout the duration of this research were calmly faced and solved with HIS blessing of ideas and solutions. First and foremost, I would like to thanks my beloved parents Mr Ayop and Madam Rokiah for their prayer and support which helped me in completing my research. Lovely thanks to my sibling, Nor Hafizah, Norlaila, Norazlin, Nurul Ain, Nurul Huda and Nor Hayati for their moral support and encouragement that give me the strength to finish my master.

I would like to convey my deepest gratitude to my research supervisor, Dr Mohd Azrik Roslan, for his guidance attention in helping me accomplished this research. His understanding and quality base policy urged me to deliver the best outcome regarding this research. I also would like to thank my co-supervisor, Madam Dr. Syahrul Ashikin who helped me a lot while I was looking for information for my research.

My compliments also go to my friends who indirectly give me a lot of ideas to understand this research until the completion of my thesis. A courteous acknowledgement is made to other members of staff and technicians at PPKSE UniMAP. Their expert guidance regarding my work are highly appreciated. Last but not least, I would like to thanks to KPT for sponsor of scholarship along the research study. Without their presence, none of this is possible to finish my study. For all those whom I might not have mentioned here I sincere apology and thanks everyone who had been a part of my success.

TABLE OF CONTENTS

THESIS DECLARATIONS	i
DEDICATION	ii
ACKNOWLEDGEMENTS	iii
TABLE OF CONTENTS	iv
LIST OF TABLES	vii
LIST OF FIGURES	viii
LIST OF ABBREVIATIONS	x
LIST OF SYMBOLS	xi
ABSTRAK	xiii
ABSTRACT	xiv
CHAPTER 1 INTRODUCTION	
1.1 Introduction	1
1.2 Problem statement	3
1.3 Objective	4
1.4 Scope	4
1.5 Thesis outline	5
CHAPTER 2 LITERATURE REVIEW	
2.1 Introduction	6
2.1.1 Parallel connected inverter system configuration	6
2.1.2 Sinusoidal Pulse Width Modulation	8

2.2	Inverter Control	9
2.2.1	Proportional Integral Controller (PI)	10
2.2.2	Proportional Resonant Controller (PR)	11
2.3	Parallel Connected Inverter Control	13
2.3.1	Droop Control	13
2.3.2	Active Load Sharing	18
2.4	Fuzzy Logic Controller (FLC)	21
2.4.1	General Structure of Fuzzy System	23
2.4.2	Fuzzy Logic Basic Concepts	24
2.4.3	Previous research work performed for FLC system	28
2.5	Summary	33
CHAPTER 3 RESEARCH METHODOLOGY		
3.1	Introduction	34
3.2	Research Flow	34
3.3	Parallel connected inverter for an islanded microgrid	37
3.3.1	Voltage controller of parallel controller	39
3.3.2	Parallel system output voltage	41
3.4	Stability and harmonic impedance analysis of parallel inverter	43
3.4.1	Stability analysis of the voltage control loop	43
3.5	Harmonic impedance	46
3.6	Proposed Power Sharing Technique	47

3.6.1 Central Controller	47
3.6.2 Fuzzy Logic Controller (FLC)	48
3.7 Summary	55
CHAPTER 4 RESULTS & DISCUSSION	
4.1 Introduction	56
4.2 Test I: Proposed power sharing scheme versus conventional droop	57
4.3 Test II: Resistive Load (R Load)	61
4.4 Test III: RL Load	66
4.5 Test IV: Rectifier Load	68
4.6 Test V: Changing Ratio	71
4.7 Summary	73
CHAPTER 5 CONCLUSIONS	
5.1 Conclusion	74
5.2 Research Finding	75
5.3 Future Work	76
REFERENCES	77
APPENDIX A	83
LIST OF PUBLICATIONS	89

LIST OF TABLES

NO.		PAGE
2.1	Comparison between PR and PI controller.	12
2.2	Droop Techniques.	17
2.3	Master slave, Circular chain control, Centralized control, Average current sharing, Average power sharing.	20
2.4	History of Fuzzy Logic Control.	22
2.5	Chronology of research activities FLC.	30
2.6	Fuzzy Logic Controller.	31
3.1	Parameter List.	44
3.2	Membership functions for fuzzy variables.	50
3.3	Fuzzy sets of input power error for magnitude.	51
3.4	Fuzzy sets of input power error for phase.	52
3.5	Fuzzy sets of output power error for magnitude.	52
3.6	Fuzzy sets of output power error for Phase.	53
3.7	Rule Base for Magnitude.	54
3.8	Rule Base for Phase.	54
4.1	System parameter.	56
4.2	System parameters.	62
4.3	List of parameter.	66
4.4	System parameter.	68
4.5	Time during changing.	71

LIST OF FIGURES

NO.		PAGE
1.1	Microgrid in island mode.	2
2.1	The parallel inverter connected in microgrid system.	7
2.2	The current feedback and voltage feedback loop for a single inverter system.	7
2.3	Proportional Integral (PI) controller.	10
2.4	Proportional Resonant (PR) controller.	12
2.5	Fuzzy inference system.	23
2.6	Different types of membership function.	25
2.7	Defuzzification process.	27
3.1	General Methodology of Project.	36
3.2	Microgrid Configuration.	38
3.3	Inverter model with voltage control loop.	39
3.4	The model of the parallel multi inverter system.	41
3.5	Root Locus with different value of K_{Res} .	45
3.6	Root Locus with different value of K_p .	45
3.7	Bode Plot of output impedance (Z) with different value of K_p .	46
3.8	Input and Output of Fuzzy Logic Controller.	49
3.9	(a) Input active of MFs (b) Input reactive of MFs (c) Output phase of MFs (d) Output magnitude of MFs.	49

4.1	Test I simulation results : (a) output current and load current using proposed technique, (b) output current and load current using conventional droop technique, (c) inverters and load P and Q using proposed technique, and (d) inverters and load P and Q using conventional droop technique.	58
4.2	Comparison of transient and settling time for active power (a) Proposed technique (b) Conventional droop technique.	59
4.3	Comparison of transient and settling time for reactive power (a) Proposed technique (b) Conventional droop technique.	60
4.4	Comparison of load voltage amplitude and frequency.	61
4.5	(a) Output current and load current.	62
4.5	(b) Inverter P and Q with load using proposed technique.	63
4.5	(c) Power difference (P_{Δ}) and Phase difference ($\Delta\alpha$).	64
4.5	(d) Figure 1.5: (d) The reactive power difference (Q_{Δ}) and voltage amplitude (E).	65
4.6	Test III simulation results: (a) output current and load current (b) output and load P and Q with load using proposed technique, (c) $P_{\Delta} - \Delta\alpha$. (d) $Q_{\Delta} - E$ Peak.	67
4.7	Test IV simulation results: (a) output current and load current (b) output and load P and Q with load using proposed technique, (c) $P_{\Delta} - \Delta\alpha$. (d) $Q_{\Delta} - E$ Peak.	70
4.8	Test V simulation results: (a) changing ratio (b) output and load P and Q with load using proposed technique, (c) $P_{\Delta} - \Delta\alpha$. (d) $Q_{\Delta} - E$ (Peak).	72

LIST OF ABBREVIATIONS

AC	Alternating Current
DC	Direct Current
IGBT	Insulated Gate Bipolar Transistor
FLC	Fuzzy Logic Controller
MFS	Membership function
PI	Proportional-Integral
PR	Proportional-Resonant
PWM	Pulse Width Modulation
RVG	Reference Voltage Generator
SPWM	Sinusoidal Pulse Width Modulation
UPS	Uninterruptible Power Supplies
VSI	Voltage Sources Inverter
3C	Circular Chain Control
FIS	Fuzzy Inference System

LIST OF SYMBOLS

D	PWM duty cycle
C	Capacitance
C_f	Filter capacitance
f	Frequency
f_{sw}	Switching Frequency
E	Reference voltage amplitude
L_f	Filter inductance
L	Inductance
i_0	Output current
K_p	Proportional gain of voltage controller
K_c	Gain of the current feedback loop
K_{Res}	Resonant gain of voltage controller
M^N	Number of membership function and number of output
N	Number of parallel connected inverters
NB	Negative Big
NS	Negative Small
P	Active Power
P_Δ	Active power difference of jth inverter
PS	Positive Small
PB	Positive Big
PE	Active Error
P^*_j	Active power reference of jth inverter
R	Resistance
R_f	Filter Resistance
R_N	Number of rules
r_{PT}	Active power total ratio
r_{QT}	Reactive power total ratio
r_{Pj}	Active power ratio of jth inverter
r_{Qj}	Reactive power ratio of jth inverter

Q	Reactive Power
QE	Reactive Error
Q_j^*	Reactive power reference of j th inverter
V_{dc}	DC Voltage
v_i^*	Reference Voltage
v_o	Output Voltage
ω_c	Cut off frequency of proportional-resonant controller
ω_o	Rated frequency
X	Reactance
Z_{Line}	Line Impedance
Z_L	Load impedance
δ	Power angle
$\Delta\alpha$	Adjustment angles for the j th inverter
θ	Phase of system impedance

©This item is protected by original copyright

Pembangunan Skim Perkongsian Kuasa Microgrid-Centralize Yang Lebih Baik Menggunakan Pengawal Logik Fuzzy

ABSTRAK

Microgrid adalah grid tenaga tempatan dengan keupayaan kawalan, yang bermaksud ia boleh disambungkan atau diputuskan dari grid tradisional dan beroperasi secara automasi. Baru-baru ini, teknik kawalan droop digunakan untuk menyelesaikan masalah perkongsian beban dalam sistem microgrid. Teknik-teknik ini telah diperbaiki untuk menyelesaikan isu-isu yang semakin meningkat seperti kestabilan sistem dan perkongsian kuasa. Walaupun teknik droop yang bertambah baik menimbulkan kestabilan operasi microgrid, namun prestasi perkongsian kuasa masih tidak dioptimumkan dan boleh dipertingkatkan lagi. Tesis ini memberi tumpuan kepada meningkatkan perkongsian kuasa untuk penyongsang yang bersambung selari dalam sistem microgrid. Dalam kajian ini, satu skim berpusat perkongsian kuasa yang menggunakan Fuzzy logic Controller (FLC) dicadangkan untuk meningkatkan perkongsian kuasa di kalangan penyongsang berhubung selari dalam sistem ac microgrid. Teknik ini dicadangkan dilaksanakan untuk mengawal tiga selari berhubung penyongsang fasa tunggal dalam sistem microgrid. Pengawal berpusat digunakan untuk memproses maklumat keluaran kuasa aktif dan reaktif dari semua penyongsang dan mengira rujukan kuasa keluaran aktif dan reaktif bagi setiap penyongsang berdasarkan nisbah yang dikehendaki kuasa keluaran mereka. Maklumat daripada kawalan berpusat kemudiannya diproses oleh FLC pada setiap penyongsang untuk melaraskan voltan keluaran kepada nilai yang sesuai untuk mencapai perkongsian kuasa yang diperlukan. Beberapa simulasi telah dijalankan untuk mengesahkan prestasi skim perkongsian kuasa yang dicadangkan. Dalam salah satu simulasi, pelaksanaan skim perkongsian kuasa yang dicadangkan dibandingkan dengan teknik konvensional droop. Hasilnya menunjukkan prestasi perkongsian kuasa skim yang dicadangkan mempunyai tindak balas sementara yang lebih cepat dan prestasi keadaan mantap berbanding kawalan droop konvensional. Simulasi lain dijalankan untuk menunjukkan prestasi pengawal dalam mengendalikan jenis beban yang berbeza dan prestasi apabila nisbah kuasa berubah semasa operasi. Simulasi yang dijalankan telah menunjukkan skim perkongsian kuasa yang dicadangkan mampu menghasilkan prestasi perkongsian kuasa yang baik, peraturan voltan yang baik dan mempunyai keupayaan dan kebebasan untuk menetapkan nisbah kuasa bagi setiap penyongsang. Teknik ini meningkatkan tindak balas sementara untuk kuasa aktif oleh 0.175s, (88.37%) dan kuasa reaktif 0.225s, (93.39%) dan peraturan frekuensi sebanyak 1.6%.

Development of An Improved Microgrid-Centralize Power Sharing Scheme using Fuzzy Logic Controller

ABSTRACT

A microgrid is a local energy grid with control capability, which means it can be connected to or disconnected from the traditional grid and operate autonomously. Recently, the droop control techniques are widely used to solve the problem of load sharing in microgrid system. These techniques have been improved to resolve the rising issues such as system stability and power sharing. Although the improved droop techniques improvise the stability of microgrid operations, however the power sharing performance still not optimized and can be further improved. This thesis focuses on improving power sharing for parallel connected inverters in an islanded microgrid. A centralized power sharing scheme that utilizes Fuzzy Logic Controller (FLC) is proposed to improve the power sharing among parallel connected inverters in AC islanded microgrid. This proposed technique is implemented to control three parallel connected single-phase inverters in a microgrid. Central controller is used to process active and reactive output power information from all inverters and calculates the active and reactive output power references for each inverter based on the desired ratios of their output powers. The information from centralized control are then process by the FLC at each inverter to adjust the output voltage to an appropriate value to achieve the required power sharing. Several simulations have been conducted to verify the performance of the proposed power sharing scheme. In one of the simulations, the performance of the proposed power sharing scheme is compared to the conventional droop techniques. The result shows the power sharing performance of the proposed scheme has a faster transient response and steady state performance compared the conventional droop control. Other simulations are conducted to demonstrate the performance of the controller in handling different load types and the performance when the power ratio is changing during operation. The simulations conducted have shown that the proposed power sharing scheme is able to produce good power sharing performance, good voltage regulation and has the ability and freedom to set the power ratio for each inverter. This technique improved the transient response for active power by 0.175s, (88.37%) and reactive power by 0.225s, (93.39%) and frequency regulation by 1.6%.

CHAPTER 1

INTRODUCTION

1.1 Introduction

Nowadays, electrical grid is designed to operate as a structure that consists of generation, transmission, distribution systems and supported with controls and storage devices to maintain reliability, stability and efficiency. In the last few decades, there has been a surge of interest in the technologies of Distributed Generation (DG). DG is defined as an electric power sources connected directly to the distribution network or on the customer side of the network (Ackermann, Andersson, & Söder, 2001). Regarding demand for electricity, DG offers more effective and faster response to solve the problem of reducing the peak demand. Consequently, after the energy crisis and environment issues such as global warming and pollution, the renewable energy resources has attracted research community attention. In globalize era, DG technologies are used in renewable energy industry because they already established. For example fuel cells, bio fuels, wind power and photovoltaic (Pepermans, Driesen, Haeseldonckx, Belmans, & D'haeseleer, 2005). These advance technologies can indirectly reduce stress on grid components by preventing them from operating near their rating and reducing the equipment failure.

In managing huge interconnection of DGs, microgrid concept has been introduced. Microgrid is defined as a system with low voltage electrical network of small modular distributed energy system associated loads that can operates in a grid connected or island mode (B. Kroposki et al., 2008). Fig 1.1 shows the microgrid in island mode. Island mode is the point in the electric circuit where a microgrid is connected to a main grid, but energized by own distributed generation resource. When microgrid is operating

in island mode, amplitude and frequency mostly give effects to control system due to the loss of main network support, which also increases the controlling difficulty of islanding mode operation in a way (Lin, Xu, & Luo, 2013). This standalone microgrid is suitable for supplying power to rural area.

This technology focuses in improving service reliability, better economics, and a reduced dependency on the local utility (Benjamin Kroposki et al., 2008). The main function of microgrid is to ensure the stable system operation during faults and power disturbances (Salam, Mohamed, & Hannan, 2008). This function can give benefit to the environment because it can build energy efficiency and small scale renewable source investment. Furthermore, it provide a good solution to supply power in case of an emergency and power shortage during power interruption in the main grid (Salam et al., 2008).

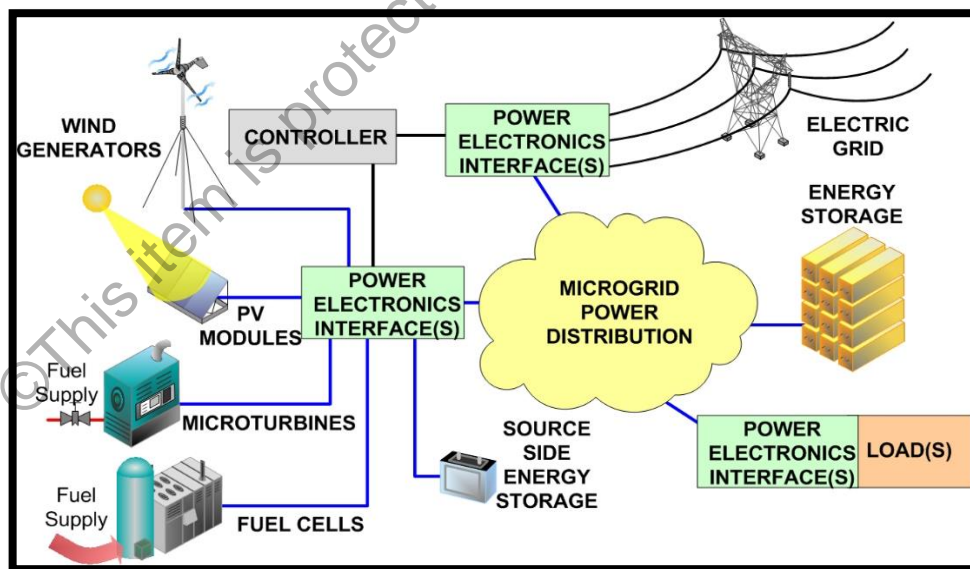

Figure 1.1: Microgrid in island mode (Lin et al., 2013).

1.2 Problem statement

Many forms of DGs such as fuel-cells, photovoltaic and micro-turbines are interfaced to the network through power electronic converters. These interface devices make the sources more flexible in their operation and control as compared to the conventional electrical machines.

In recent years, researchers have shown an increased interest on droop control techniques to solve the problem of load sharing among parallel inverters. This technique has the advantage in term of flexibility because there is no need for communication among parallel connected inverters. However, these techniques suffer from inherent tradeoff between voltage regulation and power sharing (Barklund, Pogaku, Prodanovic, Hernandez-Aramburo, & Green, 2008). In recent years, many researchers have focused to improve the droop control techniques in microgrid system. Although the improved droop techniques give advantage such as stable microgrid operation under several operation conditions, the power sharing performance is still not optimized.

Nowadays, with the advancement in communication system and devices, communication among parallel connected inverters are no longer a big issue. Hence power sharing techniques that utilize communication such as centralized control can be easily implemented. Using a proper communication strategy, better performance and control in microgrid operation can be expected. So it is interesting to explore the possibility of adapting a new power sharing technique in a microgrid control system that achieves better power sharing performance.

1.3 Objective

The objectives of this project are:

- i. To propose a centralized power sharing scheme for parallel connected inverters in microgrid application.
- ii. To design the Fuzzy logic control strategy based power sharing controller.
- iii. To verify the proposed strategy in term of its applicability and settling time transient performance using Matlab/Simulink software.

1.4 Scope

In this research, the main focus is on the inverter control and power sharing control. This research involves simulation of microgrid using Matlab/Simulink software with load variations in each parallel connected inverters. The microgrid is in island mode in which it is not connected to the main ac grid. Three single phase inverters connected in parallel are used in the microgrid. The voltage (amplitude and frequency) and current are supplied by the parallel connected inverters. The DC voltage at the input of inverters is assumed stiff.

1.5 Thesis outline

This report is covered in five chapters. The organization of each chapter is presented as follows:

First chapter generally addresses the problem statements that motivate the essence of this project. Then, project objectives that need to be carried out in completing this project are stated. The scope of this project including the proposed control strategy and its implementation are briefly described in this chapter.

The second chapter presents an extensive literature review associated with the project. It contains research and studies of the theoretical that have been taken from articles, journals or books. It also covers detail literature review of inverter topologies, modulation techniques and control systems for parallel connected inverters.

The third chapter discusses the methodology used in the project. All the steps involved in completing this project have been discussed. Thoroughly it is divided into five sections which are centralized control, parallel connected, voltage stability, harmonics and proposed power sharing methods. The design and technique used are discussed in this section.

The fourth chapter compiles the results that been acquired from the simulation. All relevant data have been presented, analyzed and explained in details.

The fifth chapter is the last chapter that discusses about the overall conclusion for the project. Several recommendations also being suggested in this chapter for improvement of the project in future.

CHAPTER 2

LITERATURE REVIEW

2.1 Introduction

This chapter presents a literature review on the improved microgrid controller using centralized power sharing scheme in island mode operation. Survey of inverter topologies that consists of single-phase and parallel connected inverter are presented and their features are discussed. The modulation techniques used for inverter namely sinusoidal pulse width modulation (SPWM) with bipolar and unipolar switching schemes are discussed. Moreover, controllers such as proportional integral (PI) and proportional resonant (PR) are also explained in detail. The parallel connected inverter control technique is also explained in this section. In addition, Fuzzy Logic Controller (FLC) related literatures are reviewed and discussed.

2.1.1 Parallel connected inverter system configuration

In the previous literatures on microgrid operation, researchers focused only single inverter with single power conditioning system between islanding mode and grid-connected. In general, microgrid can have several advantages when using parallel inverters. The advantages are higher effectiveness, easy expansion and more flexibility as compared to the single inverter system (Cha, Vu, & Kim, 2009). Moreover, if one of parallel inverter failed, it will not effect to the other. The interest on parallel inverter in microgrid's system increases due to its potential benefits to improve service reliability, better economics, and a reduced dependency on the local utility (Benjamin Kroposki et

al., 2008). Fig. 2.1 shows two parallel inverters connected in a microgrid system. The inner current feedback loop and voltage feedback loop can provide good overall performance for both steady state and transient response for a single inverter system as shown in Fig. 2.2.

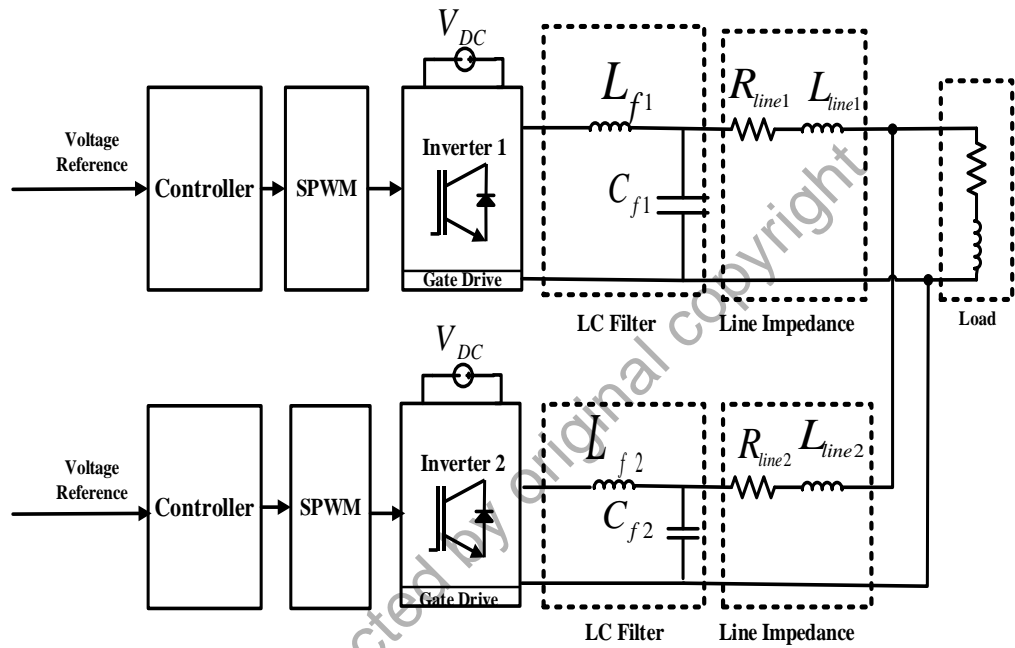

Figure 2.1: The parallel inverter connected in microgrid system.

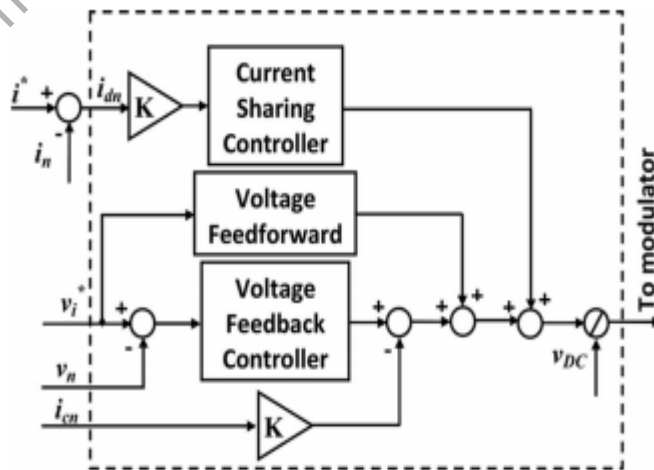

Figure 2.2: The current feedback and voltage feedback loop for a single inverter system (Roslan, Ahmed, Finney, & Williams, 2011).

The author (Guerrero, Matas, de Vicuna, Castilla, & Miret, 2007), proposed a wireless load-sharing controller for parallel connected inverter in microgrid system. This method improves the steady-state and transient response without the use of communication signals. This method also achieves a good dynamic response of the paralleled system. Besides that, in order to achieve an accurate proportional load sharing among parallel connected inverters, mismatch impedance has been proposed by (Zhong, 2013). This process is able to compensate the voltage drop due to the effect of load and droop.

In (De Brabandere et al., 2007), a voltage and droop control method for parallel inverters is presented. The voltage and frequency can be controlled by droop control techniques. This parallel inverters achieves good performance of controller. The author (Vasquez, Guerrero, Savaghebi, Eloy-Garcia, & Teodorescu, 2013), proposed the modelling, control design and stability analysis of parallel connected three-phase VSIs. A hierarchical controller was developed at three levels in parallel system. The system has achieved a good performance during islanded and grid-connected operation.

2.1.2 Sinusoidal Pulse Width Modulation

Sinusoidal pulse width modulation (SPWM) produces multiple numbers of output pulses with different width (Majhi & Bijoyprakash, 2012). The width of pulses are usually varied in term of the proportion of the amplitude of a sine wave. Thus, the gating signal could be generated by comparing a sinusoidal reference wave with a triangular carrier wave. The frequency modulation ratio (m_f) and amplitude modulation ratio (m_a) are shown in equation (2.1) and (2.2):

$$m_f = \frac{f_{carrier}}{f_{reference}} = \frac{f_{tri}}{f_{sine}} \quad (2.1)$$

The value of m_f should be an odd integer to avoid sub-harmonic at output voltage and to eliminate the even harmonics. Besides, m_f also should be a multiple of three for three phase PWM inverter to suppress the odd multiple of three and even harmonics.

The amplitude modulation ratio m_a is defined as the ratio of the amplitudes of the references and carrier signals:

$$m_a = \frac{V_{m,reference}}{V_{m,carrier}} = \frac{V_{m,sine}}{V_{m,tri}} \quad (2.2)$$

If $m_a \leq 1$, the amplitude of the fundamental frequency of the output voltage v_o is linearly proportional to m_a . That is,

$$v_o = m_a V_{dc} \quad (2.3)$$

The amplitude of the fundamental frequency of the PWM output is controlled by m_a . If m_a is greater than 1, the amplitude of the output increases with m_a , but not linearly (Hart, 2011).

2.2 Inverter Control

Inverter with an implementation of suitable modulation technique and control system was widely studied and investigated for its performance in various applications.

Inverter is usually used as interface between the distributed energy resources and the microgrid. These inverters can be controlled by the Proportional -Integral (PI) controller or Proportional Resonant (PR) controller.

2.2.1 Proportional Integral Controller (PI)

PI controller is supposedly designed to improve the performance of the switch of the inverter and integral mode of control is designed to eliminate the steady-state error (offset) inherent in proportional mode control. It can produce optimal performance of the operating conditions in addition to control the duty ratio of the inverter. The combination of proportional and integral term is important either to increase the speed of response or eliminate the steady state error. The integral mode is used along with the proportional control mode in the controller section of a closed-loop system.

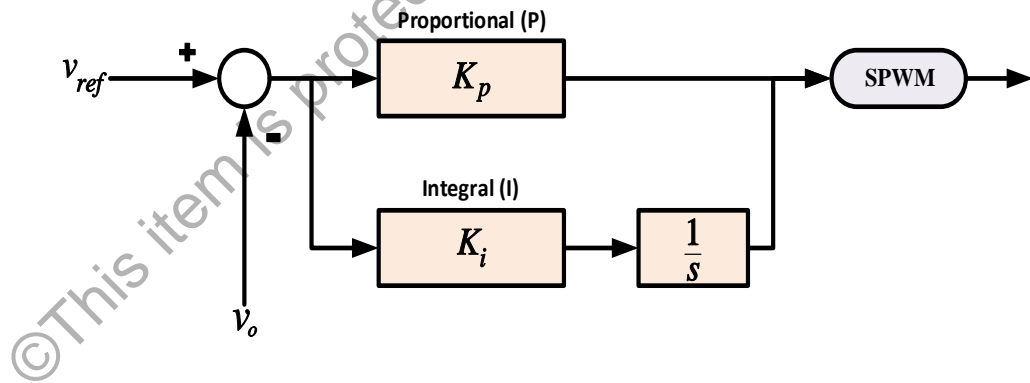

Figure 2.3: Proportional Integral (PI) controller.

Fig. 2.3 shows PI controller block diagram. The PI controller $G_{PI}(s)$ is represented by:

$$G_{PI}(s) = K_p + \frac{K_i}{s} \quad (2.4)$$