



UniMAP

**An Efficient AC-DC Converter with Power Factor
Correction**

056151

rb

FTK7872
C8A154
2015

By

**Mustafa Emhemed Abdulhafith Abofares
(1532221587)**

A dissertation submitted in partial fulfillment of the requirements for the
degree of Master of Science (Electrical System Engineering)

**School of Electrical System Engineering
UNIVERSITI MALAYSIA PERLIS**

2015

ACKNOWLEDGEMENT

I would never have been able to finish my dissertation without the guidance of my committee members, help from friends, and support from my family and wife.

I would like to express my deepest gratitude to my supervisor, Dr. Mahmoud Albream for his excellent guidance, caring, patience, and providing me with an excellent atmosphere for doing research.

I would also like to thank my parents, and elder brother. They were always supporting me and encouraging me with their best wishes.

Finally, I would like to thank my wife. She was always there cheering me up and stood by me through the good times and bad.

TABLE OF CONTENTS

| NO. | PAGE |
|---|------|
| DECLARATION OF THESIS | I |
| ACKNOWLEDGEMENT | II |
| TABLE OF CONTENTS | III |
| LIST OF FIGURES | V |
| LIST OF TABLES | VIII |
| ABSTRAK | X |
| ABSTRACT | XI |
| CHAPTER 1 | 1 |
| INTRODUCTION | 1 |
| 1.1 Background | 2 |
| 1.1.1 Power Factor | 5 |
| 1.2 Problem Statement | 7 |
| 1.3 Research objectives | 8 |
| 1.4 Research questions | 8 |
| 1.5 Scope | 9 |
| 1.6 Thesis Outline | 10 |
| CHAPTER 2 | 11 |
| LITERATURE REVIEW | 11 |
| 2.1 Background | 11 |
| 2.2 Circuit Topology of AC-DC converter | 14 |
| 2.2.1 Uncontrolled AC-DC | 16 |
| 2.2.2 Controlled AC-DC | 18 |

| | |
|---|-----------|
| 2.3 Design of CMOS AC-DC converter | 19 |
| 2.4 Summary | 27 |
| 2.5 Filter | 29 |
| 2.5.1 1st order LC | 30 |
| 2.5.2 2nd order RLC | 31 |
| 2.5.3 Important of filter | 32 |
| 2.5.4 Why PF correction? | 33 |
| 2.5.5 Sources of Harmonic | 34 |
| 2.5.6 Effects of Harmonics | 36 |
| 2.6 Power Factor Correction Techniques | 39 |
| 2.6.1 Passive PFC Technique | 39 |
| 2.6.2 Active Power Factor Correction (APFC) | 41 |
| CHAPTER 3 | 45 |
| RESEARCH METHODOLOGY | 45 |
| 3.1 Introduction | 45 |
| 3.1.1 Rectifiers and Filters | 46 |
| 3.2 Low Power Bridgeless AC-DC Converter | 48 |
| 3.2.1 Analyzing the Power Section when Switches are OFF | 53 |
| 3.2.3 Highlight | 54 |
| 3.3 Proposed Method Based on Power Factor Improvement | 55 |
| 3.4 Deriving the Equations | 57 |
| 3.5 Operation of the Proposed Method | 63 |
| 3.6 Summary | 67 |

| | |
|---|----|
| CHAPTER 4 | 68 |
| RESULTS AND DISCUSSION | 68 |
| 4.1 Output Voltage | 68 |
| 4.2 Checking the System Efficiency | 69 |
| 4.3 Proposed Method Efficiency | 72 |
| 4.3.1 Design Example 1 | 72 |
| 4.3.2 Compute for the System Efficiency | 73 |
| 4.4 Comparison | 77 |
| 4.5 Summary | 80 |
| CHAPTER 5 | 81 |
| CONCLUSION AND FUTURE WORKS | 81 |
| 5.1 Conclusion | 81 |
| 5.2 Future Works | 82 |
| REFERENCES | 83 |

LIST OF FIGURES

| NO. | | PAGE |
|------|---|------|
| 1.1 | Block diagram of power electronic system | 4 |
| 1.2 | Input voltage and current of a bridge rectifier | 7 |
| 1.3 | Converter-based classification of improved power quality converters | 7 |
| 2.1 | Conventional AC-DC circuit using rectifier and filter combination | 12 |
| 2.2 | AC-DC converter topology | 15 |
| 2.3 | Types of Rectifiers | 15 |
| 2.4 | Half Wave Rectifier | 16 |
| 2.5 | Full Wave Center-tapped Rectifier | 17 |
| 2.6 | A Single Phase Full Wave Controlled Rectifier | 19 |
| 2.7 | A Cross-Coupled Active Switch-Only AC-DC converter | 21 |
| 2.8 | System topology and configuration (Wang et al., 2013) | 22 |
| 2.9 | Split-capacitor topology of direct ac-dc converter (Dayal et al., 2011) | 23 |
| 2.10 | Block diagram of the test setup (Dwari & Parsa, 2010) | 24 |
| 2.11 | Block diagram of the active rectifier connected between the harvester and the storage capacitor with ohmic load | 25 |
| 2.12 | Chip AC-DC regulator (Q. Cheng et al., 2014) | 26 |
| 2.13 | Single-input, dual-output AC-DC converter (Jiang et al., 2014) | 27 |
| 2.14 | Passive, first order low-pass RC filter | 30 |
| 2.15 | RLC circuit as a low-pass filter | 31 |
| 2.16 | Passive power factor correction technique | 40 |
| 2.17 | Active power factor correction technique | 41 |
| 3.1 | Flow chart | 45 |
| 3.2 | A full wave bridge rectifier | 46 |

| | | |
|------|--|----|
| 3.3 | A full wave center tap rectifier | 46 |
| 3.4 | Rectified signal of the bridge rectifier | 47 |
| 3.5 | Bridge rectifier with filter capacitor | 47 |
| 3.6 | Filtered output voltage | 48 |
| 3.7 | Proposed low power and low voltage AC-DC converter with ultra-fast diodes across the switching elements | 49 |
| 3.8 | Proposed circuit flowchart | 51 |
| 3.9 | Power section of the proposed low power and low voltage AC-DC converter | 52 |
| 3.10 | Input voltage and current waveform of the proposed method with 50 ohm load | 56 |
| 3.11 | Equivalent circuit when PWM is high | 58 |
| 3.12 | Equivalent circuit when PWM is low | 60 |
| 3.13 | Waveforms | 61 |
| 3.14 | Proposed method with highlighted control loops | 63 |
| 3.15 | Simple way of how the current is sampled for tradeoff between accuracy, efficiency and cost. | 64 |
| 3.16 | Input voltage detection method | 65 |
| 3.17 | Output control loop | 65 |
| 3.18 | All loops are processed by a compensator | 66 |
| 3.19 | PWM Generator | 66 |
| 4.1 | Simulink simulated output voltage of the proposed method for 3V peak-peak input and 2V output with 50 ohm load | 68 |
| 4.2 | Proposed method output voltage at 6peak-peak input and 8.6V output with 50 ohm load | 69 |
| 4.3 | Conventional AC-DC with a boost power factor circuit | 70 |
| 4.4 | Conventional AC-DC flowchart | 71 |
| 4.5 | Forward voltage versus forward current of the diode 20L15T | 72 |
| 4.6 | System efficiency | 76 |

| | | |
|------|--|----|
| 4.7 | Output waveform with an input of 3Vac peak to peak | 77 |
| 4.8 | Input voltage (yellow) and input current (pink) | 78 |
| 4.9 | Output voltage at $V_{in} = 6V_{peak}$ | 78 |
| 4.10 | Input voltage and current at $V_{in} = 6V_{peak}$ | 79 |
| 4.11 | Input voltage and input current waveform | 79 |
| 4.12 | Output voltage waveform | 80 |

©This item is protected by original copyright

LIST OF TABLES

| NO. | | PAGE |
|-----|--|------|
| 2.1 | Chronology of low power AC-DC converters | 38 |
| 2.2 | Voltage distortion limits | 28 |

©This item is protected by original copyright

Yang cekap Penukar AC-DC dengan Pembetulan Power Factor

ABSTRAK

Menyediakan sumber kuasa yang boleh dipercayai dan stabil sentiasa dianggap sebagai penyumbang utama yang boleh memberikan pilihan alternatif untuk menghapuskan kesan-kesan tersebut. Kebanyakan aplikasi penukaran kuasa terdiri daripada peringkat AC ke DC penukaran serta-merta berikutan sumber AC. Output DC diperolehi selepas diperbetulkan kemudiannya digunakan untuk peringkat seterusnya. Oleh itu, AC-DC penukar telah menjadi bahagian penting daripada kebanyakannya semua peralatan elektronik. Penggunaan semasa keputusan penukaran AC-DC dalam menyediakan kualiti kuasa yang berbeza yang juga dicabar oleh kuasa dan voltan pelbagai peringkat yang luas. A bridgeless kuasa yang rendah AC-DC converter dengan faktor kuasa yang wujud pembetulan dan ultrafast diod seluruh elemen pensuisan dicadangkan. A 4-diod penerus jambatan telah digunakan bersama-sama dengan menghapuskan diod tangkapan daripada rangsangan tradisional penukar. Ini manfaat penyelidikan drop diod tunggal penerus separuh gelombang sambil memberi voltan keluaran riak yang sangat rendah oleh penerus gelombang penuh. Hasil penilaian telah dikonfigurasi dengan menetapkan frekuensi pensuisan (FSW) untuk 100kHz ($V_{in_peak} = 6V$; $V_{out} = 8.5V_{dc}$) dengan beban R sama dengan 50Ω yang mengakibatkan kecekapan yang tinggi daripada 95.08%. Faktor kuasa topologi menunjukkan kecekapan terbaik di peringkat V_{in} lebih tinggi daripada 5V puncak yang lebih rendah V_{in} juga. Dengan membandingkan dengan kerja-kerja lain sebelum ini, dapat disimpulkan bahawa kajian sebelum mencapai kecekapan yang terdiri daripada 70- max 95%, yang membawa kepada kesimpulan bahawa litar yang dicadangkan adalah sangat sesuai untuk kuasa yang rendah, voltan rendah aplikasi bukan terpencil.

An Efficient AC-DC Converter with Power Factor Correction

ABSTRACT

Providing a reliable and stable power source is always considered to be the major contributor which can provide alternative option for eliminating such consequences. Most power conversion applications consist of an AC-DC conversion stage immediately following the AC source. The DC output obtained after rectification is subsequently used for further stages. As such, AC-DC converter has become an integral part of mostly all the electronic equipment. Current use of AC-DC conversion results in providing different power quality which also challenged by the vast varying power and voltage levels. A low power bridgeless AC-DC converter with inherent power factor correction and ultrafast diodes across the switching elements is proposed. A 4-diode bridge rectifier was used along with eliminating the catch diode of a traditional boost converter. This research benefits of the single diode drop of a half wave rectifier while giving a very low output ripple voltage by a full wave rectifier. The evaluation result was configured by setting the switching frequency (F_{sw}) to 100kHz ($V_{in_peak} = 6V$; $V_{out} = 8.5V_{dc}$) with R load equal to 50Ω which resulted in high efficiency of 95.08%. The power factor topology showed best efficiency at V_{in} levels of higher than 5V peak with lower V_{in} as well. By comparing it with other previous works, it can be concluded that previous studies achieved efficiency ranging from 70- max 95%, which led to conclude that the proposed circuit is very suitable for low power, low voltage non-isolated applications.

CHAPTER 1

INTRODUCTION

The latest advances in power semiconductor devices led to the utilization of a wide range of power switching circuits such as switch-mode power supplies and others in order to facilitate overall system performance. Because of nonlinear behavior that usually occur in power-switched circuits, distorted currents are usually taken from the line, resulting in low power factor and high total harmonic distortion (THD) (Park, Choi, Cheon, & Rim, 2014; Tsai, Chen, et al., 2013). The process associated with the reduction of power quality in numerous electronic programs is becoming a significant issue as indicated by means of quite few studies. However, in order to boost power factor of the granted electronic systems, it is essential to design and formulate power factor correction (PFC) along with the system. This kind of PFC routine can be an independent unit that consider in contrast to the dc–dc converter. A number of stages can be applied on the converter in order to ensure a sufficient power correction state by the means of using two or multiple PFC. (Singh, Singh, Chandra, & Al-Haddad, 2011). Considering that the voltage of certain power system is normally not really distorted (near sinusoidal), the fundamental notion of PFC mostly consists on designing power circuits along with certain methods in order to enrich power current which later used to follow the actual waveform on the line voltage.

In addition, the AC-DC converters, also called rectifiers, are created with the use of thyristors and diodes to deliver both uncontrolled and controlled DC electric current with both bidirectional and unidirectional flow of electric power. They hold the

demerits involving poor electric power quality when it comes to inject present harmonics, induced voltage distortion and poor electric power factor which consists of the AC and slow various rippled DC at weight end (Athab, Lu, & Ramar, 2012). Furthermore, the design of AC-DC in most power systems may result in different levels of efficiency. In light of these increased applications, a new strain of rectifiers continues to be developed making use of new solid state with self-customized circuit such as MOSFETs and gate turn-off thyristors (GTO), even a number of which include either not necessarily been considered or difficult to always be developed previously using diodes and thyristors. Such tools are called converters, and specifically referred to as switch-mode rectifiers (SMRs) and power-factor correctors (PFCs). Because involving strict dependence can impact power quality with the current settings of AC (Narimani & Moschopoulos, 2013).

Even in some cases the power efficiency of converter embedded in different active filters is nearly close to the one from the load. Therefore, this study can provide an alternative way for embedding power in converter by inheriting part of the system in AC-DC conversion. This is necessary to provide reduce voltage, higher proficiency, and well controlled and also regulated DC for the aim of generating flexible operation from the system.

1.1 Background

The categorization of power converters was heavily studied by previous studies in terms of AC-DC converters, AC-AC, DC-AC and DC-DC converters. There are several different versions of the converters topologies, with regards to the allocation of

semiconductor as well as components with passive capacitors, inductors and transformers (Weise, Castelino, Basu, & Mohan, 2014). Mostly, the applications of power conversion comprises an AC-DC conversion phase directly following the AC source. And the DC output got after modification is used subsequently in next stages. As such, AC-DC converter has become an integral part of mostly all the electronic equipment. Mainly, this type of application is used as an interface between most power electronic equipment and the utility.

It has been acknowledged that the total power being expended by an electrical system is mostly decided by the power factor (PF) of power system. The customization of single stage AC-DC can be achieved by utilizing the bidirectional conduction capability of integrated circuits low resistor (MOSFETs). The conceptualization of AC-DC converter is recognized as a fostering mechanism to be placed along with other converters. However, AC-DC converters are still facing a number of challenges with it comes to regulating its performance when using power factor correction (PFC). PFC is commonly used to customize the current in order sinusoidal the input voltage in a certain time. The application of PFC is recognized as the most sufficient power supplies to which it provides the suitable configurations to fits certain power system. This include providing the suitable setup of harmonic content that linked to the input line current. With this in mind, AC-DC converters are commonly began utilized in different domains.

Figure 1.1 presents the main characteristics of standard power electronic system, where the power source is begun, projected into the power converter in a single phase or three-phases. The generated load from such source can be processed from undesired power source. This is usually take place when power source is initiated on line frequency ranged from 60Hz or 50Hz. The processed load source then is references to

be fed to the controller. The load voltage is usually managed by the controller in which the obtained information from the power source is compared to the reference signal generated from the load. Such load is resulted from the power converter (Singh et al., 2011).

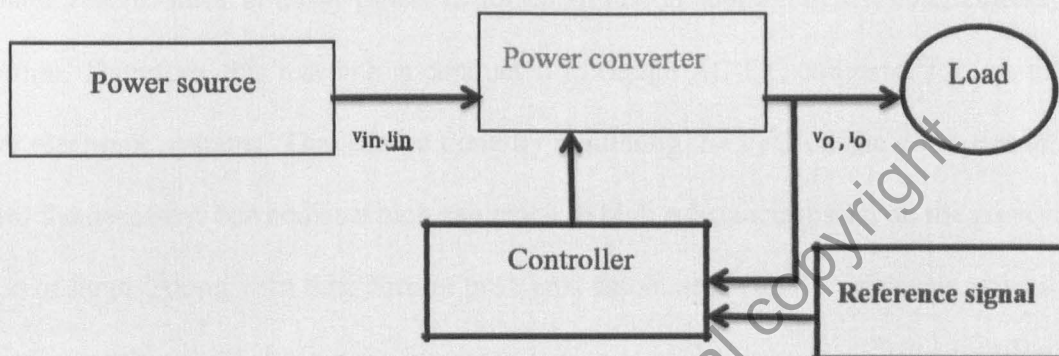

Figure 1.1: Block diagram of power electronic system

Moreover, the current requirement regarding DC strength could be supplementary, for example feasible to use in electric regulates, or maybe vital, such as DC link of motor. At the same time, regulating companies are enforcing rigid harmonics. This can be reasoned to the actual high strength issue as well as low line existing harmonic distortion demands (Mrozek, 2013). Beyond the ongoing power issues, high efficiency power converters are always on demand. In order to regulate the frequency rate of AC-DC converters, it is essential to utilize a line diode bridge rectifier in order to be constant with the filter capacitor that usually applied along with the rectifier. This is necessary to provide the require wave in the output voltage.

However, the current strained resulted from such converter is usually results in peaky flow especially in the case of using large capacitor. This is because of that associated AC usually consist of low voltage which typically result in harmonics and the presence of these type of harmonics leads to the complete distortion of harmonic

system that can be very high and deprived input power factor deprived. The problems associated with such harmonics and minimal power elements, harmonic specifications and guidelines are certainly enforced by the utilities that results in limiting the quantity of distorted current allowed into the utility (Mahmood et al., 2013). It is highly required to obtain a rectification at utility power factor all around in addition to low enter current distortion. Therefore, this research is conducted to design AC-DC converter for use in power electronic systems. This can be done by regulating the PFC on the converter to control the necessary harmonics which can reach to high substances based on the power source of input. Along with this, current problems associated with the irrelevant power harmonics could positively impose harmonic values to which it may result in limiting the amount of allowed distortion of current in the utility (Singh et al., 2011). Therefore, it is recommended to attain a certain level of rectification all-around utility power as recommended by Chen, Soong, Pathmanathan and Ertugrul (2012).

1.1.1 Power Factor

AC to DC conversion will not just end by simply employing rectifiers and filters. The system power factor must be considered as well. Rectifier-filter combination gives low power factor. What is the effect of having a bad power factor though? A bad power factor will give the worst current shape in the line. The current peak and RMS value are high. Although it has no effect on the consumption of a specific load or appliance, its effect in the transmission line is huge. Consider the fundamental equation for real power in Eq. 3.1 (Erickson & Maksimovic, 2007).

$$P_{REAL} = V \times I \times \cos\theta = V \times I \times PF \quad (1.1)$$

Appliances will draw real power and fixed. For instance, a subwoofer system, the rated power is 100W. This is the fixed power drawn by the appliance from the wall

outlet. The domestic line voltage V per country is fixed as well. Therefore, in Eq. 3.2 the variables are current I and power factor PF (Erickson & Maksimovic, 2007). Let us re-write the equation as below.

$$I = \frac{P_{REAL}}{V \times PF} \quad (1.2)$$

From Eq.3.2, when the power factor is poor (an ideal value and the best power factor is unity), the current is going to be high. This current travels into the transmission lines. This high current causes a high voltage drop on the line and heating on the transmission cables will occur. The electric utility may repair their transmission facility too often and the transmission loss is high. In many countries (e.g., Germany, Australia, US, etc.), the transmission loss or generation loss will be charged on top to the individual consumer's actual energy consumptions.

Another adverse effect of having a poor power factor is disturbance to the other system connected to the same wall outlet or AC receptacle. A system with a bad power factor will have much harmonic content on its current.

Power factor correction circuit is can be a passive or an active configuration. A passive approach is using passive devices only to correct the phase difference between voltage and current as well as remove the harmonic content of the current. It is not very effective in improving power factor for non-linear systems. The best example of a non-linear system is the rectifier-filter combination.

On the other hand, active power factor correction circuit is utilizing active devices and circuit to force the voltage and current in-phase to each other and removes the

harmonic content of the current. This is widely used approach in switching converters and power supply.

Fig 1.2 is shows the input voltage and current of the circuit 3.8. The current is only started to flow through the diodes when the level of the input voltage is near its peak. This is very undesirable and needs to be corrected.

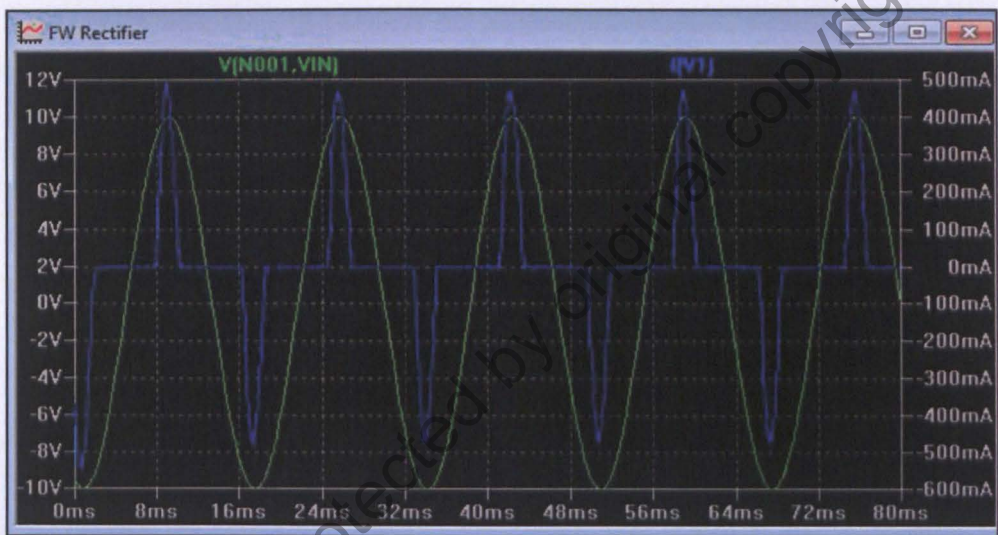

Figure 1.2: Input voltage and current of a bridge rectifier

1.2 Problem Statement

In power electronics systems, a constant regulated voltage of DC output is necessary for sustaining power flow. This include Switched-Mode Power Supplies (SMPSs), low-rating Automated Switching Devices (ASDs) in air conditioners, fans, etc., to which some other applications may requires additional DC voltage. Such voltage can be provided from traditional semi-converter and is completely controlled thyristor converter having both bidirectional and unidirectional flows of power (Balestero, Tofoli,

Fernandes, Torrico-Bascopé, & De Seixas, 2012; Cho, Kwon, & Kwon, 2014). With the consideration of power efficiency of AC-DC converter system and power factor corrections in many single-phase AC-DC converter circuits, it is important to reduce harmonic distortion, hence increase power efficiency of electric appliances. With this in mind, the researcher aims at determining the potential of low power bridgeless AC-DC with inherent PFC.

1.3 Research objectives

The key objectives of this research include:

- 1) Design a low power bridgeless AC-DC converter with inherent power factor correction.
- 2) Improve the power efficiency for power electronics system with ultralow diode voltage drop.
- 3) Evaluate the proposed design based power factor correction for power electronics system.

1.4 Research questions

This research aims at answering the following questions:

- 1) How to provide an efficient AC-DC for power electronic systems?
- 2) How to enhance the power efficiency for power electronics system?

3) What is the efficiency of possible design based on PFC for power electronics system?

1.5 Scope

Figure 1.3 shows the categorization for improved power quality converters. This research focuses on designing an efficient AC-DC converter for power electronic systems. A bridgeless topology with an inherent PFC circuit is proposed in which removing bridge rectifier the system efficiency will greatly improve. Ultralow diode voltage drop is considered in order to enable the system to operate to lower voltages. The rectification can be set to half wave or a full wave circuit with capacitor filter is added across the load resistance. MATLAB based Simulink was used to design and test the efficiency of the proposed bridgeless topology in this study. The design in this study emphasize on the simulation part only. Future work can consider utilizing the simulation result into experimental phase.

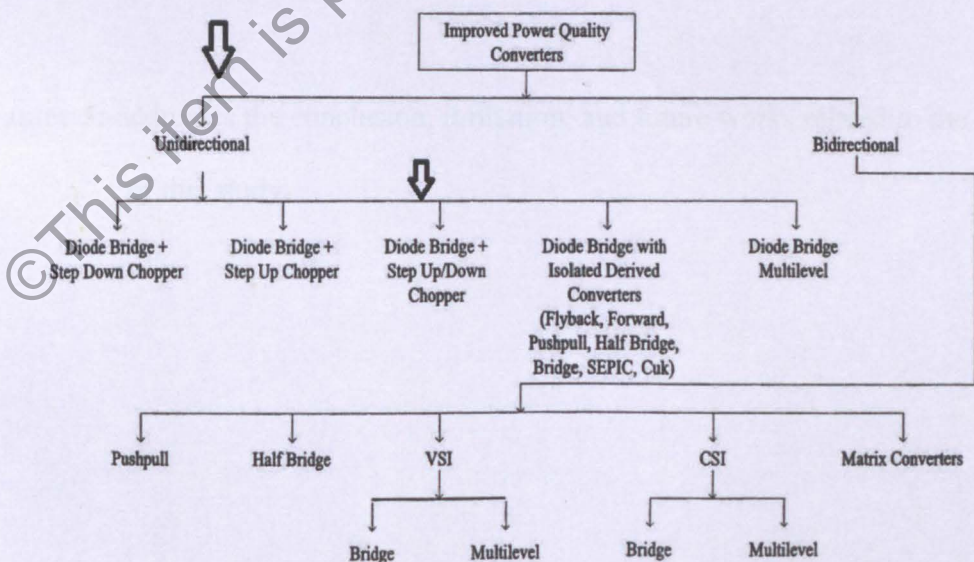

Figure 1.3: Converter-based classification of improved power quality converters

1.6 Thesis Outline

This research is achieved in the following order:

Chapter 1: presents the motivation for conducting this study. It also introduces the research objectives and scope to the application of AC-DC converter with power factor correction.

Chapter 2: covers the literature on power factor corrections in different domains. The main study elements are described and supported by previous studies.

Chapter 3: illustrate the method and procedure used to conduct the analysis of this study.

Chapter 4: highlights the results of the MATLAB simulation along with the efficiency measures.

Chapter 5: addresses the conclusion, limitation, and future works related to the context of this study.

CHAPTER 2

LITERATURE REVIEW

This chapter introduces the main concept of electronic power in line with the present study objectives. The power converters, controllers, and harmonic aspects are covered along with the previous studies with emphasis on AC-DC converter.

2.1 Background

The current demand for providing efficient electronic power converter was the main reason for conducting this study. With not many exceptions, distribution of electric power is throughout AC in various power applications. The use of the AC/DC converters is very high in applications like offline battery, telecom, etc. With the particular advancement involving technology, the AC-DC converters are generally viewed as a sufficient alternative in common power applications (Kong, Jiang, & Lee, 2012). Based on this, AC-DC converter has formed an energetic area involving research throughout recent years (Su, Pan, Long, Sun, & Yang, 2014). While, the extensive use of DC power among different scholar can be supplementary, including use throughout electronic controls, or vital, which result in better DC link performance.

The current needs associated with providing sustainable power regulators are mainly concern on enforcing strict harmonics regulations including International Electro technical Commission (IEC) 500-1000 and so forth (Abdollahi, 2012). This can be reasoned to that the substantial power issue and small line present harmonic

distortion specifications (Pahlevani, Pan, Eren, Bakhshai, & Jain, 2014). In addition to the aforementioned power factor requirements, the benefits of high consistency switching are also being applied to realize the AC-DC converter. The benefits can involve obtaining a high performance, smaller reactive elements, easier selection, and reduced quantity (Athab et al., 2012). To help convert range frequency any AC-DC, a range frequency diode connect rectifier is usually utilized for such purposes.

Meanwhile, at the particular rectifier output, a customized filter capacitor is also used to relieve the ripple produced in output voltage. But present drawn by simply this converter can be peaky throughout nature for the large capacitor (Arias, Vázquez, & Sebastián, 2012).

Within modern systems, there are a lot of the conversions usually performed together with the devices of semiconductor switching, for example, thyristor and diodes in addition to transistors. An AC/DC converter is most widely used and popular power gadget found in the family of gadgets devices. Power gadgets devices are usually characterized being the short routine or a great open routine (Arias et al., 2013). As the actual switching capability, along with efficiency in addition to performance producing power electronics is a fast growing region in electric powered engineering. As well it can be desirable as a result of relatively smaller power loss inside the device (Zito, Lampasi, Maffia, & Candela, 2014). The integrated circuits are enabled by the AC/DC converter to function from some sort of 50/60 Hz alternating current line of voltage through conversion of the actual AC signal into DC signal from the appropriate voltage (Cho et al., 2014).

A power factor can be defined as a phase angle difference between the current and the voltage or the ratio taken between the real power and the apparent power as equation 2.1 below.

$$PF = \cos\theta = \frac{P_{\text{REAL}}}{P_{\text{APPARENT}}} \quad (2.1)$$

That is for a linear system; a system that does not involve rectifier-filter combination. For non-linear systems, the shape of the current must also be considered.

On the other hand, a non-linear circuit input voltage and current shape. The circuit has a rectifier and filter. It is not concern more on the phase angle difference than the distorted shape of the current. Actually for non-linear systems like rectifier-filter combination, the power factor is dictated more with the shape of the current.

Thus, in order to conclude that a system has a good power factor, the phase relationship of the voltage and current must be considered. The current shape must be taken into account as well. Harmonics in the current is a great contributor of a poor power factor.