

PAPER • OPEN ACCESS

## Simulation of multiple pulse width modulation (MPWM) transformerless photovoltaic inverter (TPVI) system

To cite this article: M Masri *et al* 2020 *J. Phys.: Conf. Ser.* **1432** 012017

View the [article online](#) for updates and enhancements.

You may also like

- [Microgap thermophotovoltaic systems with low emission temperature and high electric output](#)  
M S Mirmoosa, M Omelyanovich and C R Simovski
- [Multimillijoule terahertz radiation from laser interactions with microplasma waveguides](#)  
Ke Hu, Longqing Yi and Tünde Fülöp
- [Predicting thermoelectric performance of AlGaSbAs-based systems for thermo-photovoltaic cell applications](#)  
Boualem Merabet, Md Abdul Maleque, Sofyane Belhachi *et al.*



The Electrochemical Society  
Advancing solid state & electrochemical science & technology



249th  
ECS Meeting  
May 24-28, 2026  
Seattle, WA, US  
Washington State  
Convention Center

# Spotlight Your Science

**Submission deadline:  
December 5, 2025**

**SUBMIT YOUR ABSTRACT**

# Simulation of multiple pulse width modulation (MPWM) transformerless photovoltaic inverter (TPVI) system

Masri M<sup>1</sup>, Irwanto M<sup>1,2</sup>, Alam H<sup>1</sup>, Mashor Y M<sup>3</sup>

<sup>1</sup>Department of Electrical Engineering, Institut Teknologi Medan (ITM), Medan, Indonesia

<sup>2</sup>Fellow of Centre of Excellence for Renewable Energy, School of Electrical System Engineering, Universiti Malaysia Perlis (UniMAP), Perlis, Malaysia

<sup>3</sup>School of Mechatronic Engineering, Universiti Malaysia Perlis, Pauh Putra Campus, Malaysia

**Abstract:** Pulse width modulation technique is always applied in the design of inverter. The output voltage waveform of inverter is not relative pure sinusoidal, especially if it is applied linear pulse width modulation. A non-pure sinusoidal voltage waveform can affect the life time of inverter and also the alternating current (AC) loads. The inverter always also uses a transformer that can increase the losses and reduce the efficiency. A technique of multiple pulse width modulation (MPWM) is suitable to be applied in the transformerless photovoltaic inverter (TPVI) system. It can generate pure sinusoidal voltage waveform and increase the performance of inverter. This paper presents a simulation of MPWM TPVI system using SIMULINK MATLAB. It consists of pulse driver circuit to drive four MOSFETs in the full bridge inverter circuit with the output voltage waveform still multiple pulse wave and it is converted to be pure sinusoidal voltage waveform by applying a LC filter circuit.

## 1. Introduction

The renewable energy potentials as technical potential is studied by [1], it is a number of energy exploited using existing technology in a same time and place. From the obtained energy data is evaluated to decide that the energy can be applied for renewable energy power plant or not. Potential of solar irradiation can be applied in to photovoltaic powered uninterrupted power supply (UPS) system using switching controller and inverter that converter DC (direct current) electrical energy to be AC (alternating current). [2] stated that three level inverter is the most popular used in the renewable energy system for its low switching loss compared to the square wave inverter. However, it suffers from problems of high conduction losses. The switching frequency is significantly limited due to the high switching losses caused by the high voltage rated power devices.

There are various techniques to vary the inverter gain. The most efficient method of controlling the gain and output voltage is to integrate pulse width modulation (PWM) control within the inverters. There are five basic PWM techniques as stated by [3]: linear modulation, saw tooth PWM, single pulse width modulation, multiple pulse width modulation and sinusoidal pulse width modulation. Generally, the all inverter uses a transformer to increase the alternating (AC) voltage magnitude. It causes its size, losses and efficiency to be relative big, high and low, respectively. [4] – [9] stated that for reducing the size, weight and manufacturing cost, the transformerless PV inverter is suitable, it improves the efficiency system.

This paper presents a simulation modelling of MPWM TPVI system using SIMULINK MATLAB that consists of pulse driver circuit to drive four MOSFETs in the full bridge inverter circuit and the circuit pf LC filter. A resistive load of 2979  $\Omega$  is applied to the MPWM TPVI system and observed its performance.

## 2. Methodology

This section presents a simulation of the MPWMTPVI system which consists of photovoltaic (PV) module, a pulse driver circuit, a full bridge inverter circuit, and a circuit of LC filter. The simulation procedure explanation of each circuit as stated in this section.

A simulation modelling of 91.8 V, 60 W Kaneka G-SA060 amorphous silicon (a-Si) PV module is important to be created firstly before the overall MPWM TPVI system is simulated. The simulation is based on the data sheet of PV module. It is as a DC voltage source which the level of open circuit voltage, short circuit current and power depend on the solar irradiance and temperature applied in the modelling.

A complete simulation modelling of MPWM TPVI system is shown in Figure 1. The modelling consists of PV module, pulse driver, inverter circuit, LC filter and AC load. The creation procedure of block set of MPWM TPVI system is stated below:

- Create a block set of PV module following Simulation modelling of Kaneka G-SA060 amorphous silicon (a-Si) PV module.
- Create a block set of pulse driver for gating the four MOSFETs in inverter circuit. The carrier frequency in source block parameter of pulse driver. It is 16000 Hz with PWM period of 62.5  $\mu$ s.
- Create a block set of LC filter with cut off frequency in the function block parameter is AC frequency system of 50 Hz.
- Apply measured resistance of 2979  $\Omega$  as AC resistive load. It is measurement result of MPWM TPVI hardware system on 23<sup>rd</sup> April 2015 for 15 W resistive lamp load.
- Simulate the performance of MPWM TPVI system following the measured solar irradiance and temperature on 23<sup>rd</sup> April 2015.

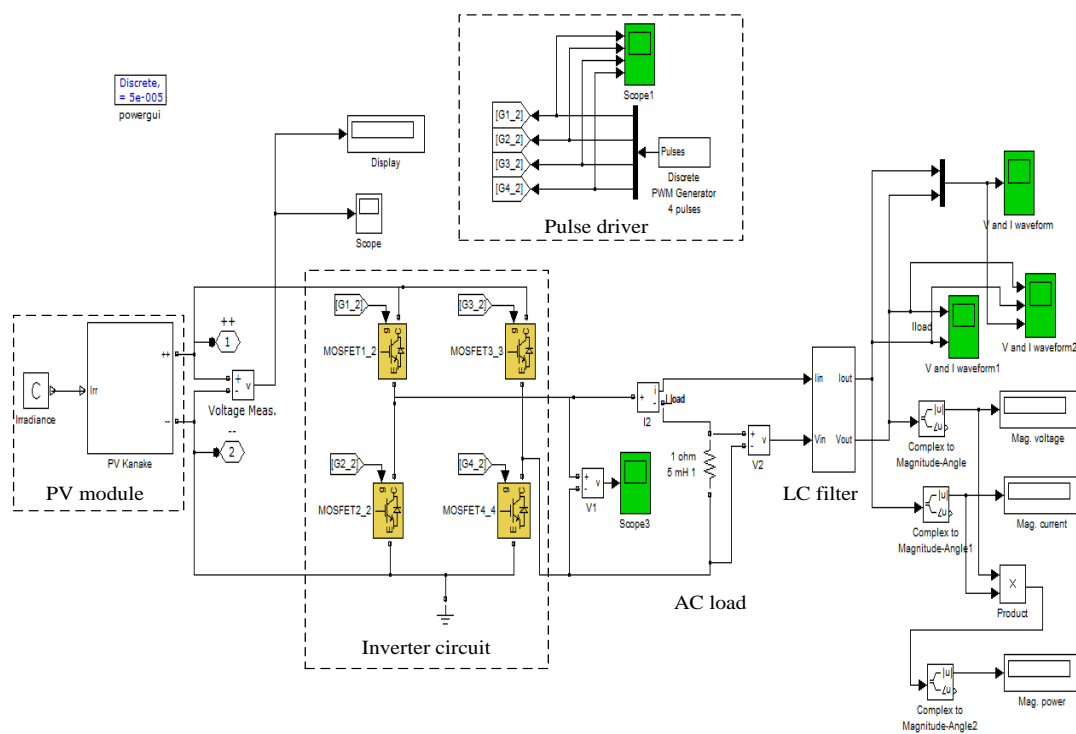


Figure 1. Complete simulation modelling of MPWM TPVI system

### 3. Result and Discussion

The PV module modelling is simulated and validated based on the data sheet of Kaneka G-SA060 amorphous silicon (a-Si) PV module as shown in Table 1. The implementation of PV module in the MPWM TPVI system needs three PV modules connected together in series. It is due to the voltage level system around 240 V is required in the MPWM TPVI system. For this reason, one PV module and three PV modules connected in series are very important to be validated before implementing in the MPWM TPVI system. The comparison of data sheet and simulation result for the performance of Kaneka G-SA060 amorphous silicon (a-Si) PV module is shown in Table 1. The performance of PV module compared are the open circuit voltage,  $V_{oc}$  and short circuit current,  $I_{sc}$ . They are found for the condition of constant temperature of 25°C and varied solar irradiance as listed in Table 1. It is created based on the values of PV performance as listed in the data sheet.

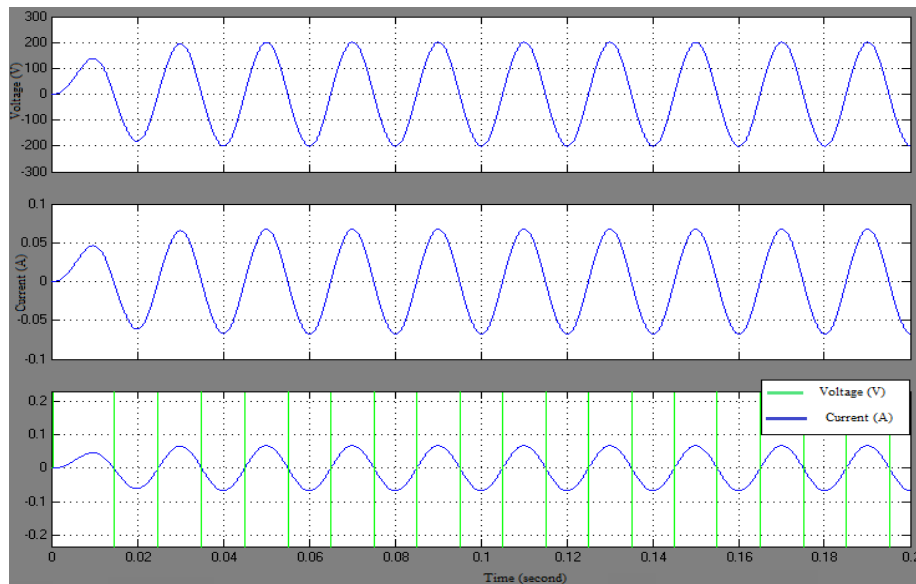
Every value of simulated PV performance as shown in Table 1 is adjusted for the suitable resistance value to produce the required PV performance. The increasing of solar irradiance requires the increasing of resistance value for the required PV performance. The resistance value gives significant effect on the open circuit voltage especially compares the short circuit current. The resistance value increases, thus the open circuit voltage will increase also for the constant solar irradiance and temperature. It indicates that the simulation is acceptable to be implemented to the MPWM TPVI system.

**Table 1.** Performance of Kaneka G-SA060 amorphous silicon (a-Si) PV module based on the data sheet and simulation result

Solar irradiance (W/m <sup>2</sup> )	Resistance (Ω)	Data sheet				Simulation			
		1 PV module		3 PV modules in series		1 PV module		3 PV modules in series	
		$V_{oc}$ (V)	$I_{sc}$ (A)	$V_{oc}$ (V)	$I_{sc}$ (A)	$V_{oc}$ (V)	$I_{sc}$ (A)	$V_{oc}$ (V)	$I_{sc}$ (A)
1000	232	91.8	1.19	275.4	1.19	92.0	1.19	276.1	1.19
900	249	88.7	1.07	266.1	1.07	88.9	1.07	266.7	1.07
800	270	85.6	0.95	256.8	0.95	85.7	0.95	257.0	0.95
700	297	82.5	0.83	247.5	0.83	82.5	0.83	247.4	0.83
600	234	79.4	0.71	238.2	0.71	79.5	0.71	238.5	0.71
500	384	76.3	0.60	228.9	0.60	76.2	0.60	228.5	0.60
400	461	73.2	0.48	219.6	0.48	73.1	0.48	219.4	0.48
300	589	70.0	0.36	210.0	0.36	70.1	0.36	210.3	0.36
200	845	67.0	0.24	201.0	0.24	67.0	0.24	201.1	0.24

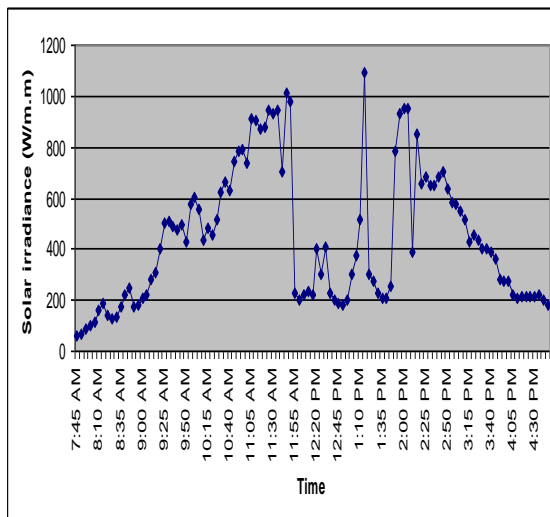
Note:  $V_{oc}$  = open circuit voltage ;  $I_{sc}$ = short circuit current

The AC voltage and current of the MPWM TPVI system for resistive lamp of 2979 Ω, solar irradiance of 456 W/m<sup>2</sup> and temperature of 32.1°C on 23<sup>rd</sup> April 2017 is applied in the simulation. The solar irradiance and temperature are applied as input data of PV module in the simulation of MPWM TPVI system and the resistance value is as resistive load. The simulation result of AC voltage and current of the MPWM TPVI system for the resistive load of 2979 Ω is shown in Figure 2. The voltage and current waveform are in phase. It is due to the type of AC load is resistive load.

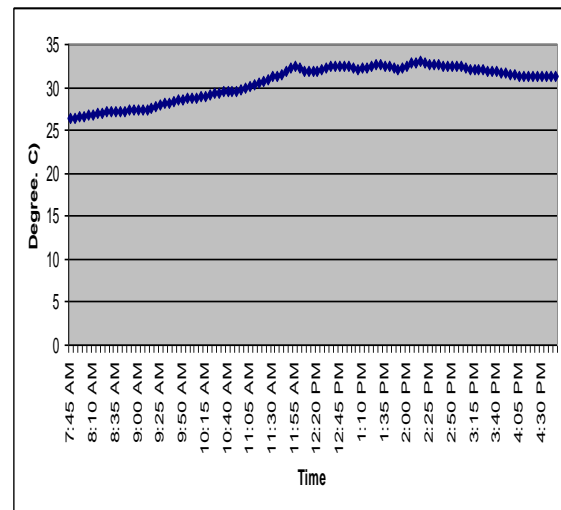


**Figure 2.** Voltage and current waveform of MPWM TPVI system for resistive lamp of 2979  $\Omega$

The condition of solar irradiance and temperature on 23<sup>rd</sup> April 2015 throughout 7.45 am to 4.30 pm as shown in Figure 3 are applied in the simulation, exactly as input of PV modules in Figure 1. The solar irradiance and temperature affect the performance of MPWM TPVI system. The performance observed are AC load voltage and power as shown in Figure 4. It can be seen that if the solar irradiance increase, thus the performance of MPWM TPVI system is also increase, inversely if the solar irradiance decrease, thus the performance of MPWM TPVI system is also decrease.

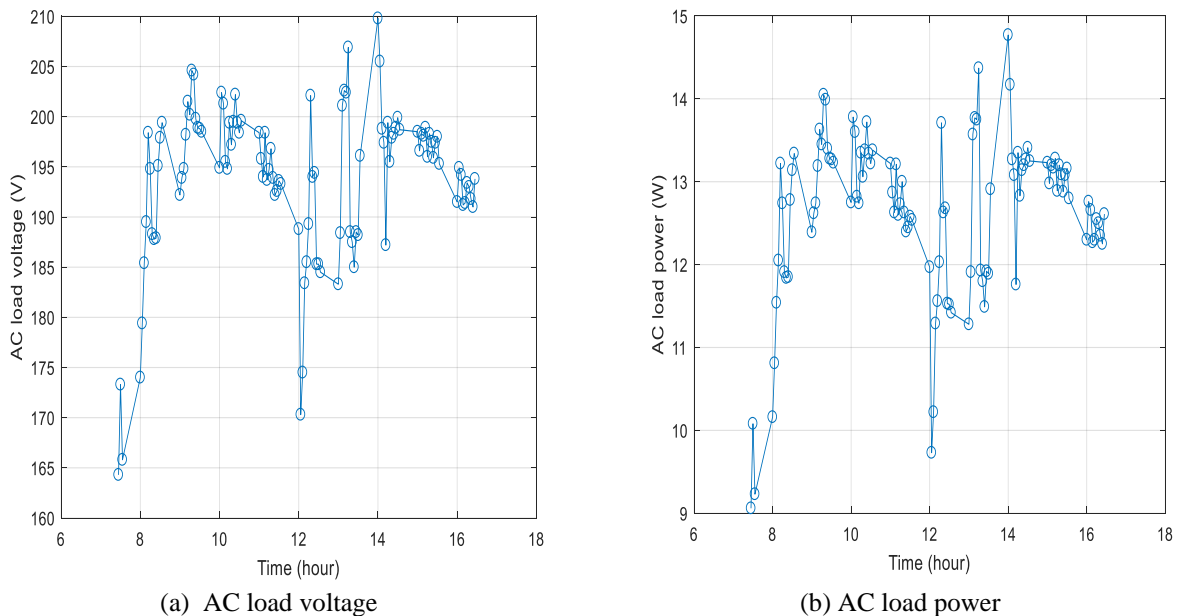


(a) Solar irradiance



(b) Temperature

**Figure 3.** Weather condition on 23<sup>rd</sup> April 2015



**Figure 4.** Performance of MPWM TPVI system

#### 4. Conclusion

The simulation modelling of MPWM TPVI system has been constructed using SIMULINK MATLAB. It is operated directly by PV module. Some conclusions can be conducted as stated below.

The performance simulation of PV module which is as main DC source of MPWM TPVI system is validated by the data sheet of PV module. It indicates that simulation modelling of PV module is acceptable.

The operation of MPWM TPVI system depends on the solar irradiance and temperature. If the solar irradiance increase, thus the performance of MPWM TPVI system is also increase, inversely if the solar irradiance decrease, thus the performance of MPWM TPVI system is also decrease.

#### References

- [1] Alam H.M and Manfred D 2010 Assessment of renewable energy resources potential for electricity generation in Bangladesh *Renewable and Sustainable Energy Reviews* 14 (2010) 012.
- [2] Wu W, Wanf F and Wang Y 2014 A Novel Efficient T Type Three Level Neutral-Point-Clamped Inverter for Renewable Energy System *IEEE Explore*.
- [3] Maheshri S and Khampariya P 2014 Simulation of Single Phase SPWM (Unipolar) inverter *International Journal of Innovation Research in Advanced Engineering (IJIRAE)* 1 (2014) 006.
- [4] Kavidha B and Rajambal K 2006 Transformerless Cascaded Inverter Topology for Photovoltaic Applications *Proceedings of Indian International Conference on Power Electronics* 328-331.
- [5] Gonzales R, Lopez J, Sanchis P, Gubia E, Ursua A and Marroyo L 2006 High-efficiency transformerless single-phase photovoltaic inverter *IEEE Explore*.
- [6] Lopes O, Teodorescu R. and Gandoy J.D 2006 Multilevel transformerless topologies for single-phase grid-connected converter *IEEE Explore*.

- [7] Yang B, Li W, Deng Y, He X, Lambert S and Pickert V 2006 A novel single-phase transformerless photovoltaic inverter connected to grid *IEEE Explore*.
- [8] Kusakawa M, Nagayoshi H, Kamisako K and Kurokawa K 2011 Further Improvement of a Transformerless, Voltage-Boosting Inverter for AC Modules *Solar Energy Materials & Solar Cells* 67 (2007) 008.
- [9] Patrao I, Figueres E, Espin F.G and Garcera G 2011 Transformerless Topologies for Grid-Connected Single-Phase Photovoltaic Inverters *Renewable and Sustainable Energy Reviews* 15 (2011) 008.