

PAPER • OPEN ACCESS

Dielectric Properties Measurement and pH Analysis for Drinking Water

To cite this article: Wee Fwen Hoon *et al* 2020 *IOP Conf. Ser.: Mater. Sci. Eng.* **864** 012162

View the [article online](#) for updates and enhancements.

You may also like

- [Water Quality Evolution in Gozna and Secu Reservoirs, Semenic Mountains, Romania](#)
Andrei Armas, Robert Beilicci and Erika Beilicci
- [Analysis on the spatiotemporal characteristics of water quality and trophic states in Tiegang Reservoir: A public drinking water supply reservoir in South China](#)
Yun-long Song, Jia Zhu, Wang Li et al.
- [The Water Quality Characteristics and Quality Status of Bengkulu River and Nelas River, Bengkulu Province: Conditions for The Last Six Years](#)
I Khalik, A Sapei, S Hariyadi et al.



UNITED THROUGH SCIENCE & TECHNOLOGY

 **The Electrochemical Society**
Advancing solid state & electrochemical science & technology

**248th
ECS Meeting**
Chicago, IL
October 12-16, 2025
Hilton Chicago

**Science +
Technology +
YOU!**

**Register by
September 22
to save \$\$**

REGISTER NOW

Dielectric Properties Measurement and pH Analysis for Drinking Water

Wee Fwen Hoon¹, Yew Been Seok², Soh Ping Jack³, Lee Yeng Seng⁴ and Lee Oon Keng¹

¹Bioelectromagnetics Research Group (BioEM), School of Computer and Communication Engineering, Universiti Malaysia Perlis (UniMAP), Kampus Pauh Putra, Perlis, Perlis-Arau, 02600, Malaysia.

²Faculty of Innovative Design and Technology, Universiti Sultan Zainal Abidin, Kuala Terengganu, Terengganu Darul Iman, 21030, Malaysia

³Advanced Communication Engineering Centre, COE, School of Computer and Communication Engineering, Universiti Malaysia Perlis, Kampus Pauh Putra, Perlis, 02600, Malaysia.

⁴Department of Electronic Engineering Technology, Faculty of Engineering Technology, Universiti Malaysia Perlis (UniMAP), Perlis, Malaysia.

E-mail: fhwee@unimap.edu.my

Abstract. Every material has its own dielectric properties and it is also the same for water. In this research, dielectric properties measurement on water will be done to examine the water quality of drinking water whether it is safe to drink or not. Water quality in Malaysia, as well as access to water in general, is a major problem. The primary pollutants present in the water are oils, rubbish, suspended solids, sewage and toxic substances. These are consequences of untreated or only partially treated sewage caused by human activities. Thus, water quality in Malaysia is currently of some concern. The normal drinking water pH range mentioned in World Health Organization (WHO) and National Drinking Water Quality Standards (NDWQS) guidelines is between 6.5 and 8.5. The water may contain some residue even though the pH is in the range of 6 to 7.5 so it does not prove that the water is safe enough for drinking purpose. Thereby, the analysis about the water quality using the specific measuring instruments need to carry out to prove that the water in neutral pH may not be safe to drink as the pH does not prove the content of the water as clearly as dielectric properties. High Temperature Coaxial Probe as the dielectric properties measurement sensor will be used to provide better information compare to pH. The measurement parameters that had been used to determine the water quality is the dielectric constant. The results obtained from both pH and dielectric properties measurement values are been analyzed and compared and it shows that pH value for clean and contaminated water is at almost similar values while dielectric properties results show different for both clean and contaminated water.

1. Introduction

Water is one of the renewable natural resources which covered about 70 percent on the Earth's surface. The sources of water can be found on sea, river, lake, glaciers and even in the air. It is very important for the survival of all living organisms in Earth no matter how small or how large its size is. In chemistry perspective, the combination of hydrogen and oxygen atoms H₂O is the chemical formula



for water. The water is made up of two “H” atoms and one “O” through covalent bond. Water can found in different form which are ice (solid), water (liquid) and vapour (gas) [1].

The main water sources in Malaysia can be found on rivers, groundwater and streams. All of these sources are highly depended on rainfall. In the journal, it stated that the average annual of rainfall in Malaysia is in the range of 2000 mm to 2500 mm. According to the researcher, the water demand estimated will be around 14 billion m³ in 2020 while the groundwater are not able to fulfil the water demand as it only consists of 1% of total demand. For the river, the high pollution level makes the drinkable water become less and less from year to year [2].

Another source that can be found commonly nowadays is the bottled mineral water. However, the previous studies [3] have shown that the mineral water manufactured by factory is not reliable compared to the water tap. Besides that, it is very important to make sure the water is safe to drink. One of the methods to check and to measure the safety of drinking water is directly depend on the pH value which the range of neutral level is considered safe to drink as shown in table 1.

Table 1. Drinking water quality standards by Malaysia Government [4].

Parameter	Acceptable Value (mg/litre)	
	Natural Water Quality	Suitable Water Quality For Drinking
pH	5.5-9.0	6.5-9.0

Every material include water has its own unique dielectric properties. For this research, measurements on of these properties has been done where it had provided us information which to monitor quality control of water. Addition to this, the microwave sensing method (High Temperature Dielectric Probe) is found to be one of the best technologies used to measure the dielectric properties of water. Therefore, the effect of chemical concentration on the complex dielectric permittivity of water using open-ended coaxial probe will be studied and investigated.

2. Experimental

2.1. Sample preparation

The samples are 1 cup of purely clean water from a bottle of drinking water and 3 cups of clean drinking water with additional of soil or sand as can be seen in figure 1. The 3 cups of clean water contained of clean drinking water with added of 1, 2, and 3 teaspoons of soil in figure 1 (a) and the same mixture as in figure 1(a) but sand had been replaced the soil. All of these samples will then be tested with pH meter to make sure it is safe before proceed to the dielectric properties measurement step.

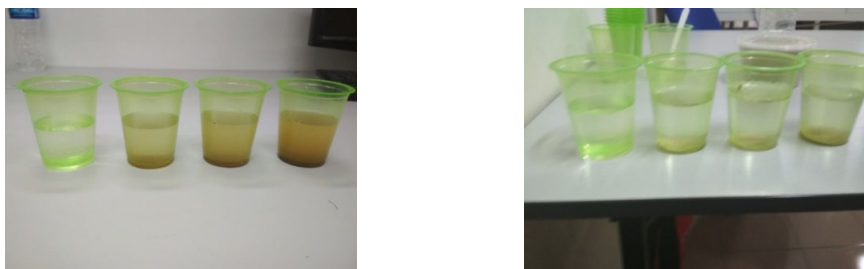

Figure 1. Four cups of water with added (a) soil (b) sand.

2.2. Measurement Setup

High temperature dielectric probe had been chosen as the measurement tool is due to it can measure liquid form material and proven to provide more accurate reading compare to the other methods. The coaxial probe measurement techniques require a network analyzer (VNA) to perform measurement and calculation for the dielectric constant results. A vector network analyzer (VNA) consists of a signal source, a receiver and a display and it is generally use to measure both the phase and magnitude of signals related to frequency. The right choosing of VNA is also important as it is specified to work over certain frequency range. Random errors due to noise, drift, or the surrounding environment make a microwave measurement susceptible to errors from small changes in the measurement system. Good measurement practices are need, such as checking all connectors for dirt or damage with the purpose to avoid and reduce the reading error.

The Vector Network Analyzer (VNA) is integrated with 85070E software which is to configure, calibrate and retrieve both dielectric constant measurements easily. The software will displays the measurement results in a variety of graphical and tabular formats. The software can print or plot the results and save the results or the test setups to disk. The VNA allows the software to calibrate out the errors during measurement which can help us to enhance the accuracy. The whole dielectric properties measurement setup (combination of vector analyzer and 85070 E software) can be seen in figure 2.

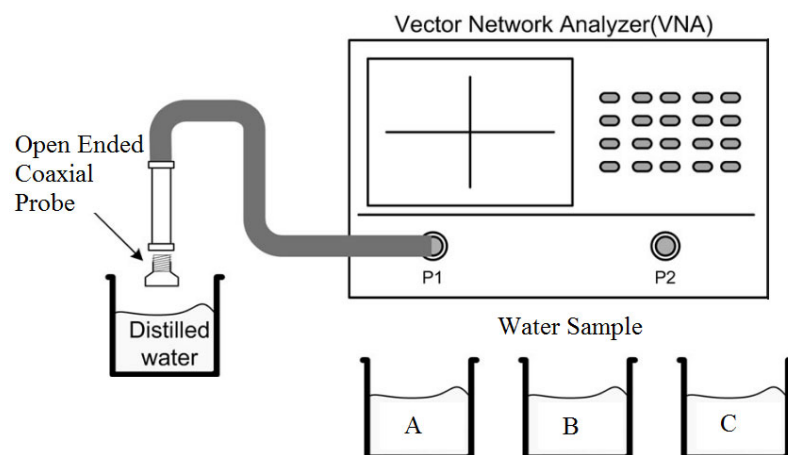

Figure 2. Dielectric Properties Measurement Experimental Setup.

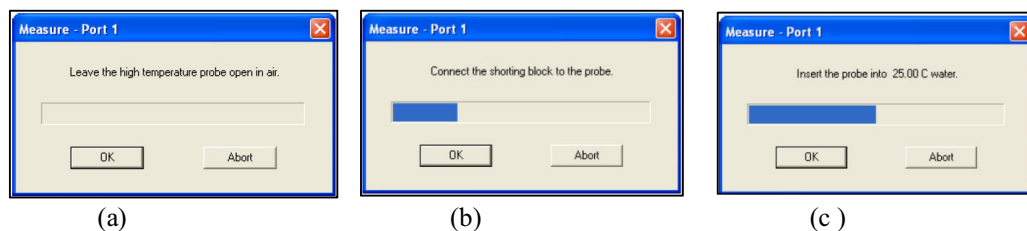

Figure 3. High Temperature Dielectric Probe Calibration (a) air (b) shorting block (c) water.

Before the measurement, the dielectric probe system needs to be calibrated such that the results obtained are accurate. The first step is that the frequency range is set from 1 GHz to 18 GHz. Then the default calibration standards which are air, short circuits, and water as the panel window shown in

figure 3 will be done after the frequency setting. The calibrated information is stored in the vector analyzer memory system.

After calibration, clean water will be measured at the first place to act as a reference result to compare with the other material under test (MUT) results. The dielectric probe will be needed to immerse into the water completely to ensure correct result popping up. After obtaining the dielectric properties of water results which is at range of 77-79, then only the next measurement on MUT can be confidently done. The measurement result will be displayed on the vector analyzer screen as shown in figure 4. Two panels can be seen in the screen which is graph and raw data. In the graph, the real part of the complex permittivity, ϵ' is the dielectric constant while the imaginary part of the complex permittivity, ϵ'' is the dielectric loss. Loss tangent also define as the ratio of the imaginary part to the real part of the complex permittivity which is the ratio of dielectric constant to loss factor.

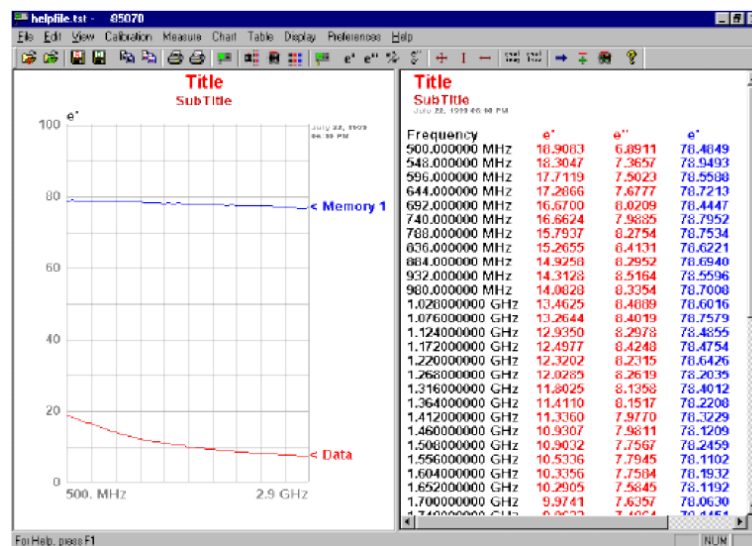

Figure 4. Water sample result of dielectric constant and loss.



Figure 5. pH measurement.

The reading of pH value will be taken from each of the samples. The pH meter is immersed into the sample for few minutes as demonstrated in figure 5. The reading will only be taken after the value stay at a constant reading. After each reading, the pH meter must be clean first before take the reading for the next samples.

3. Results and Discussions

Table 2 shows the pH reading for all clean and contaminated water samples. The pH reading in table 2 shows there are slightly different either drop or increase of pH value for different mixture of water with soil or sand. The results also show that the water with the added soil have the almost same pH value as the clean water. The pH reading is in the range of 6.8 to 7.2 which had been claimed safe to drink according to WHO and NDWQS. Even some of water had been contaminated with sand or soil, the pH reading still show that it is safe to be consumed. Hence, depending only on pH value of water is inaccurate to show that whether the water is safe to drink because the pH value seem to be almost same for clean water and contaminated water (added with soil and sand). It is obvious with the added of soil or sand means the water is dirty and will risk to living thing if they consume it. Thus, dielectric measurement technique is needed to be carried out for further in depth water testing to determine the quality of drinking water.

Table 2. pH of all water samples.

Water	pH Value
Water only	7.1
Water + 1 teaspoon of sand	6.83
Water + 2 teaspoons of sand	6.85
Water + 3 teaspoons of sand	6.84
Water + 1 teaspoon of soil	7.2
Water + 2 teaspoons of soil	7.18
Water + 2 teaspoons of soil	7.12

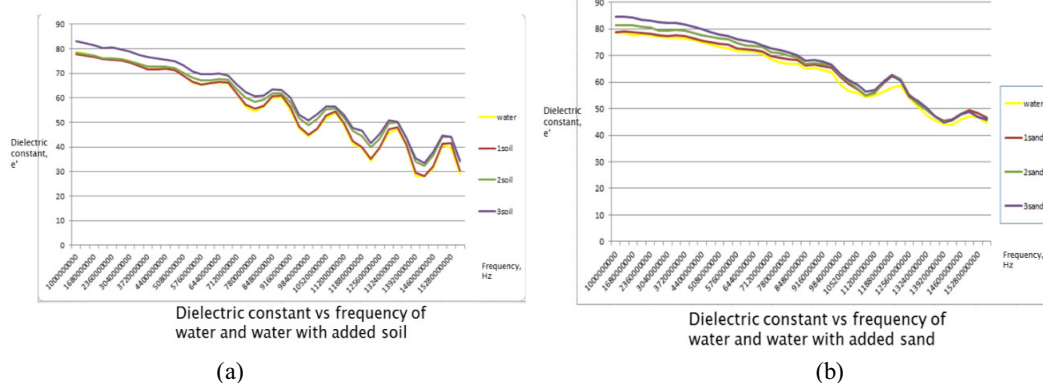

Figure 6. Comparison of water and the water with added (a) soil (b) sand.

From the graph in figure 6, the different between the dielectric properties of normal clean water and water with the added soil or sand can be observed. At 1 GHz, the dielectric constant for clean drinking water is at $\epsilon' = 77$ while the highest dielectric constant value for mixture of drinking water with soil and sand are 82 and 84 respectively. From the results, frequency range from 1 GHz to 18 GHz is chosen so

that the difference of the reading can be seen for a broad range of frequency. The big different of dielectric constant value between clean water with contaminated water shows that dielectric properties measurement technique able to lead the vector network analyzer in detecting the impurities which will make the dielectric constant to be higher compare to the clean water. Thus, the results of dielectric properties show that contaminated water will have higher dielectric constant value as compared to clean water. This also means that the dielectric properties measurement technique using high temperature dielectric probe able to give accurate result for water quality determination compare to pH measurement technique.

4. Conclusions

As a conclusion, dielectric properties are the properties that determine the interaction of electromagnetic energy with water when subjected to dielectric heating. From the graph in figure 6, it shows the consistency in the measurements obtained for the clean and the mixture of soil or sand for multiple water samples prove the reliability of this measurement tool and the data reported. Hence, from the result and analysis, it can be concluded that the relative permittivity for the safety water to drink is at the value of 77 at 1 GHz. Furthermore, high temperature dielectric probe used as tool to determine the safety of drinking water. An accurate calibration technique is critical to achieve consistency, accuracy and reliability. Water samples were measured over a fixed frequency range which is from 1 GHz to 18 GHz and the results showed more diverse differences in dielectric constant of each samples compare to the pH. Therefore, we strongly recommend using dielectric properties to determine the safety of water compare to pH.

References

- [1] Nurul Hafiza A R, Sarva M P, Ahmad Z A and Zailina H 2015 *Journal of Epidemiology and Global Health* **5** 297
- [2] Casey Ng 2016 *Utar Agriculture Science Journal* **2** 36
- [3] Cidu R 2011 *J. Food Compos. Anal* **24** 184
- [4] Health Department of Federal Territory Kuala Lumpur & Putrajaya 2016 Drinking Water Quality Standard. (Online): <http://kmam.moh.gov.my/public-user/drinking-water-quality-standard.html>. (Accessed: 1 December 2017).