

# The Design of a Surge Protector for Low Voltage Equipment (Class A)

AMIZAH MOHD ARIFFEN<sup>1</sup>, ABD. MALEK<sup>1</sup>, ISMAIL DAUT<sup>2</sup>  
AND KAMSANI ABDUL MAJID<sup>3</sup>

<sup>1</sup>Fakulti Kejuruteraan Elektrik, UTM Skudai

<sup>2</sup>PPK Sistem Elektrik, KUKUM

<sup>3</sup>TNB Research

---

## ABSTRACT

*Various international standards have specified the requirements and applications of low voltage protection devices. This paper aims to study those requirements and application guidelines for the purpose of designing and constructing suitable protective equipment of Class A category. In this case, Surge Protector Category A is focussed because the service entrance Surge Protection Device (SPD) provides the first line of defence against electrical transients for a facility by diverting high energy, outside surges to ground and it also lowers the energy to a level that can be handled by downstream devices closer to the load. A surge protector is a device that keeps power levels constant against power line fluctuations which cause by lightning mainly and if is not used, fluctuations in the power line can potentially have drastic effects on the equipment such as computer. Therefore the proper coordination of surge protective device specified for Class A category is required to avoid damaging SPDs installed on distribution panels or locally at vulnerable equipment. Class A protection is a protection between the outlets and the long branch circuits and equipment.*

---

## INTRODUCTION

The word 'surge' refer to an over voltage of very short duration, lasting less than a few milliseconds. A current surge or voltage surge is a transient that is abnormally high pulses of voltage or current that exceeds the circuit's normal operating rating. These transients generally are random in nature and may occur for ten nanoseconds to a few milliseconds. The cause of a surge is typically lightning or electrical switching [1].

Surges produced by electrical switching are typically lower in magnitude and longer in duration than those originating from lightning. Nevertheless, appropriate selection of surge protection schemes can serve for both phenomena.

Lightning is a very conspicuous source of surges, and almost everyone has seen or heard about its destructive effects. Direct effects result from the lightning striking an object. Indirect effects occur when a surge is induced by a nearby strike

or carried by power system conductors to the service entrance of the buildings. Lightning effects can occur at all levels of the electric power system: transmission, distribution, and secondary circuits [1]. From the consumer's point of view, the further away the lightning strikes, the lesser the effect. Only a small portion of the total lightning current will appear at the service entrance of a residence or other building: a few kilo amperes at the most, compared to the tens of kilo amperes in the lightning strike itself. However, a voltage surge at the service entrance—as high as several kilovolts—can occur even if the lightning strike was far away.

The major mechanisms by which lightning produces surge are:

- a) A nearby lightning strike to objects on the ground or between the cloud layers provides electromagnetic fields, which can influence voltages on the conductors of primary and secondary circuits.
- b) A nearby cloud to ground discharges couples which lead to the lightning ground-current flow onto the common ground impedance paths and causing voltage differences across its length and breadth.
- c) The rapid drop of voltage during an operation of primary gap-type arrester. Other are a direct lightning strike to high voltage primary circuits injects high currents into the primary circuits and a direct lightning strike to the secondary circuits which is very high currents resulting voltages exceed.

## FUNDAMENTAL OF SURGES PROTECTION

Protection against surges can take three forms [4], firstly by, prevent the occurrence of surges at their origin (impossible for lightning and difficult for surges associated with normal operation of the power system). Secondly, divert the surge to ground as it impinges on the building and before it enters the building (the most effective approach). The third approach is clamp the surge by a Surge Protective Devices (SPD) either by an add on plug in or one built into an appliance.

However, only the last two forms of protection are practical because the first one is clearly beyond the control of a residential occupant. On a surge protector selection tips, a single-line surge protector usually protect between hot and neutral wires [2]. This provides minimal protection, which may be adequate for areas and environments that are very stable. Therefore, for a better protection a three-line surge protector is recommended. A three-line surge protector protects the load between hot and neutral wires (L-N), hot and ground wires (L-G), and neutral and ground wires (N-G). This offers more comprehensive protection and has a separate fuse for each line. The effectiveness of three-line protectors also depends on the construction of the device. This includes the speed with which it works and the voltages it can handle, block, or absorb.

## Surge Protector Classification

The performance characteristics for SPD are rated according to three specifications:

### **Grade:**

Grades A, B, and C specify endurance testing performance at different surge currents or type of applied surge.

### **Class and Mode:**

Class 1, 2 and 3 specifies the Suppressed Voltage Rating (SVR) under the endurance testing test conditions or type of let-through voltage. Three specific levels of SVR are used, Class 1 = 330V, Class 2 = 400V, Class 3 = 500V. An SVR of 330V means that during the endurance testing, the measured suppressed voltage (let-through voltage) did not exceed the SVR of 330V. This should not be confused with 'clamping voltage' which often means the voltage at which clamping begins. Mode specifies whether surges are diverted to the ground wire. Mode 1 is the ground protection mode, 'L-N mode' or 'Normal Mode' which suppresses surges line to neutral. Mode 2 is 'All Mode' suppression, which includes diversion to the ground wire.

## System-specific Protection Schemes

Several types of utility services can be found in a building, each with a different method of surge protection, although each is based on the same set of fundamental concepts and implementations of protective devices. A basic approach to protection against unavoidable surges is shown in Figure 1. Two stages of parallel-connected SPDs divert or clamp the surge, while series impedance decouples the two stages and restricts the propagation of surges.

The three categories of services-electric power, telephone, and communication- may use different practices for surge protection as a result of their intrinsic characteristics and constraints. As shown in Figure 2, two stages surge protection in the power system may take the form of providing protection at the service entrance (left side of the figure), followed by form of providing protection at the service entrance (right side of the figure).

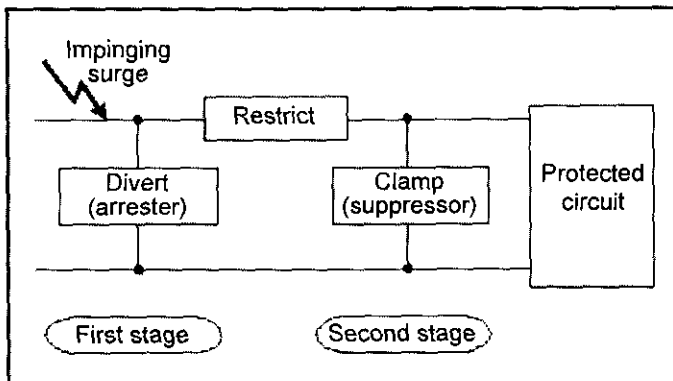

**Figure 1:** Basic two step protection against surges impinging on an installation.

The first stage protection can be implemented at the weather head (1), as a meter base adapter (2), or at the service panel (3) or (4). The second stage protection can be implemented as a built-in receptacle (5) or plug in SPD (6). In the language of NEC, location (1) through (5) can be considered as part of the premises wiring system. Some distribution systems also use an SPD at the terminals of the distribution transformer (0).

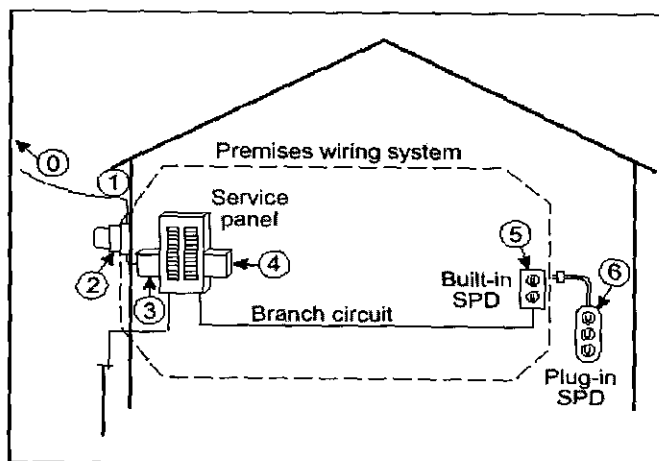

Figure 2: Possible location for SPDs in the power system.

## Surge Protective Devices

The service entrance SPDs are intended to lower the severity level of a very large surge to a level that can be handled by other SPDs closer to the appliances. SPDs use non linear components to divert surge currents, generally to ground, while maintaining a limited voltage across their terminals to protect appliances these non-linear components can be classified into two categories, clamping SPDs (voltage limiting SPDs) and voltage switching SPDs (crowbars). (Refer Figure 3 for the graphic symbols used to designate SPDs).

**Clamping SPDs** have a highly non-linear I-V characteristic. That is the voltage across them increases only a little for a large increase in the current flowing in the SPD. Figure 4 shows this characteristic with log-log coordinates, where a six-decade range of current produces a change in the voltage only by some percent. At the normal system voltage, a clamping SPD draws very little current, but when exposed to a surge, the current becomes large and clamping voltage is developed across the clamp, so that energy is dissipated in the device. Thus, energy-handling capability becomes a key factor.

**Voltage-switching SPDs** have different kind of non-linear behaviour that responds to the voltage across their terminals. When an impinging surge causes the voltage across the terminals of the crowbar to exceed a certain value, spark over occurs and the subsequent voltage is much lower, in a range of few tens of volts.

The energy dissipated in the crowbar, for diverting the same current as a clamp, is much lower because the voltage at the terminals is much lower. Thus, rather it is simply the current amplitude and duration, which is important.

**Hybrid surge protective devices** include several types of coordinated components to give broad protection. They can include gas tubes discharge to divert high-energy surges, metal oxide varistors to divert medium-energy surges, and silicon avalanche diodes for low-energy surges. The hybrid SPD (Figure 5) uses a combination of crowbar; clamping and series components to both divert and restrict unwanted energy from the protected system. In this case, high frequencies and high voltages (impinging from the left side) are kept from the system (right side). Note that such an SPD can be used only for one direction of propagation of the surge, as shown on the figure.

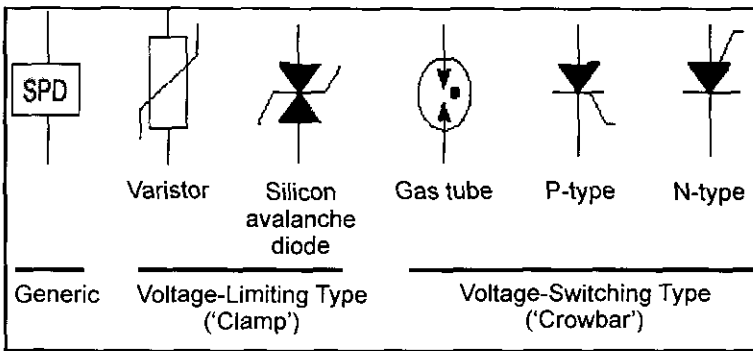

**Figure 3:** Graphic symbols used to designate SPDs.

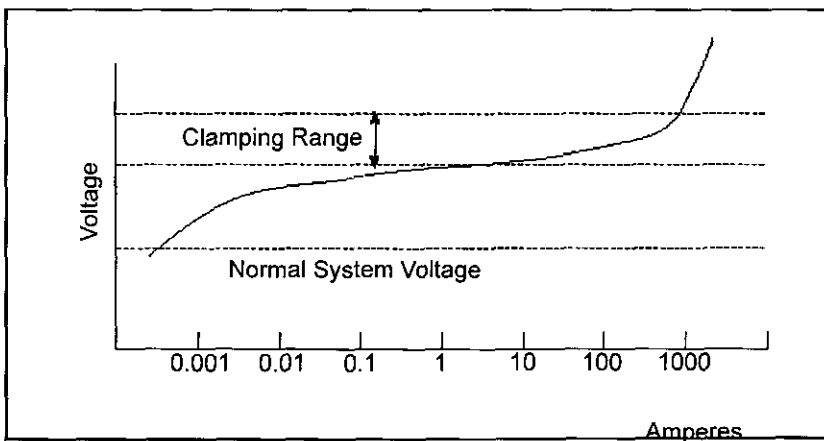

**Figure 4:** Typical I-V characteristic of clamping SPD.

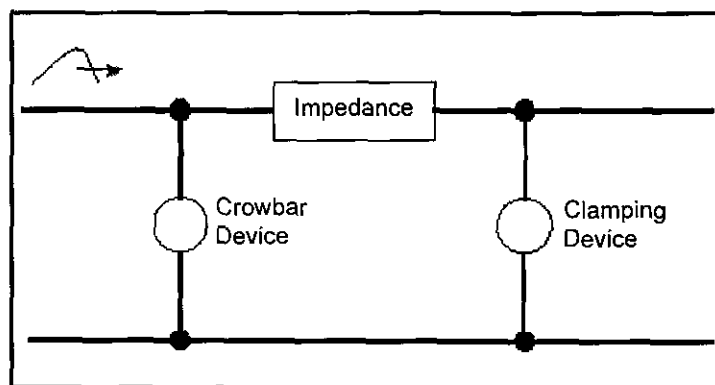

**Figure 5:** Hybrid SPD combining components to divert and restrict surges.

## SPECIFICATION OF CIRCUIT DESIGN

### Methodology

Listed below are the methods used in this project:

1. Gathering the literatures or information from the international standards, handbooks, journal and conference papers.
2. Researching and analysing protection circuits by various manufacturers of SPD product available in the market.
3. Designing and constructing a protection circuit.
4. Previewing the components
5. Conducting experimental tests to the designed circuit according to standard test methods as stated in IEEE Standards Test Methods for Surge Protectors Used in Low-Voltage Data, Communications and Signaling Circuit (IEEE Std C62.36-2000).
6. Modification on the protection circuit.
7. Final product.

### Design and Operation of Circuit

This SPD is using voltage-limiting type (clamp) component which is metal oxide varistor (MOV). Varistor is chosen because it has shown themselves as excellent protective devices regarding to their application of flexibility and high reliability. MOV with its extremely attractive price and performance ratio is an ideal component for limiting surge voltage and current as well as for absorbing energy. MOV does nothing if the voltage is correct and only functioning if the voltage is too high, because it can conduct a lot of current to eliminate the extra voltage.

To choose a proper varistor involves four steps:

1. Select a varistors that are suitable for the operating voltage. As the protective

circuit is design for main voltage supply 240 Vrms, therefore operating voltage for the varistor must be higher than 240 Vrms ( $V_{MOV} > 240 V_{rms}$ ).

2. Determine the varistor that is the most suitable for the intended application in terms of surge current, energy absorbtion and average power dissipation.
3. Determine the maximum possible voltage rise on the selected varistor in case hsrve over voltage and compare this to the electric strength of the component or circuit that is to be protected.
4. Choose a type with a larger disk diameter, because the protection level is lower for the same surge current as the current density is reduced.

Therefore the circuit used a varistor, which has operating voltage 250 Vrms with a large disk diameter (22.5mm) for a better reduction of current density. The varistor model S20K250 was chosen with the technical data and protective level is described in Table 1 and Table 2 below.

Referring to the circuit, it is designed as in the arrangement. The MOVs that are close to the source of the surge, MOV 1 and MOV 2, will begin to clamp very quickly when the surge occur in live (L) line. Then the MOV 3 will clamp the excess surge current before it goes via equipment that will be protected. So it means all the MOV will operate when surge coming from the live (L) line.

When the surge is coming from the neutral (N) line, only MOV 2 will operate and then divert the surge to the ground. While D1, D2, R, LED-G and LED-R represent as the indicator circuit. If the green LED only turn on it signify the line connection is normal, but when the red LED (both include green LED) turn on it determined that the line connection is not safe.

The thermal circuit breaker series connection at live (L) only for AC operation, which it will trip if there is a short circuit or severe surge that causes excessive current to flow.

The surge protector circuit is shown in Figure 6 below.

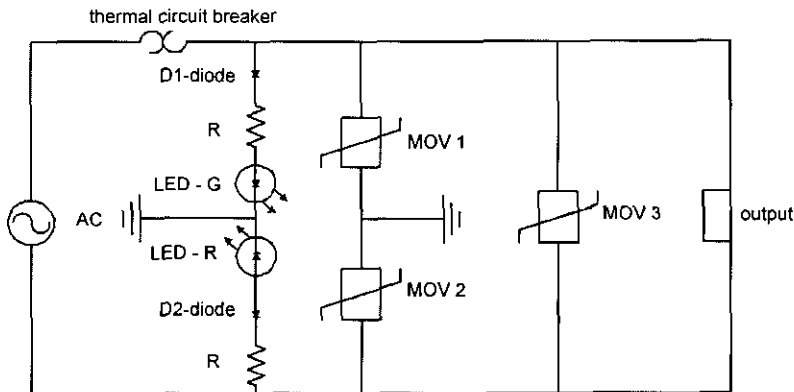

**Figure 6:** The Surge Protector Circuit.

**Table 1:** Technical data for MOV - S20K250.

Operating voltage, $V_{rms}$ ( $T_A = 85^\circ\text{C}$ )	250 v
Operating voltage, $V_{dc}$ ( $T_A = 85^\circ\text{C}$ )	320 v
Peak transient current, $I_{max}$ (8/20 $\mu\text{s}$ )	3 kA
Energy absorption, $W_{max}$ (2 ms)	140 J
Average power dissipation, $P_{max}$	1 W
Operating temperature, $T_A$	-40°C to +85°C
Storage temperature	-40°C to +125°C
Electric strength	$\geq 2.5$ kV
Insulation resistance	$\geq 1.0$ k $\Omega$
Response time	< 25 ns

**Table 2:** Protective level (characteristic,  $T_A = 25^\circ$ ).

$V_v$ (1 Ma)	390 V
$G V_v$ (1 mA)	-10% to + 10%
Maximum clamping voltage	$V = 650$ V $I = 100$ A
$C_{tp}$ (1 kHz)	700 pF

**EXPERIMENTAL RESULTS**

The circuit is tested by applying surge waveform 1.2/50  $\mu\text{s}$  Combination Wave as stated in IEEE Std C62.36-2000 [12]. The Combination Wave is delivered by a impulse generator that applies a 1.2/50  $\mu\text{s}$  voltage wave across an open-circuit and an 8/20  $\mu\text{s}$  current wave into a short-circuit. The exact waveform that is delivered is determined by the impulse generator and the impedance to which the surge is applied. (Refer to Figure 7a and 7b)

High voltage impulse with 3 kV peak open-circuit voltages was generated to test the surge protector circuit (Refer Figure 8). Two tests were taken where:

- a) Impulse is applied at L-G – measure the voltage at L-G, N-G and total current flow
- b) Impulse is applied at N-G – measure the voltage at L-G, N-G and total current flow

Figure 9, shows the result when the surge is injected at L-G. When the surge is applied, the circuit clamped the 3kV input to 870V at L-G and 514V at N-G line. Figure 10 indicate the result when surge is applied at N-G. The 3kV surge is clamped to 860V at N-G and 500V at L-G line.

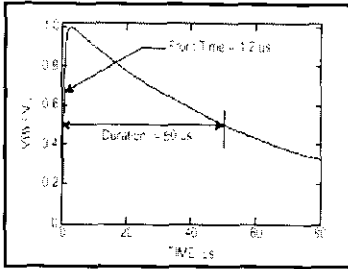

(a) Open-circuit voltage

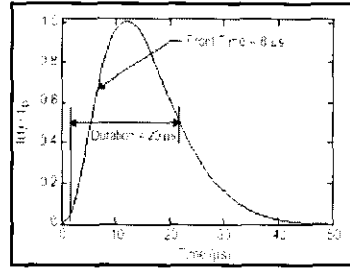

(b) Short-circuit current

Figure 7(a) and (b): Combination Wave.

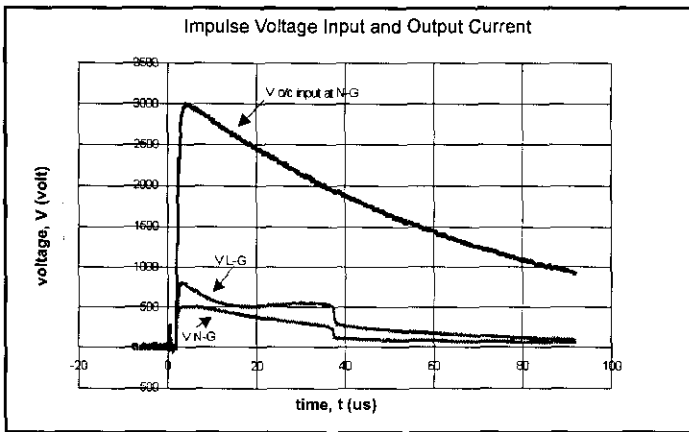

Figure 8: Graph of total current flow for both conditions.

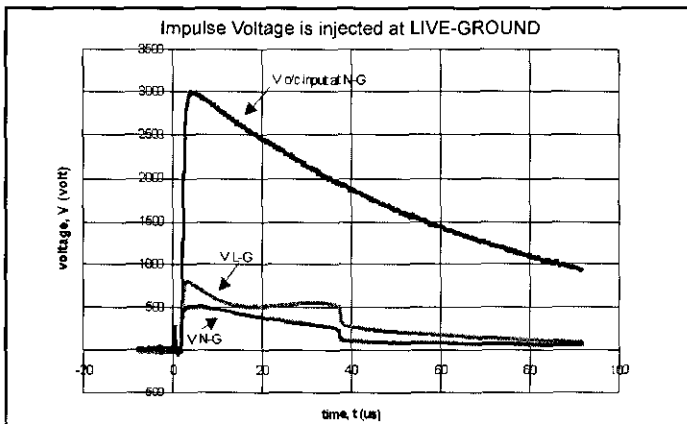

Figure 9: Output graph when surge is injected at L-G.

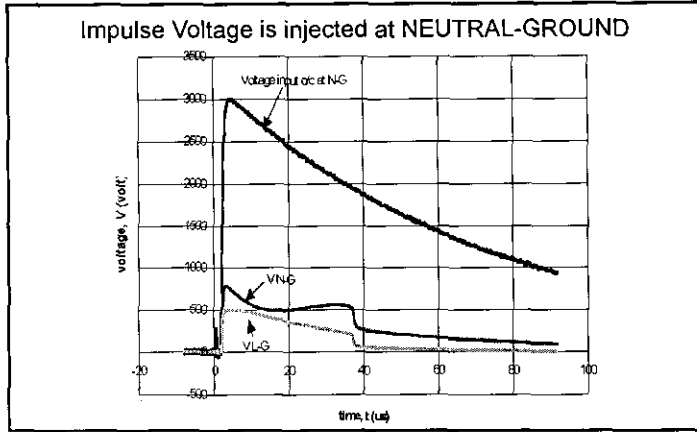

Figure 10: Output graph when surge is injected at N-G.

## DISCUSSION

Power lines need not suffer from direct lightning hits to develop harmed high voltage spikes, swells, surges and interference. Therefore, proper and complete protection must include location C, B to A of Figure 11 because of the wide range of possible surges that can exist. The surges are severe enough to implicate immediate appliances damage. The fundamental in design of surge protection describes different location categories A, B, C each with a same voltage levels but decreasing available surge current as the length of the branch circuit increases.

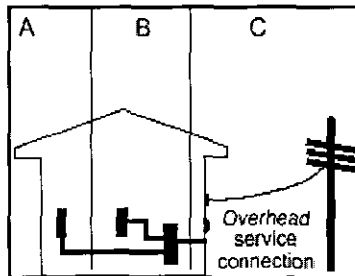

Figure 11: Location Categories from ANSI/IEEE C62.41.

High achievement protective systems, clamp power line surges to a secure limit hold overstress to a minimum level, thus prolonging appliances life. Therefore an indicator circuit is presented to indicate the protection is functioning normally. From the experimental result, clearly showed the surge protective circuit can eliminate the surge from power line by clamping the high voltage to the safe level but may not have high performance. The reason is, the total current flow both in L-G and N-G line still high that will may harm the equipment which to be protected. Therefore, this protective

circuit need of the available circuits provide filtering and regulator system to remove disruptive interference and regulate the voltage and current to desired levels.

This protective circuit is designed only to protect the power lines that are generally understood as a source of transients but it is not protect the communication line including telephone line which the surge often can occur too. There is several type of protector, which include the protection of communication line and the units usually cost a little more. Weighed against the cost of the equipment, shortened life system due to undetected surges, the added security is well worth the added cost.

## **CONCLUSION**

The designed of this surge protector circuit may not have high performance protective system, but it is cheaper than other products in the market. The protective system designed includes surge reduction and indicator circuit. Instead to improve the performance of this design, adding series resistance impedance at the final stage before surges enter the appliances to limit the large current that harm the equipment is needed. Besides, a multistage of protection is recommended by used of hybrid surge protective devices. With multiple stages of protection, different components are used to suppress a surge. The more the stages, the large the current that can be handled.

## **REFERENCES**

1. P.Hasse (1992). Overvoltage Protection of Low Voltage Systems. *IEEE Power Series*, Vol.12.
2. IEEE C62.41 (1991). IEEE Recommended Practice on Surge Voltages in Low Voltage AC Power Circuits. *Standards*.
3. Kithil, R (2001). NLSI Recommendations For Surge Protection Devices (SPD). *Technical Report*.
4. EPRI PEAC Corporation (1999). Recommended Practice For Protecting Residential Structures And Appliances Against Surges. *Final Report Document PEAZC.0545.R*.
5. Martzloff, F.D., and T.F. Leedy. (1989). Selecting Varistor Clamping Voltage: Lower Is Not Better!. *Proceedings of The Zurich International EMC Symposium*, pp 137-142.
6. Martzloff, F.D, and G.J. Hahn. (1970). Surge Voltages In Residential And Industrial Power Circuits. *IEEE Transactions On Power Apparatus And Systems*. 89(6), pp. 1049-1056.

7. UL 1449 (1996). Transient Voltage Surge Suppressor.
8. Engdahl, T. (1998). Main Surge Suppression, Mains Transient Surge Suppression, Telephone Line Surge Protection, Overvoltage Protection (RS-232 Surge Protection). *Article*.
9. Martzloff, F.D, and G.J. Hahn. (1970). Surge Voltages In Residential And Industrial Power Circuits. *IEEE Transactions On Power Apparatus And Systems*. 89(6), pp. 1049-1056.
10. Lai, J.S. and Martzloff, F.D. (1993). Coordinating Cascaded Surge Protection Devices: High-Low Versus Low-High. *IEEE Transactions on Industry Applications* 29(4), pp 680-687.
11. IEEE C62.36 (2000). IEEE Standard Test methods for Surge Protectors Used in Low-Voltage Data, Communications and Signalling Circuits. *Standard*
12. *EDN ACCESS* (1997). Design Feature.