

PAPER • OPEN ACCESS

Solar Powered Multiple Output Buck Converter

To cite this article: M. Z. Aihсан *et al* 2020 *IOP Conf. Ser.: Mater. Sci. Eng.* **932** 012075

View the [article online](#) for updates and enhancements.

You may also like

- [A Review on VSC-HVDC Reliability Modeling and Evaluation Techniques](#)
L Shen, Q Tang, T Li *et al.*
- [Practical aspects of partial discharge measurement for HVDC cables](#)
X Hu, A J Reid, E Corr *et al.*
- [2D MHD AND 1D HD MODELS OF A SOLAR FLARE—A COMPREHENSIVE COMPARISON OF THE RESULTS](#)
R. Falewicz, P. Rudawy, K. Murawski *et al.*



UNITED THROUGH SCIENCE & TECHNOLOGY

 **The Electrochemical Society**
Advancing solid state & electrochemical science & technology

**248th
ECS Meeting**
Chicago, IL
October 12-16, 2025
Hilton Chicago

**Science +
Technology +
YOU!**

Register by
September 22
to **save \$\$**

REGISTER NOW

Solar Powered Multiple Output Buck Converter

M. Z. Aihsan¹, N. Kimpol, Liew Hui Fang, M. I. Fahmi², W. A. Mustafa, J. A. M. Jobran, M. M. A. Kader

¹Electrical Engineering Technology, Faculty of Engineering Technology (FETech), Universiti Malaysia Perlis (UniMAP), Kampus UniCITI Alam, Sungai Chuchuh, Padang Besar 02100 Perlis, Malaysia.

²School of Electrical System Engineering, University Malaysia Perlis, 02600 Arau, Perlis.

Email: zaid@unimap.edu.my

Abstract: Times have certainly changed over the past few decades, now it seems that technology is getting more compact and efficient. The modern outdoor enthusiast such as hikers, climbers has a problem regarding the lack of power supply to power up electronics when they go for adventure activities. In order to solve this problem, this paper design and develop DC/DC buck converter system to drop down the voltage from the solar photovoltaic (PV) system from 12VDC into 5VDC. This paper is first to start up with design and simulation circuit using simulation to test outcome of this paper in the range of 5VDC & 1.0A and 5VDC & 0.5A. A battery storage is needed to feed electricity independent and battery management of the battery is needed to improve the performance of battery life. This can be done by adding a charge controller unit. The outcome of this paper allows the battery to be charged using the solar panel and at the same time can produce multiple outputs for low voltages used. The software simulation has been done to shows this system produces two different output and the hardware will be developed based on the software results. Software and hardware result, both will be compared and analysed.

1. Introduction

Nowadays the application of power semiconductor devices in electronics and electric power field is undeniable as most of the electrical converters consist of semiconductor elements. These semiconductor devices had undergone varies evolutionary and considered as the heart of modern power electronics [1]. One of the electrical converters is to convert the voltage level from any certain level of voltage to another level of voltage [2]. As in this project, the DC/DC buck converter is to buck down the input voltage to the desired output voltage.

This paper is focused on developing the portable multiple output buck converter with the photovoltaic (PV) as a system input. In Malaysia, solar PV systems are more selected compared to wind energy as Malaysia wind speed are less than 3 m/s [3]. To harness the small wind, vertical axis wind turbine is needed as the blade design will trap the small wind speed compared to the horizontal axis wind turbine [4], [5]. While for PV system, it need the suitable place as the PV panel need a good radiation at the desired location [6], [7]. The rechargeable battery will be applied as a storage system in this system. Thus, the power from the PV will charge the battery and at the same time will be supplied to the buck converter simultaneously. Consider the system running where is no present in



Content from this work may be used under the terms of the [Creative Commons Attribution 3.0 licence](https://creativecommons.org/licenses/by/3.0/). Any further distribution of this work must maintain attribution to the author(s) and the title of the work, journal citation and DOI.

sunlight as a source of PV panels, the battery will be a source of the system input. In Malaysia, the duration of harvesting the sunlight energy in the range of 8 hours per day and this country are blessed with adequate sunlight radiation throughout the year as it is near to the equator [8].

The output of this buck converter will produce two different output. The outcome of this project allows the battery to be charged using the solar panel and at the same time can produce multiple outputs for low voltages used. Moreover, this project will be a portable system that can be carried by the outdoor enthusiast in order to solve their problems where no supply to power up the electronics devices in the rural area.

2. Proposed Topologies and Operating Principles

2.1. Buck Converter Design

The topology for this buck converter are in the consideration of generating multiple currents flow for 0.5A and 1.0A as in Figure 1. It can be seen from Figure 1 the buck converter connected to two units of power resistor module. The value of those resistors are decided based on the current flow needed for each section.

For simulation purposes, the circuit connected to a simple DC supply as to testify the circuit functionality and testing the performance of the multiple output buck converter. The buck converter is design for meeting the requirement of 2.5W and 5W for multiple output section. The whole system lead to the complete connection together from PV System, the buck converter with its controller and lastly connect to the real load using USB ports.

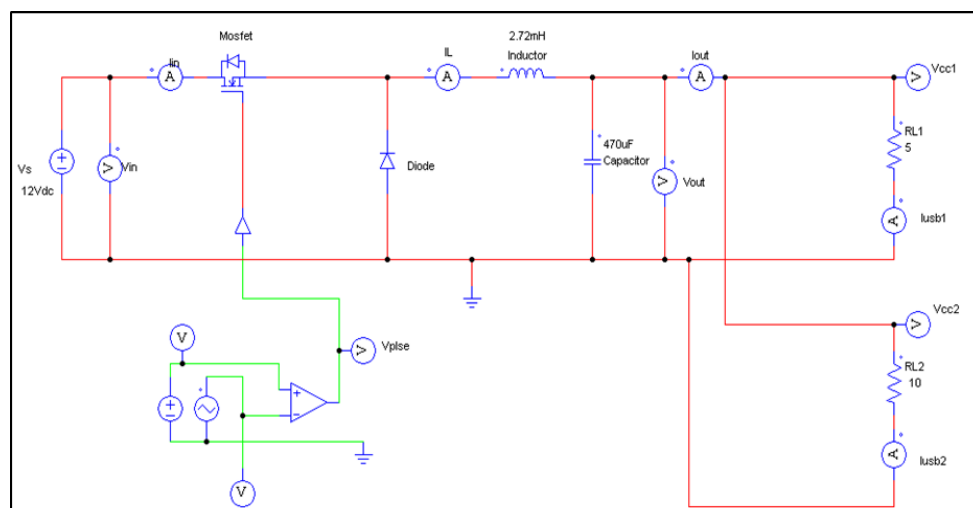

Figure 1. Proposed topology multiple output buck converters.

The solar panel will act as system input $12V_{DC}$. This DC input will be connected to the solar charge controller as to charge the battery and connect to the buck converter. In case the system still runs in a situation where is no presence of sunlight, the system will use a $12V_{DC}$ 7.2Ah Lead-acid rechargeable battery will act as the storage system and will be connected to buck converter. Thus PWM microcontroller will be injected into the MOSFET thru gate driver based on buck switching characteristic.

2.2. Operating Principles and Parameters

The buck converter in this system working on the CCM mode as CCM mode as it does not reach zero so at the end of every switching cycle and there is some energy left which will be use on the next cycle to provide enough energy for the output [9]. Since this project is designed specifically for charging, this criteria is badly needed. The generated power from solar PV will be injected to the solar charge controller for the purpose of gaining the stable output voltage to charge the battery and connected to

the buck converter [10]. The buck converter will operate in the rating of drop down of voltage from $12V_{DC}$ to $5V_{DC}$ that suite the USB power plug rating that can charge the mobile devices in the rating of $5V_{DC}$ and 1.0A. A good power cable need to be used as to sustain the high current that came from the solar PV [11].

The buck converter working on the operating parameters as in Table 1. There are two power wire wound resistors used in this buck converter as wire wound usually came with a good heat sink to stand up the heat generated due to the high current produce from the buck converter. The value of power resistors are 5Ω and 10Ω specifically for generating 1.0A and 0.5A respectively.

Table 1. Specification of Buck converter

Parameters	Value	
Input voltage, V_{in}	$12V_{DC}$	
Load resistance	5Ω	10Ω
Output current, V_{out}	1.0A	0.5A
Output voltage, V_{out}	$5V_{DC}$	
Switching frequency, f_{sw}	100kHz	
Conduction	CCM	

3. Hardware Implementation

The equivalent series resistance (ESR) may have a significant effect on the output voltage ripple, often producing a ripple voltage greater than that of the ideal capacitance [12]. The inductance in the capacitor is usually not a significant factor at typical switching frequencies [2]. In order to reduce the output voltage ripple, $\Delta V_o / V_o$ the capacitor value must calculate specifically. The value of the capacitor is first assumed to be $470\mu F$. The value of this parameter will be tested using PSIM software simulation. Thus, the output of the waveform will observe and the behavior of the output voltage also was analyzed. To calculate the desired value of capacitor need by this buck converter, the average value of the maximum and minimum voltage waveform must be determined. Figure 2. below shows the output voltage on a small scale.

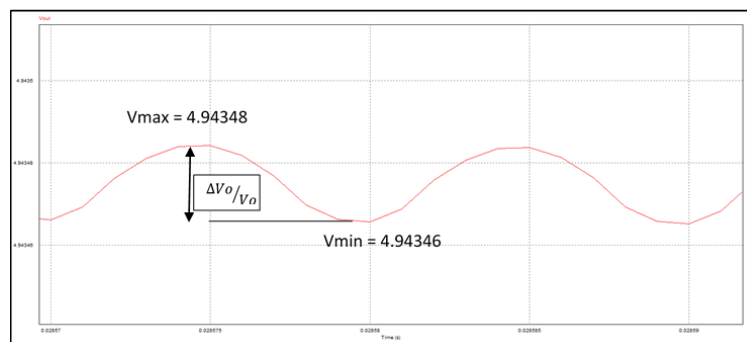

Figure 2. Output voltage ripples

From the figure above the value of output voltage ripple can be calculated using a mathematical formula [2],

$$\frac{\Delta V_{out}}{V_{out}} = \frac{V_{out}(1-D)}{8 \times C \times L \times f_{sw}^2} \quad (1)$$

$$\frac{\Delta V_{out}}{V_{out}} = 3.7 \mu$$

Thus, the actual value of the capacitor can be computed from the equation,

$$C = \frac{V_{out}(1-D)}{8 \times \frac{\Delta V_{out}}{V_{out}} \times \Delta L \times f_{sw}^2} \quad (2)$$

$$C = 24.49 \mu F$$

4. Results

4.1. Laboratory test

The result is obtained from the experiment in which the PWM duty cycle was changed from 30% to 42% ON. Thus, The PWM was injected into the microcontroller and both outputs of the buck converter were manually measured using a digital multimeter. In this experiment, the laboratory power supply was used. Figure 3. (a). shows the circuit of this system were set up and the output of the buck converter was measured with a digital multimeter. It can be seen that the developed converter was able to conduct both system for 2.5W and 5W system.

In this experiment, the coding of the duty cycle of 30% to 42% will be injected into the microcontroller. Thus, both output of the buck converter will be connected to charge the smartphone. The charging time will be recorded in every increase 5% of the smartphone battery percentages. Noted that the model of smartphone that has been used in this experiment are Lenovo A390. The experimental data has been recorded and analyzed for the performance of the charging speed analysis purposes. Figure 3 (b) shows the circuit of this system were set up and the output of this system is connected to the smartphone using the USB port.

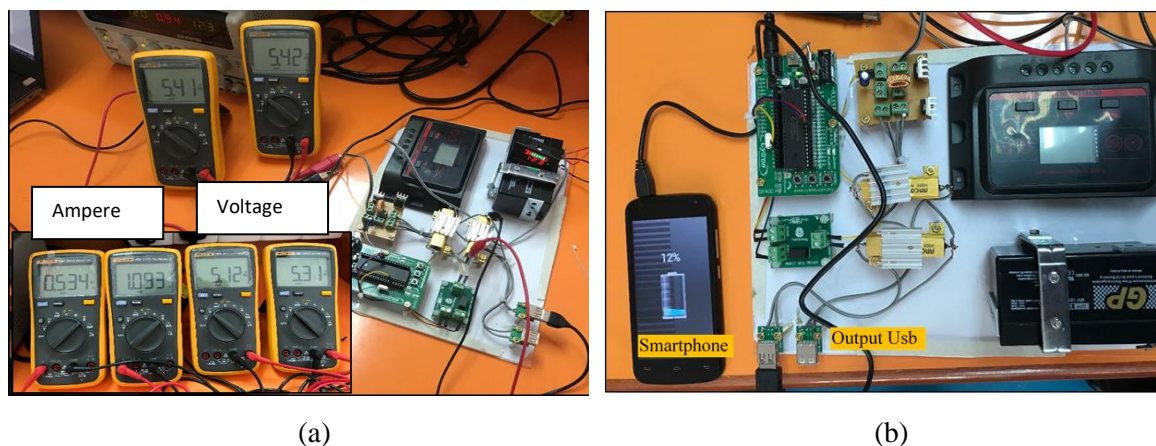
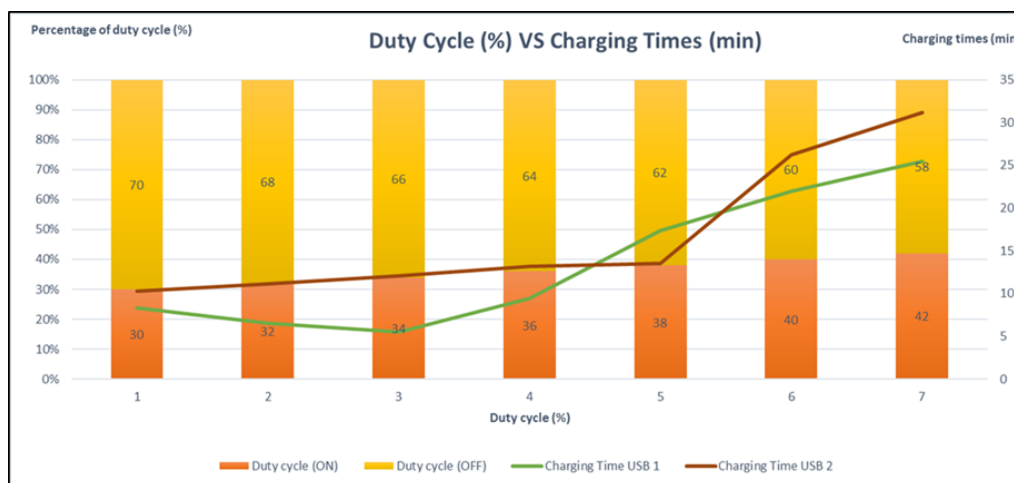

Figure 3. (a) Output results for both 2.5W and 5W buck converter system (b) Circuit configuration to the real mobile load

Table 2. The duty cycle and the recorded charging time of both output buck converter.

Duty Cycle (%)		Charging Times of Output USB 1 (min)		Charging times of Output USB 2 (min)	
ON	OFF	0-5%	0-10%	0-5%	0-10%
30	70	8.3	16	10.3	20.8
32	68	6.5	15	11.1	22.4
34	66	5.5	14	12.07	24.2
36	64	9.4	24.2	13.2	26.4
38	62	17.4	33.2	13.53	27.01
40	60	22.2	40.3	26.24	52.5
42	58	25.5	57.23	31.20	72.42

From Table 2, the data recorded shows that when the percentage of the switching ON of the duty cycle decreases the charging times of the output USB will be faster in every 5% of the battery percentage. The duty cycle 42% ON recorded the longest charging times which is it takes 57.23 minutes for USB 1 and 72.42 minutes for USB 2 in order to complete 10% of charging percentages of the battery. The ideal duty cycle to ensure better-charging performance is 34% ON and 66% OFF of the PWM. Furthermore, 34% of the duty cycle of PWM were chosen for the hardware implementation of the system. This is to ensure the user of this project experience the better charging performance when they do the outdoor activities in which there is no power supply around. Figure 4. shows that the graph of duty cycle against charging speed between output USB.

**Figure 4.** The graph of duty cycle against charging speed between output USB.

4.2. Solar PV test

In this experiment, the same step has been taken from previous assessment. The result is obtained from this experiment in which the coding of the PWM duty cycle was changed from 30% to 42% ON. Thus, The coding was injected into the microcontroller and both outputs of the buck converter were manually measured using a digital multimeter. In this experiment, the full system of the photovoltaic was used. The results as in Table 3.

Table 3. The duty cycle and the recorded charging time of both output buck converter using Solar PV.

Duty Cycle (%)		Charging Times of Output USB 1 (min)		Charging times of Output USB 2 (min)	
ON	OFF	0-5%	0-10%	0-5%	12.15
30	70	5.48	11.34	6.25	12.17
32	68	5.12	10.09	5.49	15.51
34	66	7.13	14.21	7.37	14.45
36	64	9.37	21.56	7.45	22.33
38	62	9.53	20.33	11.1	27.20
40	60	10.4	21.14	13.2	32.53
42	58	12.5	27.35	14.2	12.15

From Table 3., the data recorded shows that when the percentage of the switching ON of the duty cycle decreases the charging times of the output USB will be faster in every 5% of the battery percentage. This pattern shown is the same as analysis in Table 2. The duty cycle 32% ON of the PWM is the fastest time taken to complete 5% of charging state. By this analysis, the ideal duty cycle to ensure better-charging performance is 32% ON and 34% percent OFF of the PWM. So this coding of ideal PWM duty cycle was chosen for the hardware implementation of the complete system. This analysis also to ensure the user of this project experience the better charging performance in the real-time implementation.

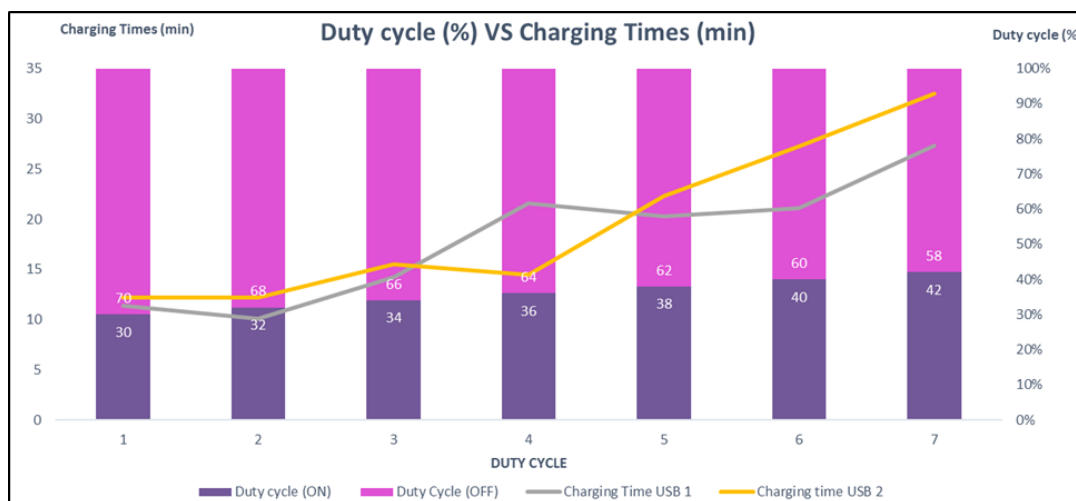
**Figure 5.** The graph of duty cycle against charging speed between output USB.

By considering that the PV performance test was conducted and it is shown that the real I-V and P-V characteristic of this solar panel as in Figure 6 (a) and Figure 6 (b).

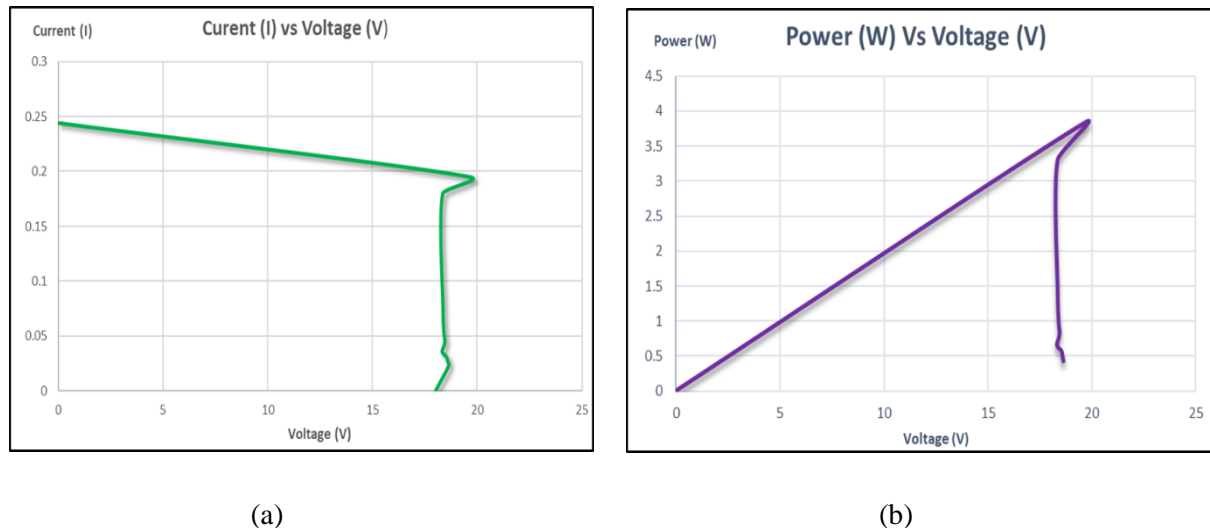

Figure 6. (a) I-V Curve of the PV Module (b) Generated Power versus Voltage.

The Figure 6. (a) shows the graph of the current-voltage (I-V) and Figure 6. (b) shows the graph of the power-voltage (P-V) characteristic of the PV module that has been used in this project. The power delivered by the solar cell is the product of the current and voltage from the 10W PV module. All the voltages from short-circuit to open-circuit conditions, the power curve above is obtained for a given radiation level. The combination of current and voltages for which the power reaches its maximum values. This solar I-V characteristic curves also can show us the different values of voltages and current for different levels of isolation and temperature and can shows the ability of this solar modules to convert sunlight into electricity. The Photovoltaic I-V characteristic curve also can provide the information needed for user to configure a solar power array so that it can operate as close as possible to its maximum peak power point.

5. Conclusion

The focus of this project is to develop a buck converter with a single input and produce multiple outputs in term of the power. The input voltage of this system initially was supplied using the laboratory power supply and will compare to the Real-time implementation of the PV system supply. Both results come out with the desired output as designed. Moreover, it also can be concluded that different duty cycle will affect the output of the buck converter and efficiency of the system. This analysis also has been shown in this chapter. Thus for the PV system to ensure the ability of the PV modules itself produce enough electricity to supply the system and to charge the battery storage.

Acknowledgement

The authors would like to express their gratitude to the Department of Electrical Engineering Technology, Faculty of Engineering Technology (FETech) and Research Management Innovation Centre (RMIC) of Universiti Malaysia Perlis for the allocation of grant incentives for publication.

References

- [1] D. G. Holmes and T. A. Lipo, Pulse Width Modulation for Power Converters. 2010.
- [2] Daniel W.Hart, Power Electronics. 2011.
- [3] M. Z. Aihсан, N. H. Baharudin, T. M. N. T. Mansur, R. B. Ali, L. S. Sing, and N. A. Rahman, "Design, Simulation and Implementation of a 300W 24V Power Converters for Magnetic

- Levitation Vertical Axis Wind Turbine System,” *Appl. Mech. Mater.*, vol. 679, no. August 2015, pp. 14–19, 2014.
- [4] N. I. Ahmad et al., “Development of Double Rotation Vertical Axis Generator with Double Rotation of Wind Turbine,” 2018 Int. Conf. Comput. Approach Smart Syst. Des. Appl. ICASSDA 2018, pp. 1–5, 2018.
- [5] M. Khudri Johari, M. Azim A Jalil, and M. Faizal Mohd Shariff, “Comparison of horizontal axis wind turbine (HAWT) and vertical axis wind turbine (VAWT),” *Int. J. Eng. Technol.*, vol. 7, no. 4.13, pp. 74–80, 2018.
- [6] N. B. Ahamad, M. Othman, J. C. Vasquez, J. M. Guerrero, and C. L. Su, “Optimal sizing and performance evaluation of a renewable energy based microgrid in future seaports,” *Proc. IEEE Int. Conf. Ind. Technol.*, vol. 2018–Febru, pp. 1043–1048, 2018.
- [7] A. N. Syafawati et al., “Forecasting the potential of solar energy harvest in Kangar,” *Proc. 2013 IEEE 7th Int. Power Eng. Optim. Conf. PEOCO 2013*, no. June, pp. 77–82, 2013.
- [8] M. Z. Aihsan, R. B. Ali, M. Othman, N. A. Rahman, and L. S. Sing, “An Improved Switching Strategy For Single Phase SPWM Inverter to Reduce Power Loss and Total Harmonic Distortion,” *Appl. Mech. Mater.*, vol. 793, pp. 172–176, 2015.
- [9] D. Angulo-Garcia, F. Angulo, G. Osorio, and G. Olivar, “Control of a DC-DC Buck Converter through Contraction Techniques,” *Energies*, vol. 11, no. 11, p. 3086, 2018.
- [10] C. A. Osaretin and F. O. Edeko, “Design and Implementation of a Solar Charge Controller with Variable Output,” *J. Electr. Electron. Eng. VOL*, vol. 12, no. November, pp. 40–50, 2015.
- [11] A. Mukhtaruddin, S. H. Syed Idris, M. Isa, M. M. Azizan, and B. Ismail., 2014. Neutral Conductor Size Selection for Balanced and Harmonic Infested Electrical System. *Int. J. Eng. Technol.*, vol. 6, no. 6, pp. 2650–2661
- [12] M. M. Garg, M. K. Pathak, and Y. V. Hote, “Effect of Non-Idealities on the Design and Performance of a DC-DC Buck Converter,” *J. Power Electron.*, vol. 16, no. 3, pp. 832–839, 2016.