

Diagnosics of Oil Filled Cable Terminations

¹MOHD RAFI ADZMAN, ¹MUZAMIR ISA, ¹BAHARUDDIN ISMAIL, ²MATTI LEHTONEN AND ²PETRI HYVONEN

School of Electrical System Engineering¹, KUKUM Malaysia.

Tel/Fax/Email: +604-9798429 / +604-9798304

mohdrafi@kukum.edu.my

Laboratory of Power System², TKK Finland.

Received : 14 January 2006 / Accepted : 22 November 2006
© Kolej Universiti Kejuruteraan Utara Malaysia 2006

ABSTRACT

Cable termination is one of the important components in the electrical power system. A failure of it can cause a long interruption, costly repair and loss of revenue. An existing oil filled cable termination such as rubber tube and porcelain type of cable termination require an observation and preventive maintenance in order to prevent an enormous electrical system failure in future. One of the defects of this type of oil filled cable termination is the lack of insulation oil inside it. The worst case if it becomes totally empty and at the same time there is no approach that can help to detect it. This paper presents the work carried out to find any possible method that can be used to detect a drying out of oil impregnated paper tape cable terminations. Furthermore, the diagnosis has to be used without destroying the terminations. Two diagnosis methods; infrared (IR) thermography and X-ray imaging are reviewed and the diagnosis result is presented. By comparison of two diagnosis method in this work, the X-ray imaging method is the best approach to observe and detect a drying out of paper tape oil impregnated cable terminations.

Keywords: IR Thermography, X-ray imaging, insulation and cable termination.

INTRODUCTION

The background of this work is a diagnosis of a Medium Voltage (MV) oil impregnated paper insulated cable terminations. In general, terminations are required when MV cables are connected to the overhead lines or other electrical apparatus such as transformer, bushing, capacitor bank, circuit breaker and so on. Cable termination is one of the important components in the electrical distribution power system. It is designed to possess the same integrity as their associated cables.

Normally, before the evolution of heat shrink and cold shrink cable terminations, porcelain type of termination as shown in Figure 1 and rubber tube type of termination were the two major types of cable termination used for impregnated paper insulated cables. This type of cable terminations are normally oil filled. One of the defects of

this type of cable termination is the lack of insulation oil inside it. In the worst case if it becomes totally empty and at the same time there is no approach that can help to detect it. This defect is probably due to the poor sealing, leakage and a local damage as a result of improper installation [1] [2]. Other possible reason for drying up is insulation oil penetration into the paper insulation and further into the conductor. The dried up of insulation oil inside the termination will lead to the abnormal heat distribution as well as abnormal voltage distribution in the termination itself and further will lead to a cable failure. Normally it will take time before the insulation oil is totally dried up.

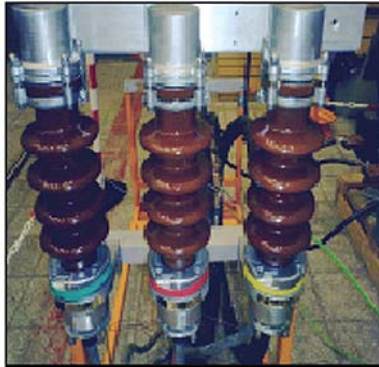

Figure 1. Example of oil filled porcelain type of termination.

The main purpose of doing a diagnostic in cable system including its accessories such as impregnated paper insulated oil filled cable termination is to predict failure before they occur. Those cable and accessories which are about to fail can be replaced provided that if we can detect them earlier, thereby reducing the incidence of electrical system failure, thus reducing the electricity outages.

EXPERIMENT METHODOLOGY

Two techniques are discussed in this section. Begin with infrared (IR) thermography and X- ray imaging.

Infrared Thermography

Infrared (IR) imaging technique is one of the diagnostic tools that we proposed to detect the dried up oil impregnated paper tape cable termination in this project. The purpose of this experiment was to observe the temperature distribution of cable termination by using the IR imaging camera. We want to observe the temperature characteristic at the termination which has different level of oil insulation.

During experiment, three unit of porcelain type of termination as shown in Figure 1 has been used. To identify whether there is a difference in temperature distribution due to

low level of oil insulation inside the cable termination, one of the insulation oil from the three units of the termination has been removed to half level and the other two was remained in full level. From Figure 1, the termination in the middle was the one that we removed its insulation oil to half level. The setup in the laboratory is shown as in Figure 2. It mainly consisted of 3-phase Paper Impregnated Lead Covered (PILC) cable with the porcelain type of termination at the end of the cable. Current to the PILC cable and its termination is supplied by a 415V, 50Hz 3-phase AC supply through a current transformer. In order to control the voltage and the current, 3-phase variac which was connected to the 3-phase main AC supply has been used. The current was measured by using 3 unit of Current Transformer (CTs) and measured signals were fed to the digital precision wattmeter.

The maximum AC current that was fed to the cable and its termination was 200A per phase. During the experiment, the cable and its termination were heated around 2 hours. A versatile IR imaging camera model 760 from Inframetrics was used for thermal imaging measurements. The IR camera observed the temperature at the termination continuously from beginning till the end of the experiment for the period of two hours.

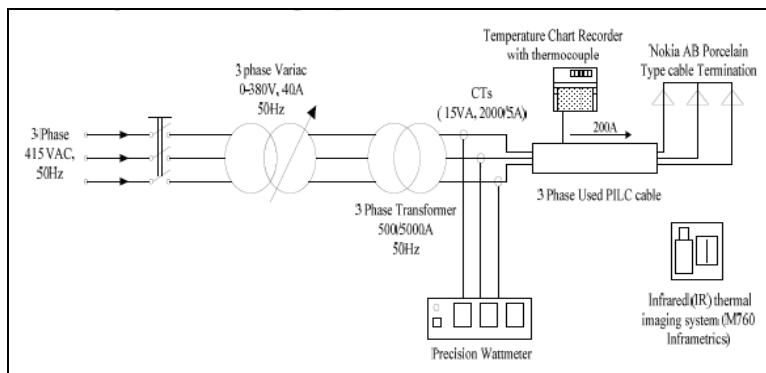

Figure 2. Schematic diagram of measuring temperature distribution in cable termination with the infrared (IR) digital camera.

X-ray Imaging

X-ray imaging is one of the latest and most advanced methods for Non Destructive Test (NDT) methodologies. Mostly X-ray has been used for decades in medical applications. Nowadays, its scope of services has been established for all kind of applications such as in aerospace, automotive, electrical, electronic, petrochemical, welding and also general inspection. The concept of digital X-ray imaging system configuration is shown in Figure 3. Based on Figure 3, it consists of X-ray source, image receptor, analogue to digital conversion, computer and display. The method is based on projected X-ray from the sample onto the detection screen such as photographic plate or special plastic sheet to create a shadow of internal structure of the sample.

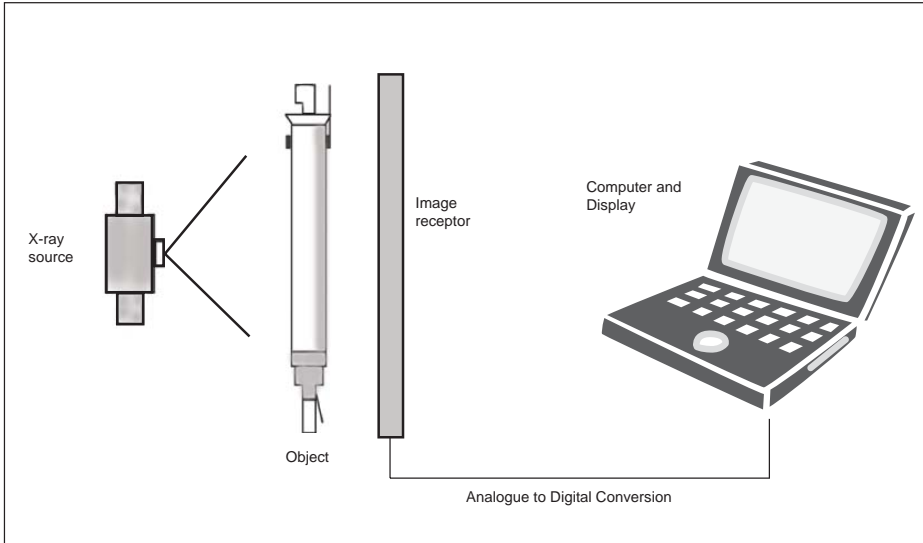

Figure 3. Example of digital X-ray imaging system configuration.

One of the advantages of this kind of advanced technology is portable with a special feature of low X-ray radiation and hence less dangerous to human and easy to handle [3]. By using this technique we can see the internal fault and from that diagnosis it is easy to make a decision for a proper action whether to replace or maintaining the termination

MEASUREMENT RESULT AND DISCUSSION

The measurement result are presented and discussed in this section. Begin with infrared (IR) thermography and then X-ray imaging.

Infrared Thermography

After carrying out the measurements for two hours the IR digital camera images were analyzed. The IR digital camera imaging result are shown in Figure 4.

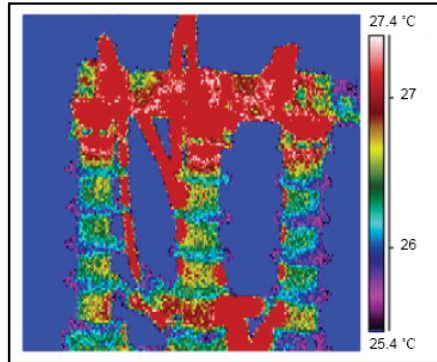

Figure 4. Thermal images of porcelain type of cable termination subjected to 200A, 50Hz for 120 minutes.

It can be seen that the middle porcelain termination having most of the area with yellowiest color compared with the other two terminations. Red color can be seen at the lower and upper part of the middle porcelain termination. Based on IR thermal image results, we can know that the middle porcelain termination having higher temperature than the other two terminations.

The unsatisfactory part from this experiment is that we could not see any separator mark of oil level showing a temperature difference between two levels for instant upper and lower part of termination. Most probably, this kind of fault can only be seen by using a high sensitivity and resolution infrared thermography camera.

The higher temperature at the upper part on each termination is due to of all area at the end caps of the terminations (see Figure 4) is a conductor. Meanwhile, the higher temperature at the lower part of the termination is probably due to the higher electrical field stress near the edge of the insulation screen of the cable. The experiments also focus on porcelain type of cable termination. Further investigation using IR camera measurements should be made to other type of oil filled cable termination such as rubber tube type of cable termination. The diagnosis result is expected to be different due to different material properties of the termination.

X-ray Imaging

The X-ray image of rubber tube cable termination was taken at several existing substations in Finland. From the X-ray image as shown in Figure 5(b), it can clearly be seen that the oil is always in horizontal position, even though the cable termination posture was not in vertical position. The X-ray image shows that the insulation oil inside the rubber tube type of termination is at the specified mark level. Based on the X-ray image we can make a decision that as long as the insulation oil inside the termination remains in full position, the termination is in good condition. Otherwise if there is some other internal defect that cause partial discharges in the cable termination system. In case of porcelain type of termination, it required higher quantity of X-ray to

produce a good image of shadows. This is because porcelain has higher density and it absorbed more X-rays than rubber.

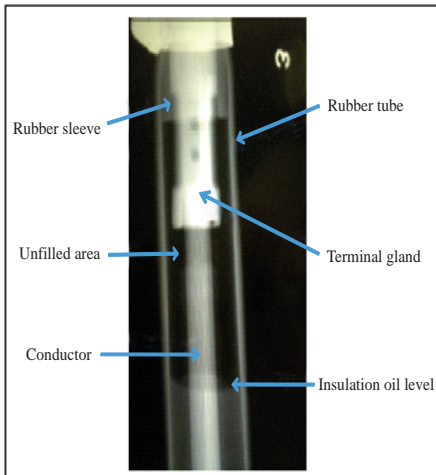

5(a)

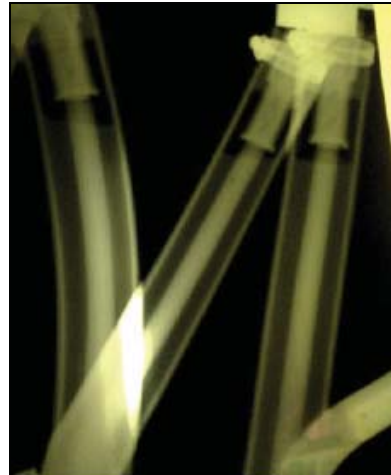

5(b)

Figure 5(a) and 5(b). X-ray image on the upper side of rubber tube type of termination.

CONCLUSION

In general, the investigation of external faults is much simpler than the internal faults. Admittedly, to analyze an internal fault like a drying out of paper tape cable termination is not an easy task and it is difficult to be analysed by common electrical test.

Based on the investigation, practice and experiment results with IR thermography diagnosis to the cable termination with low insulation oil level gave unsatisfactory result. This is probably due to the limitations of the infrared system such low resolution, unsuitable waveband and required good interpretation. In most cases the infrared technique is best for hunting the hot spot in cable system such as loose contact or connection of conductor.

The X-ray imaging diagnostic method seems to be the best approach to observe and detect a drying out of oil impregnated paper tape oil filled cable terminations. The X-ray images show clearly the level of insulation oil inside the rubber tube termination. From the X-ray image, we can make a fast decision on how the action to be taken for replacing or maintaining the termination before it can cause further damage and create a large damage to the cable network.

ACKNOWLEDGEMENTS

The project was realized in co-operation with laboratory of high voltage and power system, TKK, Finland; KUKUM, Malaysia; as well as Technical Research Centre (VTT) and Fortum, Finland. Thanks to them.

REFERENCES

1. Niancang Hou, (1998, August). The infrared thermography diagnostic technique of high voltage electrical equipment with internal faults, *IEEE Proceedings Power System Technology, Volume 1*: 110 – 115
2. Taylor, B., Morrison, G. and Welch D., (1997, September). Evaluating Medium Voltage Cable Splices and Termination, *IEEE Conference Paper on Petroleum and Chemical Industry Society*: 121 – 127
3. De Mello, D.R., Acioli, E. and Gois, N., (2004, November). *Location of internal faults in high voltage lines and distribution equipment*, Transmission and Distribution Conference and Exposition: Latin America, IEEE/PES: 28 - 28
4. Al-Kassir A. Rahman, Fernandez J., Tinaut F.V., Castro F., (Feb 2005). Thermographic study of energetic installations, *Applied Thermal Engineering, Elsevier Ltd, Volume 25*: 183-190,
5. Lundgaard L.E., Hansen, W., (June 1998). Acoustic method for quality control and in-service periodic monitoring of medium voltage cable terminations, Conference Record of the 1998 *IEEE International Symposium on Electrical Insulation, Volume 1*: 130 – 133
6. Raicevic N.B., (Aug 1999). *Electrical field and potential distribution at the cable termination*, International Conference on Electric Power Engineering (PowerTech):215