

PAPER • OPEN ACCESS

Synchronized cell balancing charging of supercapacitors using PI control

To cite this article: M.A Rashed *et al* 2020 *J. Phys.: Conf. Ser.* **1432** 012010

View the [article online](#) for updates and enhancements.

You may also like

- [Analysis of Energy Management Using PI Logic Controller Technique for Supercapacitor Applications](#)
M F Bahri, M A Aazmi, M I Fahmi et al.
- [Design and Analysis of EAST Predictive Control System for Hot Nitrogen Baking Process](#)
Duheng Fei, Lili Zhu and Wei Bao Li
- [Design of real time magnetic field compensation system based on fuzzy PI control algorithm for comagnetometer](#)
Chen Cheng Tang, Chang Liu, Caio A G Prado et al.



The Electrochemical Society
Advancing solid state & electrochemical science & technology



249th
ECS Meeting
May 24-28, 2026
Seattle, WA, US
Washington State
Convention Center

Spotlight Your Science

**Submission deadline:
December 5, 2025**

SUBMIT YOUR ABSTRACT

Synchronized cell balancing charging of supercapacitors using PI control

M.A Rashed¹, M I Fahmi*¹, M M Azizan¹, C L wai¹, L W Zhe¹, N F Rosle¹

¹Centre of Excellence for Renewable Energy, School of Electrical System Engineering, University Malaysia Perlis, 02600 Arau, Perlis, Malaysia.

Email: izfahmi@gmail.com.

Abstract. This paper covers the synchronized cell balancing charging of supercapacitors using pi control. The main objective of this project is to design a balanced circuit for supercapacitor and balance the voltage for each supercapacitor in series using pi control. This project aims to introduce a switch resistor design for a supercapacitor to balance the cell. Due to its low cost, easy to implement, and charge/discharge, the switch resistor design was chosen as the balanced circuit. The switch resistor design process was accomplished taking into account all the calculation for the design parameters. Using the pi control given to the circuit the stability and balancing in the voltage. The pi control design process was accomplished with the calculation for the design parameters.

1. Introduction

A supercapacitor (SCs) called ultracapacitors or electrochemical capacitors are needed for supercapacitors to increase reliability and extend their period of time [1]. Use high-expansion conductive materials and thin electrolytic dielectrics to capture many orders of magnitude greater than typical condensers [2], [3]. In doing so, supercapacitors square measure ready to achieve higher energy densities while maintaining typical capacitors characteristic high-power density [4]. Supercapacitor could, therefore, become an attractive power solution for a growing number of applications [5]–[7]. In low-power supercapacitor applications, the switched resistor circuit was a popular cell balancing scheme. Depending on the application situation, two classes of circuits are evaluated in the literature, active equalization circuit and passive equalization circuit [8]. While the efficiency is comparatively low, in low-power applications, passive equalization circuits are favoured wherever the system size and cost budgets are limited. In particular, the switched resistor circuit was a commonly used passive equalization circuit as it achieves a good interaction between performance and cost [9]. The active equalization method in low-power applications is not acceptable because of the complexity of the circuit, the difficulty of the control, the large size [10]. The feedback control system is a closed-loop control system. Closed-loop control systems are designed to achieve and maintain the desired output voltage by comparing it to the reference voltage using the PI controller for switch resistor [11]. The PI controller generates an error signal that is the difference between the switch resistor output voltage and the reference input. In industrial control systems, the Proportional-Integral-Derivative (PID) controller is widely used [12]–[14]. This system also can use in low power application for photovoltaic [15], [16] This paper designs a balanced circuit for supercapacitor using switch resistor, balance the voltage for each supercapacitor in series and implement the PI control to balance the circuit. The voltage balance in each cell by creating a design switch resistor with PI control and without PI control for the circuit, taking into account the voltage in each supercapacitors whether balance or not.



2. Methodology

2.1 Design Switch Resistor

In this study, the voltage in each supercapacitor approximately reaches to 16.2V, 15V, 14.4V, 13.8V because there will be 4 data using in this project in order to obtain all these output voltages from each supercapacitor. In this Table 1 shows the data, the voltage in each supercapacitor and the total of the output voltage.

Table 1. Data for output voltage.

Data	Voltage in each supercapacitors	Total output voltage
1	2.7V	16.2V
2	2.5V	15V
3	2.4V	14.4V
4	2.3V	13.8V

Figure 1 shows the circuit for the switch resistor. These circuit done in simulation which means is switch resistor. When the resistance has the same value in parallel with the cells, the cells with high voltage it will discharge through the external resistance (R_s) at a higher rate than the cells has a lower voltage

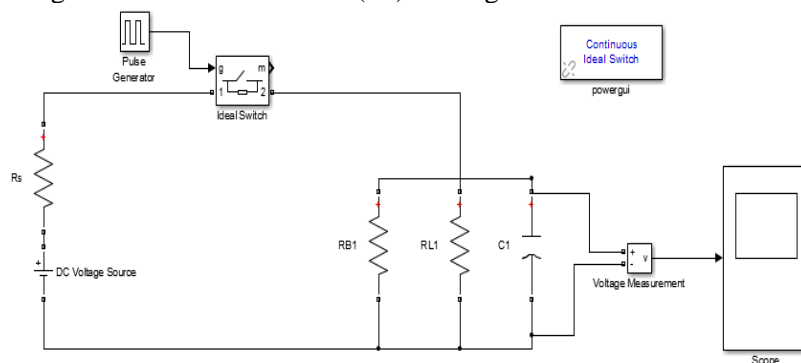

Figure 1. Circuit for Switch Resistor

2.2 Design PI Control

This is a feedback control system is a closed-loop control system is designed to achieve and maintain the required output voltage in the data 1, 2, 3, and 4. It will generate the error signal between the switch resistor output voltage and the reference input. Figure 2 shows the control used in the circuit. In this block diagram, there is a constant block to generate a real or complex constant value signal. Use this block to provide a constant signal input. Because it is different in the input and output so, will be error signal and that error signal will give to the controller and the controller will control the error signal so, the K_p and K_i will manipulate the output. The relational operator block used to compare the signal in the data 1, 2, 3, and 4 and generate the pulses. The repeating sequence used to generate the sawtooth wave at switching frequency which means is 25 kHz. First, need to increase the K_p until reaches a stable and consistent oscillation, this K_p called as ultimate gain K_u and the oscillations period as T_u . While increasing the K_u , the K_i remains zero. In 1.3 K_u the oscillations will be stable and consistent, and the period is 0.001 T_u as shown in Figure 3. Firstly, the step to do the calculation for the K_p and K_i , by increasing the value of K_u starting with 1 until reach to the value that will make the oscillations stable and consistent, so the value of K_u will be 1.3. Secondly, the step to do the calculation for the K_i , by finding the value for the T_u from the period in the oscillation stable in the previous Figure 3 which the value will be 0.001, the value of K_i by using the formula is 700. Then, the steady-state condition will happen in the required voltage that in each data 1, 2, 3, 4, and it will achieve and maintain the required output voltage in the data.

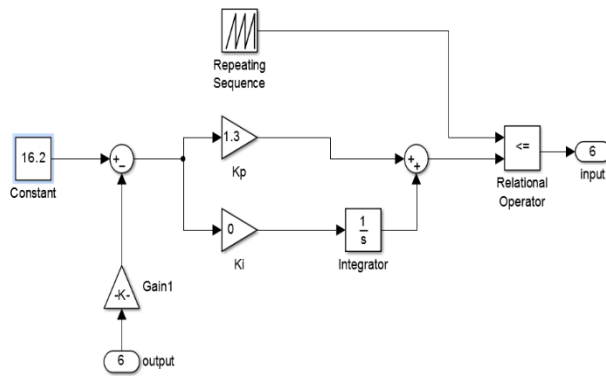

Figure 2. PI Control

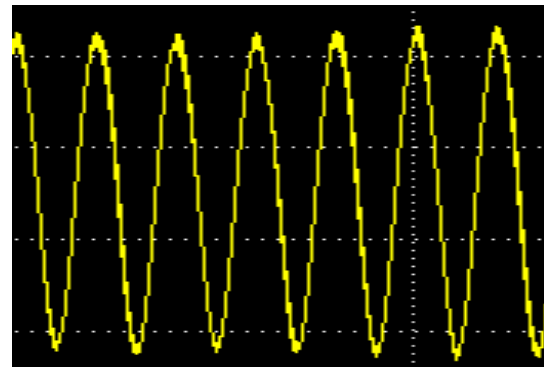

Figure 3. Oscillations with stable 1.3Ku, period 0.001Tu

By using the Ziegler- Nichols method there is a small calculation to calculate the values for Kp and Ki.

$$Kp = (0.45) (Ku) = 0.585 \tag{1}$$

$$Ki = \frac{(1.2)(0.45)(Ku)}{Tu} \tag{2}$$

2.3 Simulation

This is a feedback control system is a closed-loop control system is designed to achieve and maintain the required output voltage in the data 1, 2, 3, and 4. It will generate the error signal between the switch resistor output voltage and the reference input. Figure 2 shows the control used in the circuit. In this simulation there are two different results, the circuit before adding the PI control as shown in Figure 4 and the circuit after adding the PI control as shown in Figure 5. In this circuit there is a dc voltage source is connected to the internal resistance and to the ideal switch and the ideal switch is connected to the cells, there is 6 ideal switch connected to 6 cells, and there is 6 pulse generator is connected to 6 ideal switches. In this circuit there is a DC voltage source is connected to the internal resistance and to the ideal switch and the ideal switch is connected to the cells, there are 6 ideal switches connected to 6 cells, and the ideal switch is connected to the Pi controller. The pi controller will control the ideal switch and the circuit.

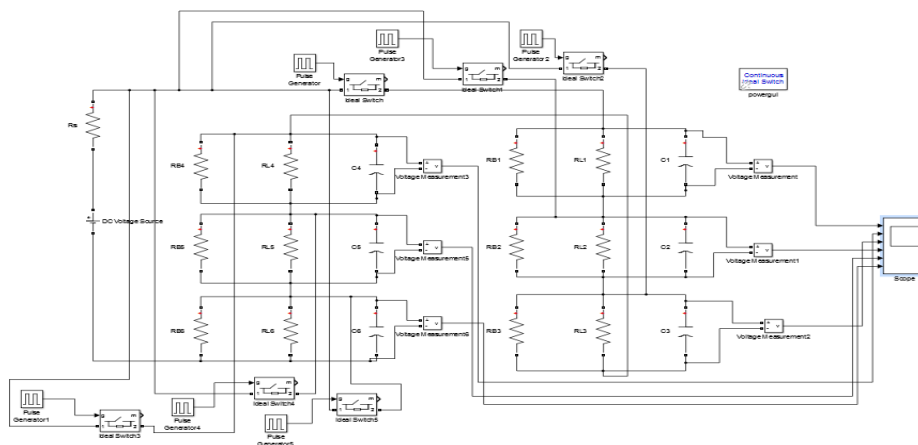

Figure 4. Circuit without Pi control

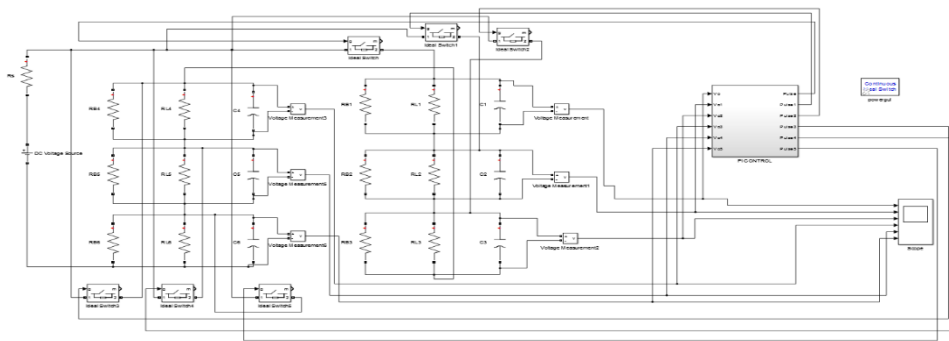

Figure 5. Circuit with Pi control

3. Result And Discussion

3.1. Result before adding pi control

The simulation result that is obtained for the 6 cells before adding the PI control as shown in Figure 6, Figure 7, Figure 8 and Figure 9 from data1, data2, data3, and data4 are using the same value that we assume before in Table 1 in order to get the balancing voltage which mean is all the value has the same voltage that across the supercapacitor. Table 2 and Table 3 lists the values of voltage for different data for different cases of study.

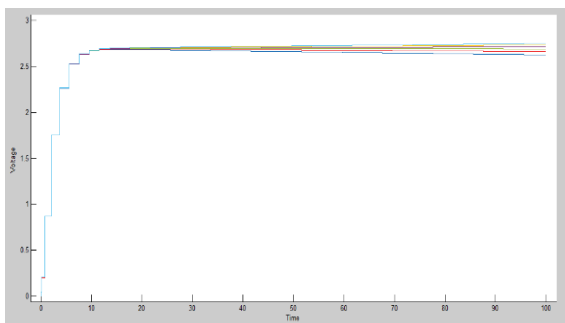

Figure 6. Result data 1

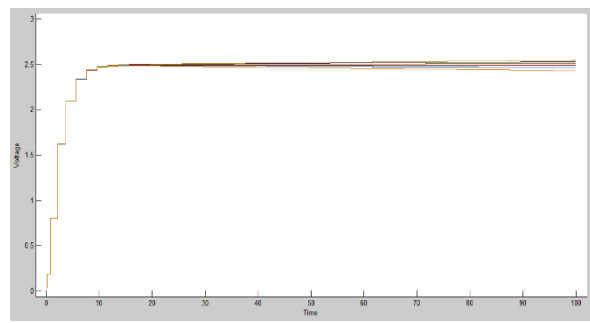

Figure 7. Result data 2

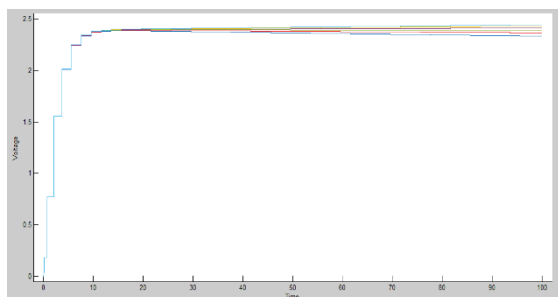

Figure 8. Result data 3

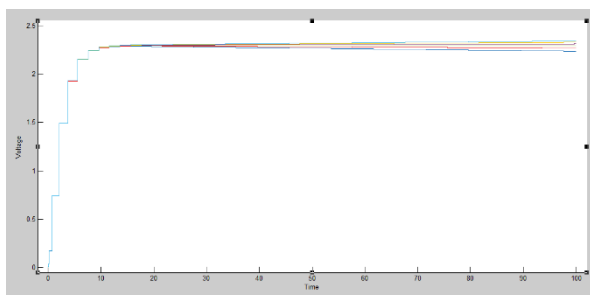

Figure 9. Result data 4

Table 2. Values of voltage for data 1 – data 4.

Supercapacitors	Data1	Data2	Data3	Data4
Cell 1	2.624V	2.429V	2.366V	2.238V
Cell 2	2.661V	2.464V	2.34V	2.268V
Cell 3	2.69V	2.491V	2.391V	2.291V
Cell 4	2.717V	2.512V	2.412V	2.312V
Cell 5	2.734V	2.534V	2.43V	2.33V
Cell 6	2.75V	2.543V	2.444V	2.342V

By comparing the results for data 1, 2, 3, and 4 from the simulation, the similarities between the data 1, 2, and 4 are cell 1 when the voltage dropped, the switch was off after reaching those values in data 1, 2, and 4. Except for data 3, cell 1 is a regular voltage which means that the voltage reaches the required 2.4V. For cell 2 in data 1, 2, and 4 are a regular voltage which means that the supercapacitors can get to the required voltage 2.7V for data 1, 2.5V for data 2, and 2.3 for data 3. For cell 3, all the data 1, 2, 3, and 4 reaches to the required voltage 2.7V for data 1, 2.5V for data 2, 2.4V for data 3, and 2.3V for data 4. For cells 4, 5, and 6, all data 1, 2, 3, and 4 reach higher than the required voltage because the switch is on, in this case, meaning that it still receives the voltage while charging the supercapacitors, while the switch should be off to prevent cells from receiving more voltage that could damage the supercapacitors.

3.2. Result after adding pi control

The simulation result that is obtained for the 6 cells after adding the PI control as shown in Figure 10, Figure 11, Figure 12 and Figure 13 from data1, data2, data3, and data4 are using the same value that we assume before in chapter II in order to get the balancing voltage which mean is all the value has the same voltage that across the supercapacitor.

From the results obtained from the simulation, there is no difference between the cells in the output voltage, that means is the voltage in each supercapacitor are equal, The results become equal cause there is no any varying among the cells, 1,2,3,4,5 and 6. Also, there is no any drop or increase in the voltage because it may damage the supercapacitors. The results from simulation for data 1, 2, 3, and 4 after adding the PI control was stable and balance in the output voltage for each supercapacitor in the cells and that cause there is a control in the circuit.

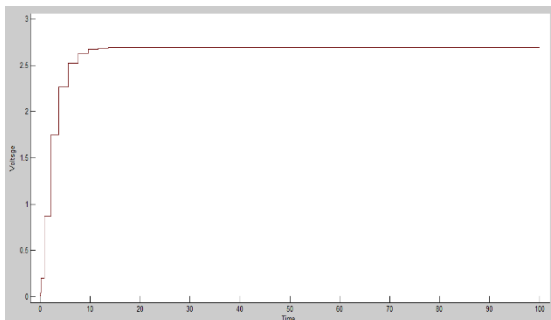

Figure 10. Result data 1

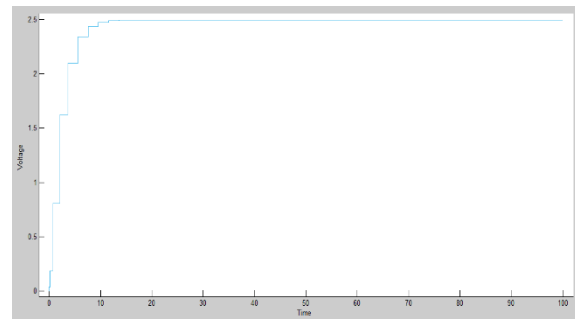

Figure 11. Result data 2

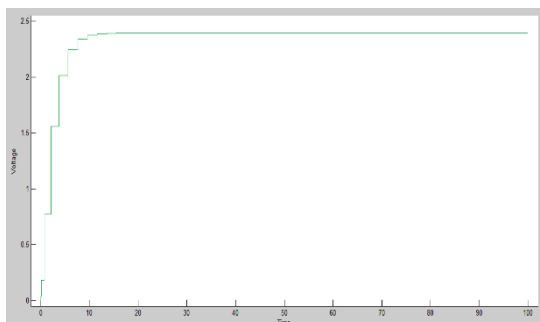

Figure 12. Result data 3

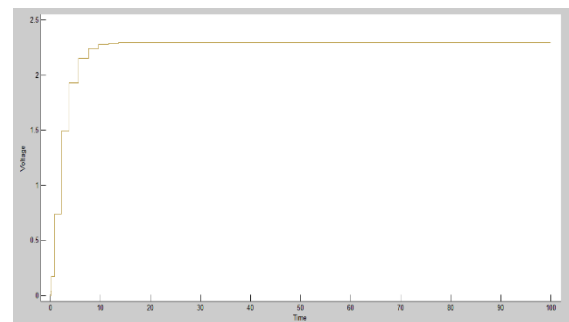

Figure 13. Result data 4

Table 3. Values of voltage for data 1 – data 4.

Supercapacitors	Data1	Data2	Data3	Data4
Cell 1	2.6943V	2.4947V	2.3949V	2.2951V
Cell 2	2.6943V	2.4947V	2.3949V	2.2951V
Cell 3	2.6943V	2.4947V	2.3949V	2.2951V
Cell 4	2.6943V	2.4947V	2.3949V	2.2951V
Cell 5	2.6943V	2.4947V	2.3949V	2.2951V
Cell 6	2.6943V	2.4947V	2.3949V	2.2951V

4. Conclusion

Generally, the use of balancing circuits in supercapacitors serial connection is compulsory. Balancing voltage on the cells extend the lifetime of the supercapacitors. There are two different results in the simulation, before adding PI control and after adding PI control. From the graph the results that before adding the PI control was not stable and did not reach to the required voltage cause there is decrease or increase in the voltage, In contrast, the results for after adding the PI control was stable, arrange, equal, and reach to the required voltage. And the steady-state condition happens when the charge reaches the required voltage in data 1, 2, 3, and 4.

Acknowledgements

This project was supported by *Centre of Excellence for Renewable Energy (CERE)*, School of Electrical System Engineering, University Malaysia Perlis (UniMAP).

References

- [1] P. Sharma and T. S. Bhatti, "A review on electrochemical double-layer capacitors," *Energy Conversion and Management*, vol. 51, no. 12, pp. 2901–2912, 2010.
- [2] M. Yassine and D. Fabris, "Performance of commercially available supercapacitors," *Energies*, vol. 10, no. 9, 2017.
- [3] H. F. Liew, R. A. Rahim, M. Isa, B. Ismail, and S. I. S. Hassan, "Analysis of batteries or supercapacitor as energy storage device for a sound energy harvester system," *IEEJ Transactions on Electrical and Electronic Engineering*, vol. 13, no. 12, pp. 1699–1708, Dec. 2018.
- [4] I. Jiya, N. Gurusinghe, and R. Gouws, "Electrical Circuit Modelling of Double Layer Capacitors for Power Electronics and Energy Storage Applications: A Review," *Electronics*, vol. 7, no. 11, p. 268, 2018.
- [5] L. X. Zhang Wenliang, Qiu Ming, "Application of energy storage technologies in power grids," *Power System Technology*, vol. 32 (7), pp. 1–9, 2008.
- [6] H. F. Liew, A. R. Rosemizi, M. Isa, B. Ismail, and S. I. S. Hassan, "Development of step-up transformer for low current and low power sound energy harvesting system," in *AIP Conference Proceedings*, 2018, vol. 2030, no. 1, p. 020123.
- [7] L. H. Fang, R. Bin Abd Rahim, M. Isa, S. I. Syed Hassan, and B. Bin Ismail, "The Design of Operational Amplifier for Low Voltage and Low Current Sound Energy Harvesting System," *IOP Conference Series: Materials Science and Engineering*, vol. 318, no. 1, p. 012035, Mar. 2018.
- [8] M. Uno and K. Tanaka, "Single-Switch Multioutput Charger Using Voltage Multiplier for Series-Connected Lithium-Ion Battery/Supercapacitor Equalization," *IEEE Transactions on Industrial Electronics*, vol. 60, no. 8, pp. 3227–3239, Aug. 2013.
- [9] D. Linzen, S. Buller, E. Karden, and R. W. De Doncker, "Analysis and evaluation of charge balancing circuits on performance, reliability and lifetime of supercapacitor systems," in *38th IAS Annual Meeting on Conference Record of the Industry Applications Conference, 2003.*, vol. 3, pp. 1589–1595.
- [10] B. Lindemark, "Individual cell voltage equalizers (ICE) for reliable battery performance," in *[Proceedings] Thirteenth International Telecommunications Energy Conference - INTELEC 91*, pp. 196–201.
- [11] C. Lu, G. Zhang, C. Du, and J. Cheng, "Design of closed-loop feedback control system for mini greenhouse illumination based on PWM," in *Proceedings - 2017 32nd Youth Academic Annual*

- Conference of Chinese Association of Automation, YAC 2017*, 2017, pp. 541–543.
- [12] T. C. A. Ajoy, S. Salimin, and R. Aziz, “Application of PI Current Controller in Single Phase Inverter System Connected to Non Linear Load,” in *IOP Conference Series: Materials Science and Engineering*, 2017, vol. 226, no. 1.
- [13] J. He and X. Zhang, “Comparison of the back-stepping and PID control of the three-phase inverter with fully consideration of implementation cost and performance,” *Chinese Journal of Electrical Engineering*, vol. 4, no. 2, pp. 82–89, 2019.
- [14] L. W. Zhe, M. I. Bin Yusoff, M. I. Misrun, A. B. Abdul Razak, S. Ibrahim, and N. S. B. Zhubir, “Investigation of Solar Panel Performance Based on Different Wind Velocity Using ANSYS Software,” *Indonesian Journal of Electrical Engineering and Computer Science*, vol. 1, no. 3, p. 456, Mar. 2016.
- [15] L. W. Zhe, Y. M. Irwan, M. Irwanto, M. Isa, A. R. Amelia, and I. Safwati, “Temperature Distribution of Three-Dimensional Photovoltaic Panel by Using Finite Element Simulation,” *International Journal on Advanced Science, Engineering and Information Technology*, vol. 6, no. 5, p. 607, Oct. 2016.
- [16] A. R. Amelia *et al.*, “Cooling on Photovoltaic Panel Using Forced Air Convection Induced by DC Fan,” *International Journal of Electrical and Computer Engineering (IJECE)*, vol. 6, no. 2, pp. 526–534, Apr. 2016.