



**Application of D-STATCOM to Mitigate High Inrush
Current During Start-Up of Three-Phase Induction
Motor**

by

**Ayob Nazmy Bin Nanyan
(1432221148)**

A dissertation submitted in partial fulfillment of the requirements for the
degree of Master of Science (Electrical Power Engineering)

**School of Electrical System Engineering
UNIVERSITI MALAYSIA PERLIS**

2014

ACKNOWLEDGMENT

Alhamdulillah and thanks to Almighty Allah S.W.T for giving me such ability and time to have completed this research. I would like to take this opportunity to express my profound sense of gratitude and respect to all those who helped me throughout the duration of this research.

In the first place, acknowledgement goes to my supervisor, Dr. Muhammad Mokhzaini Bin Azizan and my co-supervisor Mr. Ahmad Muhyiddin bin Yusof and other lecturers who guided me to complete this research as well as provide great ideas and technique to write a thesis. In addition, heartfelt thanks to my wife lovely wife Nurul Izza Mohd Nor and my son Muhammad Adam Izhan who had given moral support to me without hesitatingly. Not to forget, great appreciation goes to the Power System Laboratory technicians that help me from time to time during the simulation software.

Lastly, sincere appreciation and deepest thanks to all my friends who gave me moral support throughout this semester. Only with their love and encouragement made this thesis possible. To them I dedicate this thesis.

TABLE OF CONTENTS

	PAGES
DECLARATION OF THESIS	i
ACKNOWLEDGMENT	ii
LIST OF TABLES	vi
LIST OF FIGURES	vii
LIST OF ABBREVIATIONS	ix
ABSTRAK	x
ABSTRACT	xi
CHAPTER 1	1
INTRODUCTION	1
1.1 Overview	1
1.2 Objective of Research	2
1.3 Problem Statement	3
1.4 Scope of Research	3
1.5 Significant of Research	4
1.6 Thesis Outlines	4
CHAPTER 2	6
2.1 Introduction	6
2.2 Background of Induction Motor	6
2.2.1 Equivalent Circuit of an Induction Motor	7
2.2.2 Formula to Calculate Inrush Current	8
2.3 High Current during Start up Induction Motor	10
2.4 Effect of High Starting Current	12
2.5 Motor Standards on motor Inrush Current	13
2.6 Starting Method of Induction Motor	14
2.6.1 Full-Voltage Starting	15
2.6.2 Reduced-Voltage Starting	15
2.6.3 Conventional Starters	16

2.6.4	Power Electronic Starter	23
2.7	Thesis Contribution	26
2.7.1	Distribution Static Compensator (D-STATCOM)	26
2.7.2	Basic Operation of D-STATCOM	27
2.8	Application of D-STATCOM to Mitigate Inrush Current of Three-Phase Induction Motor	30
2.8.1	Principle of Reactive Current Control	30
2.8.2	Voltage Source Converter (VSC)	31
2.9	Trend in D-STATCOM Research Work	31
CHAPTER 3		34
3.1	Introduction	34
3.2	Flow of Research	34
3.3	Voltage Sag of Power System	36
3.4	Selection Power Electronic Device of VSC	37
3.5	PWM in Three-Phase Voltage Source Inverters	39
3.6	Power System Configuration & D-STATCOM Parameters	40
3.7	Flow Chart	42
3.8	Control of Proposed D-STATCOM	43
3.9	Control Method	45
3.9.1	Extraction the Positive Component	46
3.9.2	Application of 'dq' Controllers	47
3.9.3	DC Voltage Controller	48
3.10	Reactive Power Controller	48
3.11	Design of the 6-pulse D-STATCOM	49
3.11.1	Determine phase-shift angle	50
3.11.2	The harmonic content in this alternating voltage	51
3.11.3	Inverter Design	51
3.11.4	DC Bus Voltage	52

3.11.5	Capacitor Sizing	52
3.11.6	Transformer Configuration	53
3.12	PSCAD/EMTDC Tool	54
3.13	PSCAD/EMTDC Modelling	55
3.13.1	AC Power System	55
3.13.2	Transformer	55
3.13.3	Three-phase squirrel-cage induction motor	56
3.14	PSCAD/EMTDC Controller Configuration	56
3.14.1	Carrier Signal Generation	57
3.14.2	Sine Wave Signal Generation	58
3.14.3	Firing Pulse Generation Module	59
3.15	PSCAD Soft Starter Simulation	60
CHAPTER 4		62
4.1	Introduction	62
4.2	Setting of D-STATCOM Parameters	63
4.3	Result and Analysis	64
4.3.1	Direct Start-up (without D-STATCOM)	64
4.3.2	Induction Motor Start-up with D-STATCOM	65
4.4	Soft starter simulation result	73
4.5	Comparison inrush current during start-up induction motor between D-STATCOM and Soft starter	76
CHAPTER 5		78
5.1	Introduction	78
5.2	Conclusion	78
5.3	Future Work	80
5.3.1	Increase the number of induction machines	80
5.3.2	The Multi-stage of the D-STATCOM	80
REFERENCES		82
APPENDIX A		85
APPENDIX B		87

LIST OF TABLES

NUMBER	PAGES
2.1: Motor Performance (Madu Thirugnanasambandamoothy et al. 2011)	14
2.2: Different types of induction motor starters (Piyush S.Patil et al. 2009)	17
2.3: The comparison of the motor starting method	22
4.1: System Parameters used in simulation	63

© This item is protected by original copyright

LIST OF FIGURES

NUMBER	PAGES
2.1: The equivalent circuit of a transformer to model an induction motor	7
2.2: Induction machine per phase equivalent circuit (M.Thirugnanasambandamoorthy et.al 2011)	9
2.3: Inrush Current during starting induction motor	11
2.4: Direct Online Starter	18
2.5: Star-Delta Starter Connection	20
2.6: Auto-transformer Starter Connection	22
2.7: Thyristors soft starter (Li, et al. 2012)	25
2.8: Schematic of D-STATCOM as a custom power controller (Patil et al.2009)	28
2.9: Operation of D-STATCOM (Alpesh Mahyavanshi,et al. 2012)	29
2.10: Schematic of the autonomous power system (Ambarnath Banerji et al. 2012)	32
3.1: The flow of overall stage in this research.	35
3.2: Equivalent circuit for induction motor starting (Rahmat-Allah Hooshmand et al.)	36
3.3: Voltage sag magnitude and duration (L.S. Patil et al. 2009)	37
3.4: The power electronic components available in PSCAD/EMTDC	38
3.5: PWM illustration Sine-triangle, pulse-width-modulated control waveforms	40
3.6: Schematic of the power system using PSCAD/EMTDC	40
3.7: Flow chart process of inrush current mitigation strategy	42
3.8: The proposed of D-STATCOM in the power system	43
3.9: The proposed 6-pulse D-STATCOM configuration with the IGBT's used as power devices	50
3.10: Modelling of inverter	51

3.11: PSCAD/EMTDC equivalent power system model	55
3.12: Reactive power Control Loop	57
3.13: Generation of reference sine wave	58
3.14: Generating PWM Carrier Signal Model	59
3.15: Generating firing pulses of IGBT valve module	59
3.16: PSCAD Soft Starter	60
3.17: Soft starter firing controls	61
4.1: PSCAD circuit simulation of three-phase induction motor with direct start	64
4.2: Inrush current exists during direct starting of induction motor	65
4.3: D-STATCOM connected into the circuit	66
4.4: High inrush current occur in phase A (I_a) without connected with the D-STATCOM	67
4.5: High inrush current occur in each phase (I_a , I_b , and I_c) without connected with the D-STATCOM	68
4.6: Starting current (I_a) of induction motor with D-STATCOM connected to PCC	69
4.7: Starting current (I_a , I_b and I_c) of induction motor with D- STATCOM	70
4.8: Mitigation Starting Current with D-STATCOM	71
4.9: Mitigation of inrush current by D-STATCOM for all phase currents	71
4.10: A comparison of inrush current during starting induction motor with D-STATCOM and without D-STATCOM (direct start up)	73
4.11: Inrush Current without Soft starter (direct start up)	74
4.12: An inrush current when starting induction motor using Soft starter	75
4.13: A comparison of inrush current when starting induction motor by using Soft starter and direct start (without Soft starter)	76
4.14: A comparison of inrush current when starting induction motor using Soft starter and the D-STATCOM	77
5.1: The proposal of multi-stage D-STACOM connected with multi loads	81

LIST OF ABBREVIATIONS

AAG	Autonomous Asynchronous Generator
AC	Alternating current
API	American Petroleum Institute
DC	Direct Current
D-STATCOM	Distribution Static Compensator
EMF	Electromagnetic Field
EMTDC	Electromagnetic Transient in DC
GTO	Gate Turn-Off
HP	Horse Power
IEC	International Electro-technical Commissions
IGBT	Insulated Bipolar junction Transistors
KCL	Kirchhoff's current law
KVL	Kirchhoff's voltage law
kW	Kilowatt
NEMA	National Electrical Manufactured Associations
PCC	Point of common coupling
PLL	Phase locked loop
PSCAD	Power System Computer Aided Design
PWM	Pulse Width Modulation
RMS	Root mean square
RPM	Revolution per minute
SCR	Silicon Controlled Rectifier
VSC	Voltage Source Converter

Penggunaan Pengagihan Pemampat Statik Bagi Mengurangkan Arus Permulaan Tinggi Semasa Memulakan Motor Tiga Fasa

ABSTRAK

Tesis ini menerangkan pengaplikasian Pengagihan Pemampat Statik (D-STATCOM) untuk mengurangkan arus permulaan yang tinggi semasa motor tiga fasa dihidupkan. Arus permulaan yang tinggi wujud semasa menghidupkan motor dan boleh mencecah dari 6 sehingga 7 kali ganda daripada arus motor. Arus yang tinggi ini boleh memberi kesan pada motor itu sendiri terutamanya kepanasan melampau serta mengurangkan jangka hayat motor. Selain itu, arus yang tinggi semasa permulaan motor boleh menyebabkan bekalan kuasa utama mengalami kejatuhan mendadak dan memberi kesan pada perkakasan elektrik yang lain yang menggunakan talian yang sama. Tujuan utama tesis ini adalah untuk mendemostrasikan keupayaan D-STATCOM untuk mengurangkan arus permulaan yang tinggi semasa menghidupkan motor tiga fasa. Litar pengawal D-STATCOM ini telah disimulasikan dengan menggunakan perisian Rekebentuk Terbantukan Komputer Sistem Kuasa (PSCAD/EMTDC). Metodologi kajian ini ialah merekabentuk litar D-STATCOM yang terdiri daripada litar penukar voltan (VSC) sebagai litar utama. Litar VSC ini berfungsi untuk menukar voltan arus ulang alik ke voltan arus terus. Seterusnya voltan ini sekali lagi akan ditukarkan daripada voltan arus terus ke voltan arus ulang alik dan seterusnya voltan dihantar ke talian tiga fasa. Litar ini berkeupayaan menyerap dan menyuntik kuasa aktif dan kuasa reaktif sistem kuasa dengan cara mengawal magnitude voltan keluaran litar VSC ini. Untuk membandingkan keupayaan D-STATCOM ini, litar pemula lembut (*Soft starter*) telah dibangunkan. Litar *Soft starter* ini dikawal oleh 6 *thyristor*. Terdapat tiga kaedah yang digunakan iaitu memulakan motor elektrik iaitu secara terus, memulakan motor elektrik dengan menyambungkan litar D-STATCOM dan akhir sekali menghidupkan motor elektrik dengan menyambungkan litar *Soft starter*. Nilai bacaan arus permulaan motor telah diambil untuk tempoh sehingga 30 millisaat dan hasil keputusan telah dibandingkan antara ketiga-tiga kaedah tersebut. Analisa menunjukkan D-STATCOM telah mengurangkan arus permulaan motor elektrik semasa motor dihidupkan iaitu sehingga 74% jika dibandingkan dengan pemula secara terus dan bacaan tertinggi arus yang dicatatkan ialah 164 Ampere manakala bacaan tertinggi pemula terus ialah 637 Ampere. D-STATCOM ini dibandingkan pula dengan *Soft starter* untuk membandingkan keupayaan merendahkan arus permulaan motor semasa dihidupkan. Analisis menunjukkan D-STATCOM mempunyai keupayaan lebih tinggi iaitu 54.3% daripada *Soft starter*. Oleh itu, dengan hasil kajian ini menunjukkan bahawa D-STATCOM berkeupayaan lebih tinggi dalam mengurangkan arus permulaan motor dengan lebih baik jika dibandingkan dengan *Soft starter*.

Application of D-STATCOM to Mitigate Inrush Current during Start-up of Three Phase Induction Motor

ABSTRACT

This thesis presents the application of Distribution Static Compensator (D-STATCOM) to mitigate inrush current during start up three phase induction motor. Three phase induction motor draws high current during starting period and will from 6 to 7 times of the rated current of the motor. The effect of high starting current will cause severe damage to motor itself, especially overheating and making motor life expectancy short. In addition, the high starting current will cause the voltage of the power supply rapid drop and affect other devices' running in the same power line. The purpose of this thesis is to demonstrate that a D-STATCOM is capable to mitigate inrush starting current during start up induction motor. The controller circuit of D-STATCOM has been simulated by using Power System Computer Aided Design (PSCAD/EMTDC) software. The research methodology of this project is to design D-STATCOM circuit which consists of Voltage Source Converter as a main circuit. The function of this circuit is to convert AC to DC and then invert DC to AC before transmit to the three-phase power line. The circuit's has a capability to absorb and inject the reactive and active of the power system which is to control the magnitude of the VSC output voltage. To compare the capability of the D-STATCOM, a Soft starter is developed. The Soft starter circuit is controlled by six thyristors. There were three methods which can be used such as starting the induction motor with direct start-up, starting the induction motor by connecting with the D-STACOM and starting the induction motor with Soft starter. The starting currents of these three methods were observed up to 30 milliseconds and compared. The analysis result shows that the D-STATCOM had mitigated inrush current during start-up induction motor up to 74% higher compared to direct start-up and 164 Ampere is the highest inrush current recorded while direct start-up was 637 Ampere recorded. The D-STATCOM was compared with Soft starter to determine the ability of reducing inrush current during start-up induction motor. The result shows that the D-STATCOM had mitigated of 54.3% higher inrush current compared with Soft starter. Hence, the conclusion of this research is the D-STATCOM has a higher capability to reduce inrush current during start up the induction motor compared with Soft starter.

CHAPTER 1

INTRODUCTION

1.1 Overview

Inrush current explained very simply is the current drawn by a piece of electrically operated equipment when power is first applied. It can occur with Alternating Current (AC) or Direct Current (DC) powered equipment, and can happen even with low supply voltages. Three-phase induction motor has wide application in the industry control and electric drive system. The starting current or inrush current will reach six to eight times of the rated current when a motor is started across the line and also high torque during start up (Ghodhbani et al. 2010). The starting current will cause the voltage of the power supply to rapidly drop and affect other devices' running at the same power line. Meanwhile the line starting will cause severe damage to motor itself such as overheating and others. Various motor starters were introduced to overcome the problem. There are two types of motor starters which are conventional starters and power electronic drives. The conventional starters are Direct Online starter, Star- Delta starter, and Auto-transformer starter. The power electronic drives starters are Soft Starter, frequency inverter and matrix converter. In the recent years, power electronic drives Soft starter is widely used in industries because the capability of Soft Starter provides a low inrush current at start thus minimizing maintenance cost when compared to conventional starters and another power electronic starter. For application where speed control is required, the best and only option would be the frequency inverter.

This research is focused to develop the power electronic drive starter with different method by using Distribution Static Compensator (D-STATCOM) in order to provide a low inrush current during start up three-phase induction motor and finally produce a new option of power electronic drive starters for low voltage induction motor. This research collaboration with Engineering Service Department, Kilang Gula Felda Perlis Berhad (KGFPB), Perlis. The company's provided the specification data and types of motor that were used in their factory. The three-phase motor with Soft Starter operating has been chosen as reference motor to this research. The motor specification is a three-phase squirrel-cage induction motor manufactured by TECO with rated 100 horse power (HP), 415 V, 2 poles, and 3000 revolution per minute (rpm).

1.2 Objective of Research

The aim of this research is to design the D-STATCOM as a new power electronic drive starter and the specific objectives are;

- a) To determine the inrush current during start -up of the three phase induction motor.
- b) To compare magnitude current during start-up and steady state of induction motor between direct start-up, D-STATCOM and soft-starter.
- c) To propose retarding method of inrush current during start -up of the three-phases induction motor using D-STATCOM.

1.3 Problem Statement

With the rapid growth of technology and for the future, researchers focus more to power electronic drives development. The electromechanical starters have been used nearly since the invention of induction machine itself. The significant of power electronic drives is that it can provide low inrush current during start-up the motor thus minimizing maintenance cost when compared to electromechanical starters. However, the most popular power electronic drives as starter and widely used in industries is soft starter discussed in Chia-Chou et al.(2009). From the previous researchers, some of the soft starter can only be used in the low voltage motor, accompany secondary inrush current, impact velocity and torque shock and others. D-STATCOM is a flexible because it can operate either in the voltage or current mode. D-STATCOM compensated load can draw a perfectly balanced current from AC system, even when the supply is unbalanced or distorted.

1.4 Scope of Research

The specific scopes of research are to control D-STATCOM voltage to limit inrush current motor, limiting high starting current or inrush current during start-up of induction motor using D-STATCOM. In addition, this research will use three-phase low voltage squirrel-cage induction motor, 100hp, 415V, 50Hz, 2 poles and 3000 rpm with full load current is 122 A. The current of this motor is according to International Electro-technical Commissions (IEC) 60034-12.

1.5 Significant of Research

This research is focusing to apply the D-STATCOM for mitigation of inrush current during start-up induction motor. D-STATCOM has been widely used to solve power quality problem in distribution or transmission systems such as voltage dip, voltage swell and others. D-STATCOM is chosen to be applied in this research as there is no power electronic device starter that has used D-STATCOM as a motor starter to date. In this research, the application of D-STATCOM will be applied to control voltage and current in order to minimize the inrush current during start-up of the induction motor. Therefore, the application of D-STATCOM to mitigate inrush current will produce a new technique and option for the motor starters that are based on power electronic devices in the market and for future technology.

1.6 Thesis Outlines

This thesis will highlight the design of D-STATCOM as devices that mitigate an inrush current during start-up of induction motor. This is based on the literature review studies of D-STATCOM to date. The D-STATCOM consist the voltage source converter (VSC) as a controller of injecting and absorbing reactive power. The D-STATCOM has implemented with the proposed control scheme as a motor starter and the results have compared with soft starter using the same motor parameters.

Chapter 1 presents an introduction of research which is covered objectives of research, problem statement, scope and significant of research.

Chapter 2 presents a detailed discussion of the available literature on the characteristic of induction motor such as inrush current during start-up motor and

harmonic. Besides that, this chapter provides reviews on the conventional motor starters and also power electronic based devices motor starter such as soft starter and others.

Chapter 3 describes the method of research and designing the controller of D-STATCOM by using Power System Computer Aided Design (PSCAD/EMTDC) software. The design consists of the selection of power electronic devices, voltage source converter circuit and control scheme of power electronic devices.

Chapter 4 presents the simulation results of proposed D-STATCOM for controlling the inrush current. The results of optimization are summarised and compared with the soft starter.

Finally, Chapter 5 gives the conclusions of the thesis and the suggestion for further work as an extension of this study.

CHAPTER 2

LITERATURE REVIEW

2.1 Introduction

This research has reviewed various journals and papers that have been done by previous researchers. The conventional starters and power electronic starters have been reviewed mainly the advantages and disadvantages. Therefore, in order to determine which starting method is the best and most suitable for a particular application, an investigation is made to access the various starting characteristics in term of voltage, starting current , starting torque, the cost of installation, the maintenance cost and its payback period.

2.2 Background of Induction Motor

Induction motor has two types; one is called a squirrel-cage rotor while the other is wound rotor. A squirrel-cage induction motor rotor consist of a series of conducting bars laid into slots carved in the face of the rotor and shorted at either end by large shorting rings. This design is referred to as a squirrel-cage rotor because the conductors, if examined by themselves , would look like one of the exercise wheels that squirrels run on (J.Chapman,1991). However, wound rotor has higher maintenance cost, larger in size and its more expensive than a squirrel-cage induction motor making the squirrel-cage induction motor a preferred choice. Additionally, the squirrel-cage induction motor

is more popular and widely used in industry because it has a high efficiency up to 95%. Therefore, the starting characteristic in this research is based on the squirrel-cage induction motor.

2.2.1 Equivalent Circuit of an Induction Motor

An induction motor relies for its operation on the induction of voltages and currents in its rotor circuit from the stator circuit (transformer action). Because the induction of voltages and currents in the rotor circuit of an induction motor is essentially a transformer operation, the equivalent circuit of an induction motor will turn out to be very similar to the equivalent circuit of a transformer. An induction motor is called a singly excited machine (as opposed to a double excited synchronous machine), since power is supplied to only the stator circuit because an induction motor does not have an independent field circuit, its model will not contain an internal voltage source such as the internal integrated voltage E_a in a synchronous machine.

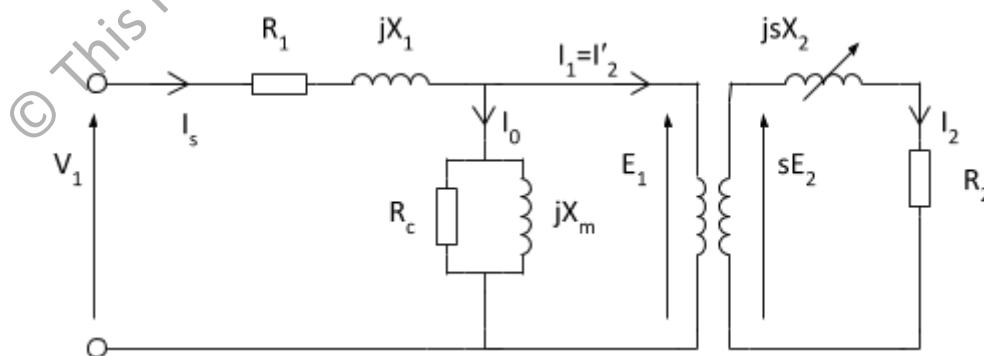

Figure 2.1: The equivalent circuit of a transformer to model an induction motor

Figure 2.1 represents the equivalent circuit of transformer to model an induction motor. In the equivalent circuit R_1 represents, the resistance of the stator winding and

X_1 the stator leakage reactance (flux that does not link with the air gap and rotor). Magnetising reactance required to cross the air gap is represented by X_m and core losses (hysteresis and eddy current) by R_c .

An ideal transformer of N_1 and N_2 turns respectively represents the air gap. For the rotor side, the induced electromagnetic field (emf) is affected by the slip (as the rotor gains speed, slip reduces and less electromagnetic field is induced). The rotor resistance and reactance are represented by R_2 and X_2 ; with X_2 being dependant on the frequency of the induced rotor electromagnetic fields. In the rotor circuit, the current I_2 is given by:

$$I_2 = \frac{sE_2}{\sqrt{(R_2)^2 + (sX_2)^2}} \quad (2.1)$$

By simplified equation (2.1), this can be written as;

$$I_2 = \frac{E_2}{\sqrt{\left(\frac{R_2}{s}\right)^2 + (X_2)^2}} \quad (2.2)$$

2.2.2 Formula to Calculate Inrush Current

Figure 2.2 presents the per phase equivalent circuit of an induction machine. From this circuit, one can derive the equations for calculating the inrush current and the starting torque in an induction machine (M.Thirugnanasambandamoorthy et.al, 2011):

$$I_{INRUSH} = \frac{V_1}{R_1 + j(X_1 + X_m) - (jX_m)^2 - (jX_m)^2 / [R_2 + j(X_2 + X_m)]} \quad (2.3)$$

$T_{STARTING} =$

$$\frac{1.35582 \times (21.1/n_s) V_1^2 jX_m R_2}{[R_2 (jX_1 + jX_m) + R_1 (jX_2 + jX_m)]^2 + [-R_1 R_2 + jX_1 jX_2 + jX_m (jX_1 + jX_2)]^2} \quad (2.4)$$

$$n_s = \frac{120 f}{p} \quad (2.5)$$

Where n_s is synchronous speed (rpm), f is nominal frequency and P is poles.

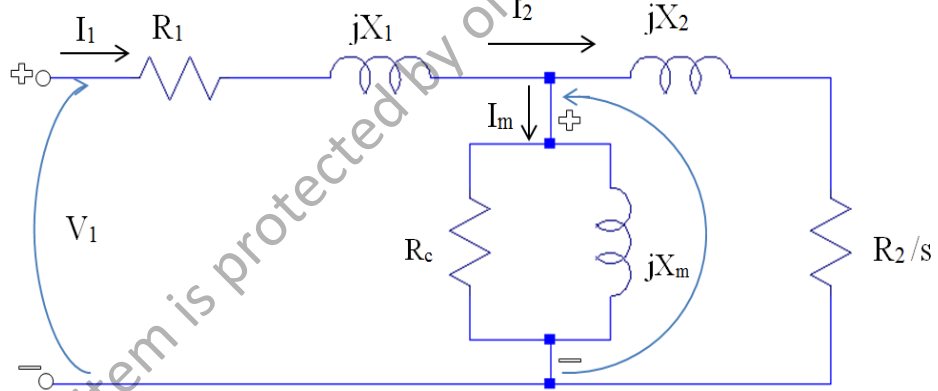

Figure 2.2: Induction machine per phase equivalent circuit (M.Thirugnanasambandamoorthy et.al, 2011)

Where I_{INRUSH} is per phase locked rotor current (A) and $T_{STARTING}$ is locked rotor torque (N.m). V_1 is per phase voltage (Volts), jX_M is per phase magnetizing reactance (Ohms), R_1 is per phase stator resistance (Ohms), jX_1 is per phase stator reactance (Ohms), R_2 is per phase rotor resistance (Ohms), jX_2 is per phase rotor reactance (Ohms) and R_{fe} is per phase core resistance (Ohms).

The stator and rotor resistances do not have a significant effect on the calculation of the inrush current. Varying these quantities by a factor of 2 would only change this current by less than 5% for a large induction motor. The inrush current is however

inversely proportional to the stator and rotor reactance. This means that the motor designer has the option to vary these parameters to obtain the desired design characteristics. These parameters are also defined in terms of reactance to resistance (X/R) ratio of a machine. A low inrush current motor has a much higher reactance than a standard motor. By choosing the appropriate slot widths, heights, number of stator to rotor slot and managing higher coil throw, the motor designer can control the reactance. The starting torque, just like the inrush current, is not strongly affected by the stator resistance. It is however inversely proportional to the square of the stator and rotor reactance, and proportional to the rotor resistance. Consequently, the designer has the option to reduce the bar area and/or decrease the electrical conductivity of the material in order to increase the starting torque, in addition to varying the slot widths and heights. One can notice that decreasing the inrush current comes at the disadvantage of a lower starting torque if only the reactance is changed.

2.3 High Current during Start up Induction Motor

Figure 2.3 presents the inrush current occur during start up three-phase induction motor (direct connected with three-phase supply). High inrush current occur for a few second during start-up induction motor and back to motor nominal current after a few seconds.

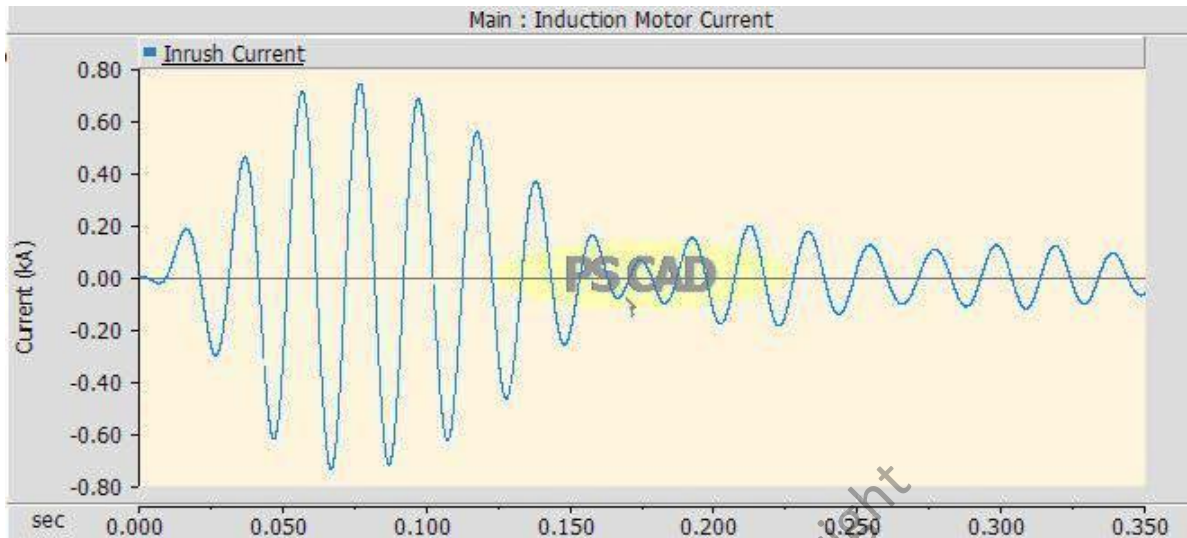

Figure 2.3: Inrush Current during starting induction motor

In a three phase induction motor, the magnitude of an induced electromagnetic field in the rotor circuit depends on the slip of the induction motor. This induced electromagnetic field effectively decides the magnitude of the rotor current.

Whenever a squirrel-cage induction motor is started, the electrical system experiences a current surge and the mechanical system experiences a torque surge. With line voltage applied to the motor, the current can be anywhere from six to eight times the rated current of the motor (Pillay et al. 2009). The magnitude of the torque (turning force) that the driven equipment will see could be in excess of 200% of the motor full-load torque. These current and torque surges can be reduced substantially by reducing the voltage supplied to the motor during starting.

At the moment of energization, the current drawn by a squirrel-cage induction motor is a function of its locked rotor impedance. Since starting current is determined by the impedance of the motor while starting, reduction of the stator voltage will reduce the starting current requirement. If the starting voltage is reduced to 50% of its nominal value, the starting current will also reduce by the same percentage in accordance with Ohm's Law;

$$I = \frac{E}{Z} \quad (2.5)$$

Where I is the starting current, E is the voltage applied to the motor and Z is the locked-rotor impedance of the motor. Since Z is essentially a fixed value at the instant of starting, any change in voltage will directly affect the starting current. Previous researchers in motor starting circuits in term of high inrush current are done. Hui Hwang et.al (2010) have investigated starting current of induction machine using conventional methods which are comparison among direct online starters (DOL), Star delta starter and autotransformers starting. They identified that during starting induction motors, the inrush current causes the voltage at the motor terminals to drop in magnitude. Their researches have used the PSCAD/EMTDC software to investigate high inrush current of induction motor.

2.4 Effect of High Starting Current

Due to such heavy inrush of current at start-up there is possibility of damage of the motor winding. Similarly such sudden inrush of current causes large line voltage drop and can cause overheating the motor itself. Thus other appliances connected to the same line may be subjected to voltage spikes which may affect their working. Furthermore, high inrush currents drawn by induction motor during starting can result in large dip in connected bus voltages. This dip in bus voltages can impact the performance of other motors operating on the bus. Voltage dips during starting of large motors can trip some of the motors operating on the same bus. Therefore, a procedure must be taken to limit the inrush currents during starting of the motor by employing

proper starting methods. For large motors life of the machine depends on the number of starting. High inrush currents can cause increase in the temperature of the machine, damages the insulation and can reduce the life of the machine.

To avoid such effects, it is necessary to limit the current drawn by the motor at start. The starter is a device which is basically used to limit high starting current by supplying reduced voltage to the motor at the time of starting. Such a reduced voltage is applied only for short period and once rotor gets accelerated, full normal rated voltage is applied. The starter not only limits starting current but also provides the protection to the induction motor against overloading and low voltage situations.

2.5 Motor Standards on motor Inrush Current

Previous researcher M.Thirugnanasambandamoorthy et.al (2011) has discussed about three key industry standards for motors that specify the requirements of torque and inrush current. The three key standards are National Electrical Manufacturers Association (NEMA, 2009-2010), American Petroleum Institute(API, 2011) and International Electro-technical Commission (IEC). A brief summary of induction motor performance standard is provided in Table 2.1. The torque and inrush of a motor are generally related to each other (M.Thirugnanasambandamoothy et al., 2011). Table 2.1 presents the motor performance standard among NEMA, API and IEC.