



**Design and Simulation of 33/11 kV Transformer Protection  
Using MATLAB Simulink**

by

**Afiq Faiez Bin Zulkeflee  
(2232223085)**

A dissertation submitted in partial fulfillment of the requirements for the  
degree of  
Master of Science (Program Mix-Mode/Coursework)

**Faculty of Electrical Engineering & Technology  
UNIVERSITI MALAYSIA PERLIS**

2024

## ACKNOWLEDGEMENT

I am overwhelmed in all humbleness and gratefulness to acknowledge my debt to my friend and circle who have helped and supported me during my postgraduate study and finish this research project.

I would like to express my special thanks of gratitude to all lecturers as well as my supervisor Dr Amizah Md Ariffen and Ir. Ts. Dr. Wooi Chin Leong as my co supervisor who gave me the golden opportunity to do this project on the topic Design and Simulation of 33/11 kV Transformer Protection Using MATLAB Simulink which also helped me in doing a lot of research and I came to know about so many new things. I am thankful to them. I am making this project not only for marks but also to increase my knowledge.

Also, I would like to thank my beloved wife and family for their support and encouragement. Without that support from beginning until the end, I couldn't have succeeded in completing this project.

Lastly, I would like to thank everyone who helped and motivated me to finish this project till the end.

## TABLE OF CONTENTS

	<b>PAGE</b>
<b>ACKNOWLEDGEMENT</b>	<b>ii</b>
<b>TABLE OF CONTENTS</b>	<b>iii</b>
<b>LIST OF TABLES</b>	<b>vi</b>
<b>LIST OF FIGURES</b>	<b>vii</b>
<b>LIST OF ABBREVIATIONS</b>	<b>ix</b>
<b>LIST OF SYMBOLS</b>	<b>x</b>
<b>ABSTRAK</b>	<b>xi</b>
<b>ABSTRACT</b>	<b>xii</b>
<b>CHAPTER 1 : INTRODUCTION</b>	<b>1</b>
1.1 Research Background	1
1.2 Problem Statement	2
1.3 Research Objectives	3
1.4 Scope and Limitation	3
<b>CHAPTER 2 : LITERATURE REVIEW</b>	<b>5</b>
2.1 Introduction	5
2.2 Transformer protection	5
2.3 Differential protection for internal fault	6
2.4 Differential Relay Protection for Prototype Transformer	7
2.5 Design of differential relay operation	9
2.6 Summary of Past Studies.	9
2.7 Summary of Literature Review	16

<b>CHAPTER 3 :</b>	<b>METHODOLOGY</b>	<b>21</b>
3.1	Introduction	21
3.2	Research Design	21
3.2.1	Parameters of Step-Down Transformer 33/11 kV	22
3.2.2	Calculation of Full-load current, CT ratio for HV and LV side and Pick-up Value of Differential Relay.	23
3.2.3	Modelling of Differential Relay Protection	25
3.2.4	Simulation for Power System Without Differential relay for Transformer Protection	26
3.2.5	Simulation Protection for Power System with Differential Relay Transformer Protection for Internal Fault and External Fault.	27
3.3	Overall Flowchart	28
3.4	Single-Line Diagram	30
3.5	Summary	31
<b>CHAPTER 4 :</b>	<b>RESULTS AND DISCUSSION</b>	<b>32</b>
4.1	Introduction	32
4.2	Simulation Overview.	32
4.3	Simulation Results for the Power System Under Fault and Without Relay (L-G)	33
4.4	Simulation Results for the Power System Under Fault and with Differential relay (L-G) at Internal Fault	35
4.5	Simulation Results for Current and Voltage Under Unsymmetrical Fault with Differential Relay at Internal Fault (L-G)	38
4.6	Simulation Results for Current and Voltage Under Unsymmetrical Fault with Differential relay at Internal Fault (L-L-G)	39
4.7	Simulation Results for Current and Voltage Under Unsymmetrical Fault with Differential Relay Outside Protective Zone (L-L-G)	40

4.8	Simulation Results for Current and Voltage Under Symmetrical Fault with Differential Relay at Internal Fault (L-L-L)	42
<b>CHAPTER 5 : CONCLUSION</b>		<b>44</b>
5.1	Conclusion	44
5.2	Future recommendation	45
<b>REFERENCES</b>		<b>46</b>
<b>APPENDIX A DISRIBUTION LINE 33KV WITHOUT DIFFERENTIAL RELAY</b>		<b>48</b>
<b>APPENDIX B DISTRIBUTION SYSTEM 33KV WITH DIFFERENTIAL RELAY</b>		<b>50</b>

©This item is protected by original copyright

## LIST OF TABLES

	<b>PAGE</b>
Table 2.1 : Summary of Literature Review	16
Table 3.1: Parameters of transformer	22

©This item is protected by original copyright

## LIST OF FIGURES

	<b>PAGE</b>
Figure 2.1: Implementation of differential relay to protect transformer	6
Figure 2.2: Operating quantity of line differential protection in	6
Figure 2.3: Operating quantity of line differential protection in case of and internal fault	7
Figure 2.4: Differentials relay current at the time for out of zone	8
Figure 2.5: Sub-system of Differential Relay	9
Figure 3.1: Modelling Differential relay in Simulink.	25
Figure 3.2: Fault Simulation without Differential Relay.	26
Figure 3.3: Distribution System Simulation with Differential Relay and Fault.	27
Figure 3.4: Overall Flowchart	30
Figure 3.5: Single-Line Diagram for Transformer Protection	31
Figure 4.1: Voltage reading during Fault Without Relay (L-G)	34
Figure 4.2: Current Reading during Fault Without Relay (L-G)	34
Figure 4.3: Simulation of Current during Fault Before Transformer (L-G) at Internal Fault	36
Figure 4.4: Simulation of Voltage during Fault before Transformer (L-G) at Internal Fault	37
Figure 4.5: Simulation of Current During Internal Fault (L-G) at LV side	39
Figure 4.6: Simulation of Voltage During Internal Fault (L-G) LV side	39

Figure 4.7: Simulation of LLG Fault Red Phase & Yellow Phase LV side	40
Figure 4.8: Simulation on Voltage during LLG Fault LV side	40
Figure 4.9: Simulation on Current During LLG Fault Outside Protective Zone at LV side	41
Figure 4.10: Simulation on Voltage During LLG Fault Outside Protective Zone at LV side	41
Figure 4.11: Differential Relay Output During External Fault	42
Figure 4.12: Simulation on Current During LLL Internal Fault at LV side	42
Figure 4.13: Simulation on Voltage During LLL Internal Fault at LV side	43
Figure 4.14: Differential Relay Output Signal	43

©This item is protected by original copyright

## LIST OF ABBREVIATIONS

ANN	Artificial Neural Network
AC	Alternate Current
ACB	Air Circuit Breaker
CT	Current Transformer
DFIG	Doubly-Fed Induction Generator
EPS	Electric Power System
EMTDC	Electromagnetic Transients including DC
GIS	Gas Insulated Substation
HV	High Voltage
HVDC	High-Voltage Direct Current
IDMT	Inverse Definite Minimum Time Relay
kV	Kilovolt
LV	Low Voltage
MCB	Miniature Circuit Breaker
UV	Under Voltage

©This item is protected by original copyright

## LIST OF SYMBOLS

$X_c$	Capacitor Reactance
$X_s$	Distance Source Reactance
$I_{diff}$	Differential Current
$I_{res}$	Resistive Current
$I_A$	Current Phasor
$I_p$	Primary Current
$I_s$	Secondary Current
$I_{operate}$	Operating Current
$V_1$	Primary Voltage
$V_2$	Secondary Voltage
$L_p$	Primary Induction
$L_s$	Secondary Induction
$P$	Power

©This item is protected by original copyright

## **Reka Bentuk dan Simulasi Perlindungan Pengubah 33/11 kV Menggunakan Matlab Simulink**

### **ABSTRAK**

Perlindungan pengubah mendekati keutamaan perlindungan pembezaan, dengan cara meningkatkan perbandingan terhadap tiada kerosakan dan senario kerosakan dalaman. Apabila kegagalan berlaku, adalah penting untuk mengeluarkan pengubah dari zon operasi secepat mungkin untuk mengelakkan kerosakan pada gegelung. Perlindungan pembezaan mengenal pasti kerosakan dalam zon perlindungan dan memutuskannya dengan sewajarnya. Geganti sedemikian biasanya digunakan dalam melindungi peralatan elektrik kerana sensitiviti dan kebolehpercayaannya yang tinggi. Perlindungan pembezaan memerlukan kuasa input pengubah untuk dipadankan dengan kuasa outputnya. Di bawah tetapan biasa, tiada arus yang mengalir melalui gegelung geganti apabila arus sekunder sesuai. Apabila masalah berlaku, arus yang melalui tidak akan seimbang. Untuk mengaktifkan pemutus litar dan mengasingkan pengubah yang rosak, isyarat perjalanan akan dihantar oleh geganti. Oleh itu, kajian ini tertumpu kepada reka bentuk perlindungan geganti pembezaan bagi perlindungan pengubah 33/11 kV. Kemudian kesan geganti yang ditetapkan akan dianalisis sama ada ia berjaya dikesan setiap kali kerosakan berlaku dalam zon perlindungan pengubah. Keseluruhan sistem kuasa dimodelkan dan disimulasikan, termasuk pengubah dan pemutus litar dengan kerosakan luaran di pelbagai lokasi ditetapkan secara rawak pada sistem berdasarkan kajian terdahulu.

# **Design and Simulation of 33/11 kV Transformer Protection Using Matlab Simulink**

## **ABSTRACT**

Transformer protection approaches priorities differential protection, with attempts to enhance based on comparing no fault and internal fault scenarios. When a failure occurs, it's important to remove the transformer from the operational zone as soon as possible to avoid damage to the coils. Differential protection identifies faults in the protection zone and disconnects it appropriately. Such relays are commonly employed in protecting electrical equipment because of their high sensitivity and reliability. The differential protection requires the transformer's input power match its output power. Under regular settings, there is no current flowing through the relay coil when the secondary current is suitable. When a problem evolves, the currents will not be balanced. To activate the circuit breakers and isolate the faulted transformer, trip signal will be sent by the relay. Therefore, this study is focused on the design of the differential relay protection for transformer protection 33/11 kV. Then the effect of designated relay analyzed whether it's successfully detected whenever the fault occurs within transformers protected zone. The whole power system was modelled and simulated, including the transformer and circuit breaker with an external fault at various locations are randomly set on the system based on previous studies.

©This item is protected by Copyright

# CHAPTER 1 : INTRODUCTION

## 1.1 Research Background

In the modern world, a reliable electric power system is supposed to ensure that all connected loads have continuous access to electricity. Power is typically transmitted by high-voltage transmission lines, which are exposed to the elements and subject to collapse from storms, falling items, insulator damage, etc. These may lead to both mechanical harm and an electrical malfunction. It has been extensively used from the generating side to the end load of the power system. To attain high selectivity, cost-effectiveness, and dependability, this was necessary. Surge protectors, circuit breakers, undervoltage relays, overcurrent relays, and many more devices are examples of overcurrent protection devices.

Protective relays and relaying systems detect abnormal conditions like faults in electrical circuits and automatically operate the switchgear to isolate faulty equipment from the system as quick as possible. This limits the damage at the fault location and prevents the effects of the fault spreading into the system.

Therefore, this study discusses about the design a differential relay on Transformer protection 33/11 kV. But the study was limit to high voltage (HV) since it covers for the incoming supply. This study was a good element to the society and the consumers side since it will discuss for the whole power system supply 33kV and power system protection serves as the first line of defence, rapidly detecting abnormal conditions and initiating appropriate actions to isolate faulty sections and restore normal operation. Without effective protection measures, the reliability, efficiency, and safety of power systems would be severely compromised.

Previously research already studied about the transformer protection. However, its limit for one objective only and without calculation of pickup value of relay. Thus, in this study, the power system 33kV was analysed during fault including line to line fault, line to ground fault and more including some of calculation for CT ration, full-load transformer and pickup value of relay. However, this failure can be affected by the human being or by the nature. Thus, this fault can be avoided if the system in a good protection and the components able to respond for any fault occurs in the system.

In addition, this study will be a lot of benefits to the society especially to the consumers side since power system protection is to detach the faulty section from the system to make the rest of the portion work without any disturbance. In addition to this, it is used for the protection of power systems and prevent the flow of fault current. It can help in preventing the continuation of flow by quickly from HV to LV disconnecting the short circuit. On the other hand, transformer protection is the important characteristic of power system protection helps to isolate the faculty part of the electrical system.

## **1.2 Problem Statement**

The power system is unpredictable. It can cause the system to fail and get worse by the fault. The condition distribution line can be affected by various situations such as maintenance, disaster, or others factor (Rafi et al. 2023a). Hence, the system should implement protection for power system. Besides, there are a lot of types of protection that can be applied depending on the situation and suitable for the system. In this study, the differential relays were chosen and it's can detect even minor imbalances between incoming and outgoing currents, enabling them to identify faults quickly and accurately.

Therefore, it was the first defence for power system during fault. Also, the setting for pickup value didn't mention by others researcher (Salih, Ibrahim, and Hamoodi 2021). Hence this study will show how to get the pickup value for CT setting.

### **1.3 Research Objectives**

The aim of this study is to design and simulation of transformer protection 33/11 kV using MATLAB Simulink. The objectives of this study are:

- a) To model and simulate the transformer with differential relay for normal and fault conditions.
- b) To analyze the effect of the internal and external fault condition on the voltage and current signals and the operation of differential protection.

### **1.4 Scope and Limitation**

The primary focus of this study is to design a transformer protection 33/11 kV with differential relay during fault and after fault. The design process will encompass the selection of relay, transmission voltage, Switchgear, transformer, and circuit breaker. The electrical components as mentioned will response to the fault and isolate the system for the protection. Factors such as stability of the voltage and faults occurs were consider during designing the simulation. The study will involve the development of a comprehensive simulation model using MATLAB Simulink to assess the performance of the design distribution line system. Key performance parameters, including input voltage, rated voltage for equipment, and output voltage, were simulated under various operating conditions and faults. This simulation will provide valuable insights into how the system

behaves and performs, helping to identify relay responds to the source voltage and fault. The primary objective of this study is to analysed the voltage and current during fault by using differential relay. To achieve this, the system will undergo simulation based on real-world conditions. Various scenarios were tested, and measurements of power and voltage output were taken. The results of these tests were critical in determining whether the system is suitable for its intended purpose, particularly in providing protection to the system. Based on the simulation results and evaluation of the system's performance, recommendations were made regarding to the relay in power system. These recommendations will aim to enhance the system's efficiency, reliability, and its ability to meet the specified energy requirements. It is important to acknowledge the limitations of this study. The scope is focused on the design, simulation, and evaluation of differential relay operating due to fault on distribution system for a specific load requirement (voltage 33 kV). Other aspects of the relay and rated equipment voltage may not be fully addressed within this study.

## CHAPTER 2 : LITERATURE REVIEW

### 2.1 Introduction

One of the most crucial components of an electrical power system is the protective system for power distribution lines. A distribution system is one that runs between distribution and generating hubs. The electrical sector uses two primary power transmission systems. Distribution line protection is achieved via differential relays, which are easy to install. The high-speed functioning of differential relays is one of its advantages. Line differential protection is, removing faults only on the guarded line. To determine the operational amount  $\Delta I$ , line differential protection measures the current phasors  $I_A$  and  $I_B$  flowing into the protected line from bus A and B, respectively. Internal faults can be detected by increasing the operating amount, causing the line to trip

### 2.2 Transformer protection

A differential relay can be installed on each transformer unit to provide protection. This relay's protection approach compares current inputs from both high and low voltage sides of the transformer. Under normal conditions or external faults, the current entering the protected unit is about equal to the current exiting it, considering the transformer's turn ratio. Ideally, no current flows through the relay unless there is a failure in the protected unit. Microprocessor-based relays offer additional protective features including thermal overload (monitoring winding temperatures) and over/under frequency relays. Thermal overload relays prevent winding insulation degradation by working in tandem with transformer energy losses, which rise with frequency. Figure 2.1 depicts the attachment of a differential relay for transformer protection. (Leelaruji and Vanfretti 2011)

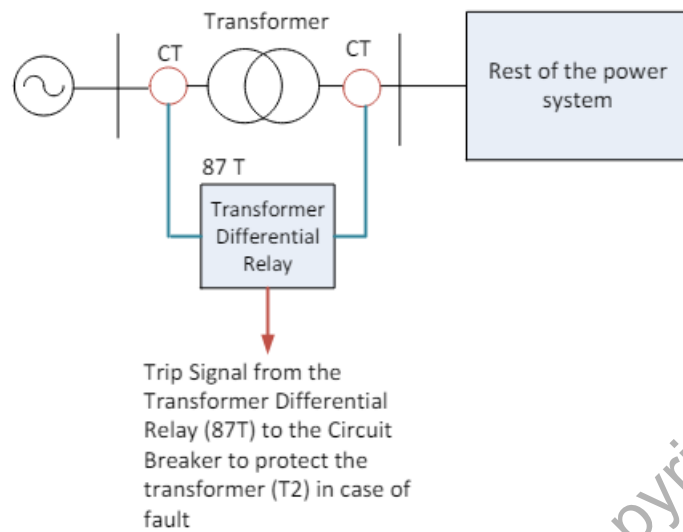

Figure 2.1: Implementation of differential relay to protect transformer

### 2.3 Differential protection for internal fault

Figure 2.2 depicts the situation in the event of an external malfunction. For an external failure, the operational amount  $\Delta I$  is minimal since the current  $I_A$  from bus A enters the protected line and exits at bus B as  $(-I_B)$  is not equal.

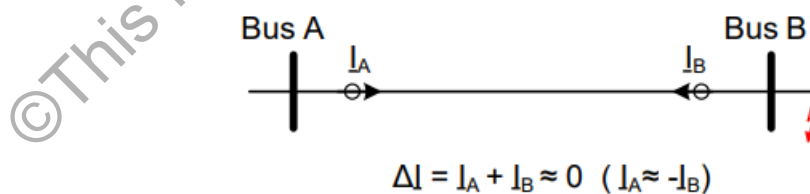

Figure 2.2: Operating quantity of line differential protection in case of an external fault

Figure 2.3 show the computation of operational quantities according to current phasors. Other methods use sampled measured current levels or polarity to derive

operational quantities. However, all of these techniques need synchronisation of current measurements on both ends of the connection. Analogue technology transmits the secondary output of the current transformer to the remote end using wires parallel to the protected line. This concept limits the maximum length of a line for differential protection. Line differential protection utilises differential current  $I_{diff}$ , which is equal to the total of all currents flowing into the protected zone as calculated by formula: (Blumschein, Kerger, and Matussek n.d.)

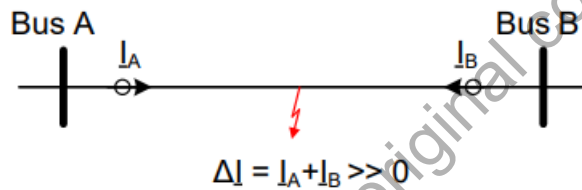

Figure 2.3: Operating quantity of line differential protection in case of and internal fault

$$I_{diff} = |\sum_{k=1}^n i_k| \quad 2.1$$

$$I_{res} = \sum_{k=1}^n |i_k| \quad 2.2$$

#### 2.4 Differential Relay Protection for Prototype Transformer

Differential protection is the main focus of transformer protection techniques, and efforts to enhance transformer protection were predicated on a comparison between internal fault and no fault. Transformer must be removed from the operational zone as soon as possible after the problem occurs in order to minimise or avoid potential damage to the coils. The expense of fixing transformer damage is quite significant. A power transformer's unforeseen outage may also be expensive and economically pointless. Thus, the protective system for power transformers is subjected to significant demands. The

differential protection guards against the fault that occurred in the protection zone and provides the appropriate action to disconnect the zone.

In essence, differential protection relies on the transformer's input power matching its output power. This is achieved by the use of differential relays. Standard circumstances state that there is no current flowing through the relay's coil when the secondary currents are flowing appropriately. Every time a fault occurs, there will never be a state of equilibrium in the currents, and the relay connections must be closed in order to provide a trip order signal that triggers the circuit breakers and isolates the malfunctioning device. A single phase of a three-phase differential protection system (DPS) is shown in Figure 2.5. A few of CTs surrounded the protective gear. As compared to the other system equipment, differential relay protection will not provide backup protection due to the inherent tendency of CTs; as a result, this type of protection diagram is frequently used as a unit protection schedule. (Salih et al. 2021)

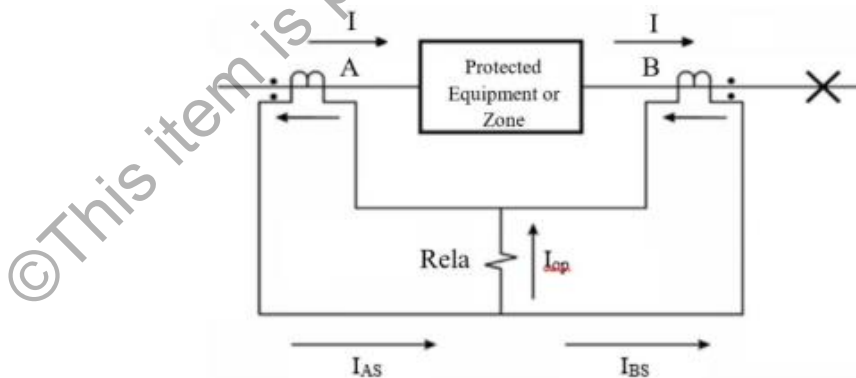

Figure 2.4: Differentials relay current at the time for out of zone

## 2.5 Design of differential relay operation

In Figure 2.6, The subsystem uses logical operations to offer the necessary production for a differential relay. The three-phase currents that were multiplexed have been demultiplexed inside the sub-system. The current values' RMS value is utilised for comparison. Input 2 from the transformer's high voltage side doubles the current three times. In typical working conditions, the resulting of the deduction should be 'LOW'. Under defective situations, the two sides of a transformer might produce different current magnitudes. (Rafi et al. 2023a)

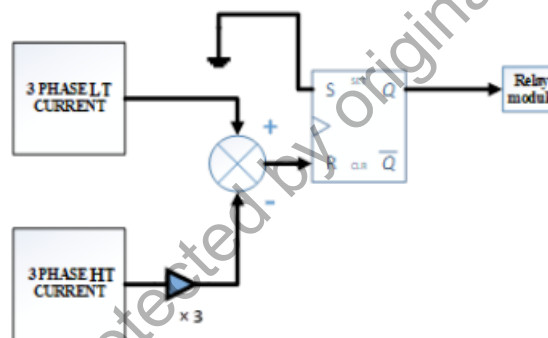

Figure 2.5: Sub-system of Differential Relay

## 2.6 Summary of Past Studies.

Firstly, Behrooz Taheri did research on a new method for the end-to-end differential relays. The electric power transmission sector has traditionally prioritised power system stability. Protection mechanisms play a crucial role in maintaining stability. One major issue with these systems is that they identify defects only when there is a failure. If the protective mechanism does not function properly, the power system may become unstable. Periodic testing of protection systems is necessary to prevent incidents like this. This research presents a new approach for testing the longitudinal differential

protective relay from end to end. This technology was applied on Vebko Amirkabir Company's AMT-105 relay testing equipment. The method was evaluated in both laboratory and real-world scenarios, using real-life relays. The test findings are expressed in several fault kinds. The findings indicate that the algorithm performs consistently across faults with minimal variation (Behrooz Taheri 2019).

Pakhmutova A.A, Blagorazumov D.O did research on development of functional requirement for busbar differential relay and breaker failure protection. This study is about the functional criteria for busbar protection devices were developed to comply with regulatory and legal requirements and operational standards. The assignment entailed assessing the safety standards for PAC devices with bus section, bus bar, bus coupler breaker, and bypass switch relay protection functionalities. In addition, device manuals for comparable PAC devices produced by "EKRA" LTD and "Relematica" LTD were examined (Pakhmutova et al. 2023).

A.dos santos, J.F. Martins studied the line differential protection system based on low power stand-alone current sensor. They present a unique method for high-voltage power line protection based on differential protection ethics and currents monitored by Rogowski Coil current sensors. This system is intended for use on four in-service 220 kV power cables that connect a gas-insulated substation (GIS) to overhead lines. Extensive testing was performed on the protection approach in a high-power test and in a field application that demonstrated rigorous electrical system usage circumstances. All testing confirmed the solution's strong reliability and security (Dos Santos et al. 2010).

System for automatic calculation of relay protection set point had done by the A.A. Voloshin, E.A. Voloshin, A.I. Kovalenko. The Russian and international scientists have examined the challenges of implementing relay protection in distribution networks and potential solutions. The authors of articles discuss the implementation of step-based protections with relative selectivity for active distribution networks. They conclude that traditional overcurrent and distance protection designs do not fully support these protections. Using a "weak" source of generation can reduce overcurrent protection sensitivity by up to 1.7 times. The author suggests differential and adaptive backup protection. The publication includes materials that demonstrate various options for executing adaptive safeguards with relative selectivity. The paper proposes two sorts of solutions: the first employs interlocks between nearby safeguards to ensure flexibility, while the second relies on automated changes in protection device parameters during network operation (Voloshin et al. 2020).

Li Bin and Du DingXiang investigated on improved differential-current protection for ac transmission line connecting renewable energy power plant and MMC-HVDC system. They found through simulation; the issue of differential-current protection's sensitivity decrease is confirmed. It is suggested to use an improved criterion for differential current protection. Protection criteria considers the angular data for the current that causes the fault on either side, changing the stopping factor from the same to a value that changes as the angle considered. Comparing to ratio braking differential-current protection, the improved criterion-based differential-current protection increases protection sensitivity without compromising reliability. It also picks the B value depending on the highest included direction, which improves safety sensitivity and dependability.

Lastly, the simulation results confirm that the differential-current protection, which is based on the revised criteria, is effective (Bin et al. 2021).

On another research paper, Sanjay Dambhare and S.A Soman investigated on Adaptive current differential protection scheme for transmission line protection. In this research, they present a strategy for adaptive control of the regulating area in a current differential plane. First, utilizing the idea of dynamic phasor, an error analysis of the typical phasor technique for current differential protection is provided. Following that, they expanded the approach for series compensated transmission line protection. Finally, they use phasor lets to assess the speed versus accuracy trade-off. The statements are supported by simulations of the Electromagnetic Transient Program. The findings illustrate the applicability of the suggested method (Dambhare, Soman, and Chandorkar 2009).

Rakayet Rafi and A.B.M. Noushad Bhuiyan investigated on analysing the efficacy of differential relay systems for transformers protection under differential internal faults. In this paper, the realize Transformer protection is vital since they are an integral part of the electric power system. Extremely rapid and focused protective actions are needed to mitigate the danger of transformer damage during faults. Using the MATLAB/Simulink platform, the act of a differential relay was effectively running in this work. An Artificial Neural Network (ANN) was trained using the data from the suggested model to forecast relay tripping. Investigating how to shield the power transformer from internal defects and stop intrusion with the power system was the major goal. Several tenable fault situations were assessed. The performance of the relays under various failure scenarios and system features was carefully investigated. Additionally,