



**Beam- Reconfigurable of a Planar Parasitic Pixel
Antenna for X-Band Radar Application**

by

**DEVAKUMARAN A/L SUBRAMANIAM
(1630812103)**

A thesis submitted in fulfillment of the requirements for the degree of
Master of Science in Communication Engineering

School of Computer and Communication Engineering

UNIVERSITI MALAYSIA PERLIS

2018

ACKNOWLEDGMENT

First and foremost, I thank God for the blessings to complete my master journey. This master journey could be completed without positive supports that I received from many people.

It gives me a great pleasure to express my sense gratitude to my master supervisor, Assoc. Prof Dr. Muzammil Jusoh for his valuable guidance, freedom, motivation and constant encouragement in completing this research with successfully. Special thanks to my co-supervisor, Dr. Thennarasan Sabapathy for his support and guide until the end of the research.

I also would like to extend my sincere thanks to Prof. Mohd Tarmizi Ali for supporting my measurement work at Universiti Teknologi MARA (UiTM) Shah Alam.

A million thanks to the Research and Innovation (University Malaysia Perlis) for the financial support of my MSC.

Besides, I also would like to convey my gratitude to all my colleagues especially Dr Nasrun Osman, Mohd Ilman Jais, LMurukesan Loganathan and Iszaidy Ismail for sharing the knowledge and opinion to assist my master research.

A million thanks to my parents, Subramanian and Anbu Selvi for the support and motivation for completing my master work. To my future wife, Shantini Prakash who has always been constantly encourages and supports me during my master journey.

TABLE OF CONTENTS

	PAGE
DECLARATION OF DISSERTATION	i
ACKNOWLEDGMENT	ii
TABLE OF CONTENTS	iii
LIST OF TABLES	v
LIST OF FIGURES	vi
LIST OF ABBREVIATIONS	x
LIST OF SYMBOLS	xi
ABSTRAK	xii
ABSTRACT	xiii
CHAPTER 1 : INTRODUCTION	1
1.1 Research Background	1
1.2 Problem Statement	4
1.3 Research Objective	5
1.4 Research Scope	6
1.5 Contributions	7
1.6 Thesis Outline	8
CHAPTER 2 : LITERATURE REVIEW	9
2.1 Introduction	9
2.2 Classification of Reconfigurable Antenna	9
2.3 Reconfigurable Antenna Switch Technology	10
2.3.1 Switching Reconfiguration	11
2.3.2 Material Reconfiguration	12
2.3.3 Movable Reconfiguration	13
2.4 Reconfigurable Radiation Pattern Antenna	14
2.4.1 Previous Research on Reconfigurable Radiation Pattern Antenna	16
2.9 Motivation for Present Research	22
CHAPTER 3: METHODOLOGY	23
3.1 Introduction	23
3.2 Research Work Flow	24
3.3 Driven Antenna Structure	25

3.4	Driven Parasitic Antenna	26
3.5	Pixel Array	29
3.6	Combination of Driven Parasitic and Pixel Structure	33
3.7	Electromagnetic Simulation	34
3.8	Fabrication Process of the Antenna	35
3.9	Measurement Setup	39
3.10	Summary	41
CHAPTER 4: RESULT & DISCUSSION		42
4.1	Introduction	42
4.2	Driven Antenna	42
	4.2.1 Parameter Optimization of feed location	44
4.3	Driven Parasitic Antenna	46
	4.3.1 Optimizing the Positions of Shorting Pins in Parasitic Elements	52
4.4	Driven Pixel Layer Antenna	56
	4.4.1 Optimizing the Distance between the Driven Layer and the Pixel Layer	62
4.5	Driven Parasitic with Pixel Layer	66
4.6	Summary	71
CHAPTER 5: CONCLUSION		73
5.1	Conclusion of Project	73
5.2	Future Work	74
REFERENCE		75
APPENDIX A: PUBLICATIONS		82
A.	Conference	82
APPENDIX B: EXHIBITION		83
A.	Local	83

LIST OF TABLES

NO.		PAGE
Table 4.1	The result of feeding location from simulation	45
Table 4.2	Simulated RF PIN Diode switches configuration againts angle direction	47
Table 4.3	Simulated PIN Diode switches configuration	48
Table 4.4	Measured switches configuration	49
Table 4.5	Comparison of simulated and measured results based on switches configuration	52
Table 4.6	Comparison simulated results for different shorting pins position	53
Table 4.7	Simulated switches configuration of the driven pixel antenna	57
Table 4.8	Comparison simulated and measured of the driven pixel antenna	59
Table 4.9	Proposed antenna performance on various driven-pixel gap	63
Table 4.10	Simulated switches configuration of the driven parasitic pixel antenna	67
Table 4.11	Measured switches configuration of the driven parasitic pixel antenna	68
Table 4.12	Comparison of previous research design and result	72
Table 4.13	Comparison of propose research simulate design and result	72

LIST OF FIGURES

NO		Page
Figure 2.1	Reconfigurable Antenna Properties	10
Figure 2.2	Reconfiguration Techniques	11
Figure 2.3	Types of Reconfigurable Radiation Pattern (D. Rodrigo,2014)	14
Figure 2.4	Structure of Microstrip Leaky-Wave (R. O. Oued rafo, E. J. Rothwell, & B. J. Greetis, 2013)	16
Figure 2.5	Structure of Yagi-Uda Patch Array Antenna (T. Sabapathy & R. B. Ahmad, 2015)	17
Figure 2.6	Structure of FPPA (M. Jusoh & T. Sabapathy, 2014)	18
Figure 2.7	Measured and simulated radiation patterns of FPPA (M. Jusoh & T. Sabapathy, 2014)	18
Figure 2.8	Multifunctional reconfigurable antenna (MRA) (a) Structure of (MRA), (b) Radiation patterns (X. Yuan, Z. Li & D. Rodrigo, 2012)	19
Figure 2.9	Structure of parasitic pixel antenna (D.Rodrigo & B.A. Cetiner, 2014)	20
Figure 2.10	Planar patch driven element with rectangular grids (a) Radiaton Pattern and (b) Structure of antenna (P. Lotfi, S. Soltani, & R. D. Murch, 2016)	21
Figure 3.1	Driven antenna structure, (a) Top View & (b) Rear View	25
Figure 3.2	Driven Parasitic Antenna, (a) Top View, (b) Capacitor Connection, (c) PIN Diode & (d) Rear View	28

Figure 3.3	Pixel Structure (a) Front View, (b) DC grounding and RF Choke Inductor connection, (c) Overall DC Biasing connection and (d) DC Biasing	32
Figure 3.4	DC biasing circuit of the PIN Diode Switch	32
Figure 3.5	Combination structure of the driven and pixel layer	33
Figure 3.6	Combination structure of the driven parasitic pixel layer	34
Figure 3.7	Printing process of the design	35
Figure 3.8	Laminating process of the antenna	36
Figure 3.9	Chemical etching process	37
Figure 3.10	Structure of the antenna	38
Figure 3.11	Measurement Process for Reflection Coefficient	39
Figure 3.12	Radiation pattern measurement	40
Figure 4.1	Fabricated structure of the driven antenna	43
Figure 4.2	Measured and simulated reflection coefficients of the driven structure	44
Figure 4.3	Reflection coefficient of different position of SMA port	45
Figure 4.4	Measurement process of the driven parasitic antenna	46
Figure 4.5	Simulated reflection coefficient of the driven parasitic antenna for the respective beam configuration	47
Figure 4.6	Simulated radiation pattern of the driven parasitic antenna	48

Figure 4.7	Simulated and measured radiation pattern of driven parasitic antenna:(a) P1, (b) P2 and (c) P3	51
Figure 4.8	Measured reflection coefficient driven parasitic antenna	51
Figure 4.9	Structure of the driven parasitic antenna	53
Figure 4.10	Simulated radiation patterns for different positions of shorting pins: (a) 0 degree, (b) 40 degree	54
Figure 4.11	Structure and measurement process of the driven pixel antenna	56
Figure 4.12	Switch configuration of the pixel layer: (a) P1, (b) P2 and (c) P3	57
Figure 4.13	Simulated and measured reflection coefficient of the driven pixel antenna :(a) P1, (b) P2 and (c) P3	59
Figure 4.14	Simulated and measured radiation pattern: (a) P1, (b) P2 and (c) P3	61
Figure 4.15	The gap between the driven and pixel layer	62
Figure 4.16	Reflection coefficient parameters for air gap: (a) P1 and (b) P2	64
Figure 4.17	Beam steering parameter for different air gap: (a) P1and (b) P2	65
Figure 4.18	Structure of the driven parasitic pixel antenna: (a) Complete proposed structure, (b) Driven parasitic layer and (c) Pixel layer	66
Figure 4.19	The radiation pattern for driven parasitic pixel antenna	67
Figure 4.20	Radiation pattern of the driven parasitic pixel antenna at 9.5 GHz: (a) Simulated and (b) Measured	69

@This item is protected by original copyright

LIST OF ABBREVIATIONS

dB	Decibel
CST	Computer Simulation Technology
DC	Direct Current
EM	Electro-Magnetic
GHz	Giga Hertz
mm	Millimeter
RF	Radio Frequency
VSWR	Voltage Standing Wave Ratio
WLAN	Wireless Local Area Network

@This item is protected by original copyright

LIST OF SYMBOLS

θ	Theta
Γ	Reflection Coefficient
Ω	Ohm
η	Efficiency
ε	Permittivity
L	Inductor
pF	Capacitor

@This item is protected by original copyright

KEBOLEHUPAYAAN KAWALAN RADIASI UNTUK ANTENA UNTUK APLIKASI RADAR X-BAND

ABSTRAK

Kerja-kerja penyelidikan dalam tesis ini memberi tumpuan kepada pembentukan semula antenna “reconfigurable antenna” bagi aplikasi radar X-Band. Konsep ini memberikan lebih fleksibiliti kerana kemampuan mereka untuk mengubah suai sifat radiasi dan menyediakan pelbagai fungsi. Kajian ini melibatkan antenna pixel, di mana grid patch akan disambungkan dengan suis RF. Pengaktifan dan penyahaktifan suis ini dinamik boleh membentuk semula sifat-sifat antenna. Keupayaan ini menyediakan antenna pixel dengan tahap reconfigurability yang bagus, lebih tinggi daripada antenna lain. Walau bagaimanapun, pelaksanaan pixel antenna masih sangat terhad disebabkan oleh bilangan besar suis diperlukan. Prestasi antenna boleh terjejas daripada rangkaian suis RF yang kompleks. Oleh itu, kajian ini memberi tumpuan kepada pengurangan suis dalam antenna pixel untuk meningkatkan kecekapan antenna, dan mengurangkan kos antenna. Pertama, konsep parasitik diperkenalkan dengan gandingan “driven” dan “parasitic”. “Circular Patch” dipilih sebagai “driven” disebabkan ciri-ciri profil yang rendah, corak sinaran satu arah dan digunakan secara meluas. Lapisan “parasitic” diletak pada sebelah kanan dan kiri antenna dalam satu lapisan tunggal. Gandingan bersama “driven” dan “parasitic” dapat mencapai tiga sudut yang berbeza dalam satu lapisan iaitu -40° , 0° dan $+40^\circ$. “Driven parasitic antenna” ini berdasarkan daripada Yagi-Uda prinsip. Keduanya, kerja membentuk antenna pixel diteruskan. Lapisan pixel terletak di atas lapisan “driven” dengan “air gap” 7mm. Gandingan kukuh antara antenna “driven dan permukaan pixel mendorong arus yang ketara ke atas lapisan pixel, oleh itu memberi kesan kepada radiasi antenna. “Beam Steering” dicapai dengan memilih konfigurasi suis RF yang betul. Akhir sekali, gabungan “driven parasitic” antenna dengan lapisan pixel telah diperkenalkan. Kelebihan pendekatan ini, di mana “driven parasitic” dan gabungan lapisan pixel boleh mengemudi “beam steering” secara individu. Diod HPND-4005 telah digunakan untuk mengawal antara pixel dalam proses simulasi dan suis “copper” untuk proses pengukuran. Diod telah dimodelkan kepada dua keadaan iaitu ON dan OFF dalam simulasi. Prestasi antenna dianalisis dalam hasil simulasi dan diukur menunjukkan ia dapat dikawal sehingga -40° , 0° dan 40° dengan “gain” 7 hingga 10 dBi bagi setiap kawalan radiasi.

BEAM-RECONFIGURABLE OF A PLANAR PARASITIC PIXEL ANTENNA FOR X-BAND RADAR APPLICATION

ABSTRACT

The research work in this thesis focuses on the reconfigurable beam-steering antenna for the X-Band radar application. This concept gives more flexibility due to their ability to modify the radiation properties and providing multiple functionalities. The research involve the pixel array antenna, where a particular types of reconfigurable antenna with the grid of metallic patches that are interconnected by a RF- switch. The activation and deactivation of these switches can dynamically reshape the antenna properties. This capability provides pixel antennas with an extreme level of reconfigurability, much higher than in other architectures. However, pixel antenna implementation is still very limited due to the large number of required switches. Even the loss of the switches can easily effect the antenna efficiency due to the complex biasing networks. Therefore, this research focuses on reduction of switches in pixel antenna in order to improve the antenna efficiency, cost and reconfiguration speed. First, the concept of driven parasitic is addressed. A circular patch has been selected as driven antenna because of its low profile characteristics, unidirectional radiation pattern and widespread use. The parasitic layer is located on the right and left of the driven antenna in single layer. The mutual coupling between the driven and parasitic is able to steer beam to three different angles of -40° , 0° and $+40^\circ$ in single layer. This driven parasitic patch antenna based on Yagi-Uda principle. Secondly, this work continues on designing driven pixel antenna. The pixel layer is located on top of the driven layer with the air gap of 7mm. The strong coupling between the driven antenna and the pixel surface induces significant currents over the pixel layer, therefore affecting the antenna radiation pattern. The beam steering have been achieved by selecting the properly switch configuration. Finally, the combination of driven parasitic antenna with pixel layer has been introduced. The advantages of this approach, where the driven parasitic and combination of the pixel layer can steer the pattern individually. The HPND-4005 PIN diode has used as interconnecting between the pixels in the simulation process and copper switch for measurement process. The diodes have been modelled into two conditions as ON state and OFF state in simulation. The performance of reconfigurable antenna is analyzed in simulated and measured results. The proposed antennas can steer up to -40° , 0° and 40° with approximate gain of 7 to 10 dBi at all desired directions.

CHAPTER 1 : INTRODUCTION

1.1 Research Background

An antenna is an element that transmitting or receiving signal that generate from the electromagnetic waves. In the vast of wireless communication system, there are looking forward to develop antennas with multi functionality that can adapt with changing scenario and operating requirements. In this term, reconfigurable antennas fulfil the requirement. A reconfigurable antenna is an antenna that produces an internal mechanism to redistribute the RF-currents over its surface and thus alter the electromagnetic fields over the antenna impedance and/or radiation properties. Reconfigurable antennas can be classified into frequency, polarization and radiation pattern reconfigurable antennas.

Reconfigurable antenna has become an important and desired feature of modern, agile, radio-frequency (RF) systems for wireless and satellite communications, sensing, and imaging. Reconfigurable antenna is used wide by researcher due to the compactness and mobility. It can operate in multiple frequency and radiation pattern in a single device based on the requirement. The ultimate goal of reconfigurable antennas is to be able to independently adjust the frequency of operation, the antenna pattern and the polarization. In this context, reconfigurable antennas stand out as an excellent approach for future wireless. However, the development of the reconfigurable antenna lead to high complexity in order to design compact antenna while remaining the

performance level of the antenna. These are the reasons why some of the researcher moving towards minimize the complexity and maintain the performance level.

When designing a reconfigurable antenna, the researchers must consider which reconfigurable property to be modified such as frequency, radiation pattern or polarization. Moreover, they should identify which technique will give more advantages and minimizes negative effects on the antenna. Reconfigurable beam antennas can be classified into beam shaping and beam steering technique. The beam shape antennas are capable of steering the antenna radiation pattern at a specific direction with a certain number of gain levels. While the beam steer antennas have an ability to position a single beam pattern in one direction at a time. Significant reconfigurable antennas for beam steering application have been reported in (Ali, 2010; D. Rodrigo, 2014; Liu, 2010; M. Jusoh, 2014; T. Sabapathy, 2015). A number of research work concluded that the beam steer can be achieved with the monopole antenna design.

This research proposes parasitic and pixel concept to achieve a better reconfiguration results for reconfigurable antenna. This concept based on Yagi-Uda principle to enhanced the directional beam, increase the operating bandwidth and increase the gain. The first approach is selected circular patch as the driven antenna. The parasitic elements placed on the right and left side of the driven element. The driven element acts as a radiator and positioned in the middle of the antenna structure. It would be an ideal concept to establish a strong relation between the driven and parasitic element to modify the input impedance and radiation characteristics. The parasitic elements act as reflectors or director depending on the switching conditions. Both parasitic elements are connected to ground plane via shorting pins.

The second approach in this research is pixel array which consists of a small grid of microstrip patch composed in square matrix, where each pair of pixel patches is interconnected by an RF-switch. These pixel acts as radiating surface. By activating different switch configuration, the antenna surface modifies the frequency and radiation characteristics.

The first concepts of a reconfigurable pixel antenna were developed under name *switched fragmented aperture* in (J. Maloney, 2000) which perform the pixel concept to reconfigure dipole and monopole antenna. The second approach has been proposed in (D. Rodrigo, 2014 & P. Lotfi, 2016) where the pixel antennas divide the radiating surface in small sections, called pixels, and interconnect by the RF- switches.

This master thesis enhances the ability of parasitic and pixel array to perform beam steering angles in range of -40° to 40° . Besides that, each of the beam steering angles capable to achieve a high gain in range of 7 to 10 dBi. The antenna also features a low number switching element in the pixel layer compared to previous antennas (D. Rodrigo, 2011; P. Lotfi, 2016; X. Yuan, 2012). Only 20 numbers of switches are needed compared to the previous pixel antennas that have adopted more than 40 switches. The proposed antenna is simulated by using Computer Simulation Technology (CST) Studio Suite Software. The proposed antenna is chosen to be 9.5 GHz and the substrate used for the antenna is Taconic TLY-5 (Lossy) with dielectric constant, $\epsilon_r = 2.2$, the thickness is 1.57 mm and tangent loss of 0.0009.

1.2 Problem Statement

In previous reconfigurable antennas (M. Jusoh, 2014; P. Lotfi, 2016 & T. Sabapathy, 2015) have been design in single parameter reconfiguration techniques; however it has required high complexity of design switch biasing circuit and increases the switch losses and decreases the performance of the antenna. The antenna efficiency drops easily due to the effect of large number of switches with complex biasing circuit. The alternative methods used in the reconfigurable antenna is shorting pin, parasitic radiators and pixel array. Therefore, this research proposed a combination of driven, parasitic and pixel antenna which provide good beam-steering capabilities with higher gain and enhanced performance of the antenna. Pixel array is a flexible approach to implement beam steering capability using a parasitic pixel layer above the radiating element. The strong coupling between the driven antenna and the parasitic pixel surface induces significant currents over the pixel layer, therefore affecting the antenna radiation pattern. The main challenge is to minimize the complexity of pixel structure because it require larger amount of RF switches (D.Rodrigo, 2014 & P. Lotfi, 2016). Therefore the amount of RF switches has been minimize to 20 numbers for this research and at the same time, it is possible to tune the radiation pattern by properly selecting the switch configuration.

1.3 Research Objective

The objective of this master work is to develop beam- reconfigurable of a planar parasitic pixel antenna for X-Band Application as a conceptual structure into practical reconfigurable antenna architecture. The objectives are presented as follows:

- I. To design and evaluate a reconfigurable radiation pattern antenna using parasitic pixel approach while reduce the number of switches in order to maintain the efficiency level.
- II. To achieve a reconfigurable beam steering antenna with with approximate gain of 7 to 10 dBi and angle direction at -40° to 40° for the antenna.

1.4 Research Scope

Literature review about reconfigurable antenna had been done in order to understanding the design concept and for the parasitic pixel antenna. Besides that, the combination of driven parasitic and pixel had been studies before proceed with the design. In this research, three type of antenna had been proposed, consist of driven pixel antenna, driven parasitic antenna and combination of driven parasitic pixel antenna. All this antenna will be applied by the Yagi-Uda technique that already being proved for the parasitic and pixel antenna. All the design had been simulated by using CST Microwave Studio software. Once achieve the optimal result from the simulation then all the antennas are fabricated using Taconic substrate with dielectric constant of 2.2. All the prototypes is tested and measured using KEYSIGHT EN5234 PNA-L Network Analyzer and Atenlab (OTA-500) Chamber, for measuring the return loss and beam steering pattern. Then, the results were analyzed based on simulation and measurement of the antenna on the return loss, gain, beam steering pattern and etc.

1.5 Contributions

The main contributions of the research work presented in this thesis include:

- I. An improvement of reconfigurable antenna steering capability by combining reconfigurable driven parasitic antenna with pixel array. This approach have being proved that the combination of driven parasitic and pixel antenna can steer the pattern individually.

@This item is protected by original copyright

1.6 Thesis Outline

This research is divided into five chapters. In the first chapter include the introduction, problem statement, research objective, scope of the research, project contributions and thesis outline. The second chapter is the literature review of the project where contain the classification of reconfigurable antenna and properties of the switching technology. It provides the contributions and achievement of the previous projects in the reconfigurable radiation pattern antenna.

Chapter 3 include the methodology part which covered the overall research flow works. This methodology discusses the design specification of driven and parasitic antenna that include of the antenna material, feeding technique, switching technique and the capabilities of the antenna. Besides that, the concept of pixel antenna structure, switching ability, lumped components, biasing lines and the combination of driven and pixel antenna is presented. Finally, the antenna fabrication process and the measurement process is also covered in Chapter 3.

The performance level and the capability of the driven antenna, driven parasitic antenna, driven pixel antenna and combination of driven parasitic with pixel layer are presented in Chapter 4. The simulation optimization has been done by Computer Simulation Technology (CST) Studio Suite Software to achieve good impedance, gain, and radiation pattern for the proposed antenna. The proposed antenna has been fabricated and all the measurement work has been carried out. Finally, conclusion and future work has been draw.

CHAPTER 2 : LITERATURE REVIEW

2.1 Introduction

The development of wireless communications has changed the functionality and requirements in terms of compactness, mobility and integration of multiple applications into a single element. In this context, reconfigurable antenna becomes a key role for wireless application due to their ability to adjust their parameters such as frequency, radiation pattern, polarization and able to adapt based on the changing scenario.

2.2 Classification of Reconfigurable Antenna

The reconfigurable antenna provide the flexibility of operating frequency, radiation pattern, polarization and hybrid as depicts in Figure 2.1. The first properties is frequency reconfiguration that is able to modify the operating frequency by changing between various frequencies bands as wideband and narrowband (C. G. Christodoulou, 2012; J.T. Bernhard, 2007). The second properties is radiation pattern reconfiguration which capable to do beam steering and beam shaping. The most popular application in radiation pattern reconfiguration is beam steering, where it capable to steer the antenna for maximum gain in a desired direction.

The polarization reconfiguration is capable proficient to switch the antenna properties into linear or circular polarized. Linear polarization can be divided into horizontal, vertical and \pm Slant 45° polarizations, where circular polarization referred to

left-hand and right-hand polarization (RHCP) (M. F. Jamlos, 2012 & Y. Li, 2011). The hybrid properties are called as multimode reconfiguration. It is a combination of at least two properties mentioned or integration of all of them in a single antenna. It minimizes the antenna size; enhance system efficiency and decrease system cost and weight.

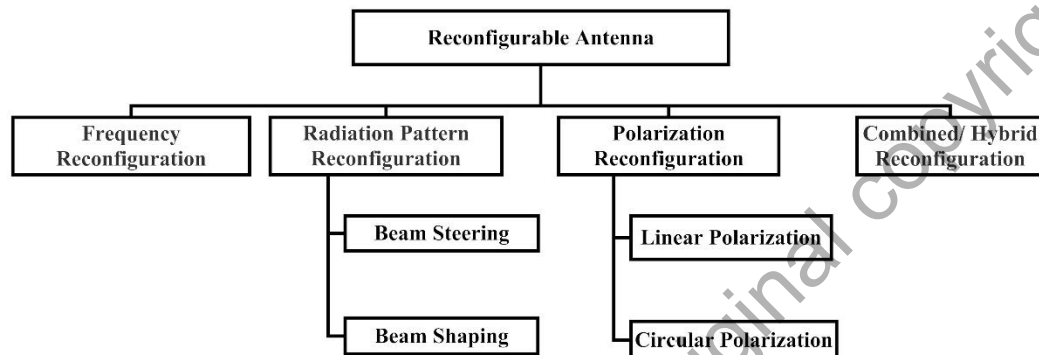

Figure 2.1: Reconfigurable Antenna Properties

2.3 Reconfigurable Antenna Switching Technology

Reconfigurable antenna is a radiating configuration that can modify its operating properties. Reconfigurable antenna can be divide into switching and non-switching technique as shown in Figure 2.2. The switch reconfiguration technique can be separated into electrical and optical switching. The non-switch reconfiguration technique is presents for movable (mechanical) and material change (C. G. Christodoulou, 2012 & J.T. Bernhard, 2007).

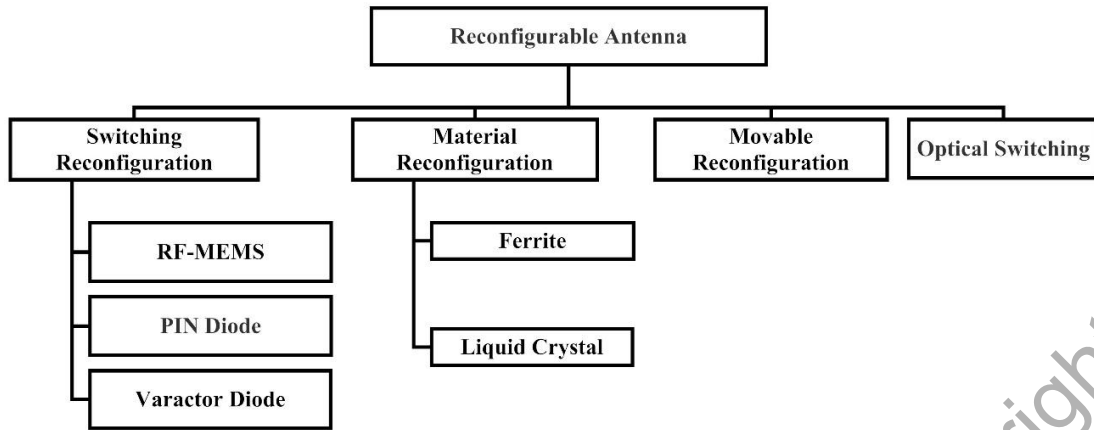

Figure 2.2: Reconfiguration Techniques

2.3.1 Switching Reconfiguration

The most conventional technology used by reconfigurable antennas is electrical switching. There are three switch types which are Radio-Frequency Micro-Electromechanical (RF-MEMS), PIN diodes and varactor diodes (C. G. Christodoulou, 2012). Generally, the PIN diode is easy to be controlled by a simple digital circuit, and perform in two conditions either ON or OFF. The configuration of a RF switch is to control current flow to the desired RF path. The selection of the PIN diode is based on the characteristics of the antenna, where different types of PIN diode have different types of switching speed, power level, insertion loss, reflection coefficient, isolation loss and sizes (C. G. Christodoulou, 2012 & J.T. Bernhard, 2007). Therefore, the researcher should consider the techniques of handling and soldering the PIN diode from avoid more complexity.

The varactor diode operates based on the changes of the capacitance value when the bias voltage is varied (C. G. Christodoulou, 2012 & J.T. Bernhard, 2007). However, the switching capability of PIN diodes and varactor diodes are good in terms speed of operation and ease of packaging compare to RF-MEMS switch (C. G. Christodoulou,

2012). RF-MEMS is a mechanically switches made on a substrate of silicon, quartz and glass. RF-MEMS can provide low power consumption, low insertion loss and high isolation. The disadvantage of the RF-MEMS switch is the cost because of the packaging process, but the use of RF-MEMS can enable the performance of a reconfigurable system much higher in terms of the beam steering and gain (D. Rodrigo & B. A. Cetiner 2011).

The performance of PIN diode is based on the insertion and isolation loss of the switch. Each conditions of the PIN diode changes the performance of reflection coefficient and transmission coefficient. The activation of switch in ON-condition leads to the maximum of the power transmission and transmission coefficient. Isolation loss defines OFF-conditions where the whole system is disconnected from power. The insertion and isolation loss can be calculated using Equation 2.1 and 2.2 respectively.

$$IL = 20 \log \left(1 + \frac{RS}{2Z_0} \right) \quad 2.1$$

$$ISO = 10 \log \left[1 + \left(\frac{1}{2wCsZ_0} \right) \right] \quad 2.2$$

2.3.2 Material Reconfiguration

The first non-switching reconfiguration is tunable material. It used a material to control the electromagnetic properties. This technique does not use any switching mechanism which focuses to tune in a particular location, but only using the structure of

the antenna. The tunable material can lead to high losses and degrade the performance of an antenna compare with other technologies. For these reasons, these techniques are not often used in reconfigurable antenna. The antenna can be configured by using ferrites or liquid crystals as substrate. The characteristics of the material changes based on relative electric permittivity or magnetic permeability. These changes can be used to implement reconfigurable antennas (D. M. Pozar, 1988 & A. Tagantsev, 2003).

2.3.3 Movable Reconfiguration

The second non-switching reconfiguration is movable and rotatable antennas. This reconfiguration used the basic forms of reconfigurable reconfiguration and the first has been implemented (J.-C. Chiao, 1999). By actuating over the antenna structure, it is possible to change its position, orientation and structure, and as a result the antenna properties are modified. There are few types actuation mechanisms are used in rotatable and moveable antenna where one of the elements is mechanical actuation using linear actuators and stepper motor (K. Daheshpour, 2010 & Y. Tawk, 2011). It most ideal technology for operating at high and low frequencies due to the size of the antenna where mechanical actuation becomes more efficient.

2.4 Radiation Pattern Reconfigurable Antenna

The radiation pattern of a reconfigurable antenna is based on the altering the current distribution. The important part of the radiation pattern is to maintain the input impedance while modifies the currents over the antenna. The basic radiation pattern techniques are shown in Figure 2.3.

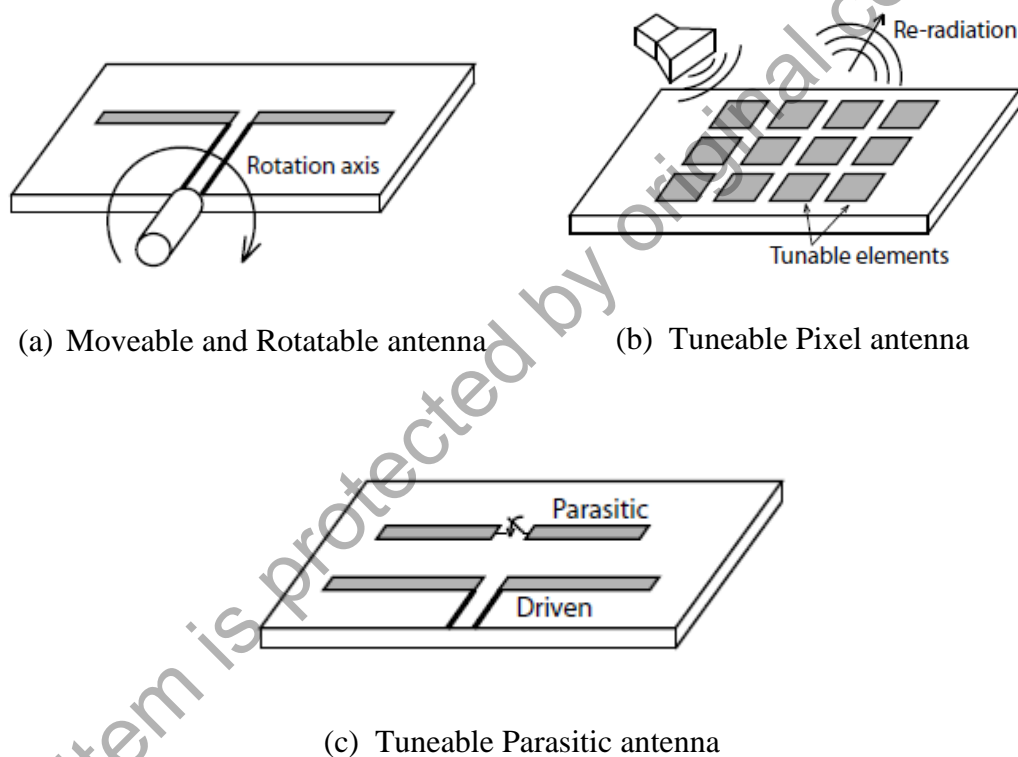

Figure 2.3: Types of Reconfigurable Radiation Pattern (D. Rodrigo,2014)

In the radiation pattern the moveable and rotatable antenna are simpler methods to reconfigure the antenna. This technique rotates the antenna structure to achieve the radiation pattern without affecting the reflection coefficient. Even though the techniques are simpler, but needs a bulky mechanical setup to adjust the antenna structure for the reconfiguration speed and power consumption. The most ideal

switching mechanism for the moveable antenna is RF-MEMS. The next method to reconfigure the radiation pattern is using switches or tunable parasitic elements. These methods have a significant effect over the current distribution without degrading the performance level. The tunable parasitic method is used widely to reconfigure the antenna radiation pattern.

The position of driven element should be located near to the parasitic elements other in order to have strong current distribution to modify the antenna pattern (M. Jusoh, 2014 & T. Sabapathy, 2015). To ensure a good impedance matching and current distribution the distance between driven element and parasitic elements are located based on $\lambda/2$ (M. Jusoh, 2014). Reconfigurable antenna used switching parasitic for radiation pattern has been studied a lot such as monopoles antenna (X. Yuan, 2012), microstrip antenna (M. Jusoh, 2014, T. Sabapathy, 2015 & D. Rodrigo, Y. Damgaci 2011) and slot antenna (S. Nair & M. J. Ammann, 2010).

The parasitic element can be placed on the top of the driven element at the suitable dielectric distance. However, the amount of parasitic elements is much higher compare to single layer parasitic element antenna. This approach follows the same concept as reconfigurable reflect arrays and lens arrays. The direction of the antenna beam is achieved by the phase of the re-radiated field of each element of array (P. Lotfi, 2016). Next concept provides the radiation pattern capabilities which are leaky-wave technology (R. O. Ouedraogo, 2011). By implementing switches in a strategic position in the antenna, it activates individually based on the conditions.

2.4.1 Previous Research on Reconfigurable Radiation Pattern Antenna

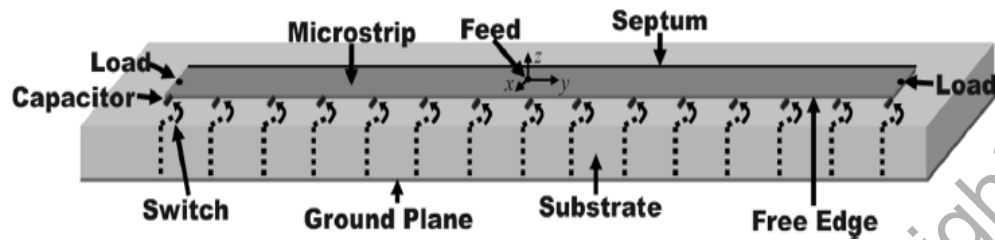

Figure 2.4: Structure of Microstrip Leaky-Wave Antenna (R. O. Ouedraogo, E. J. Rothwell, & B. J. Greetis, 2013)

Authors (R. O. Ouedraogo, E. J. Rothwell, & B. J. Greetis, 2011) have been described a half-width microstrip leaky-wave antenna with an electronically steerable as shown Figure 2.4. This antenna capability to steer more than 40 degrees and operating in the range of 5.8 GHz to 8 GHz. Moreover, this concept uses a larger number of switches which placed adjacent to the free space and connected to the ground plane. This can lead to high complexity for biasing mechanism since located in single layer. The can be steered to five different angles of -0° , -20° , -40° , -50° , -60° and -70° at certain PIN diode configurations.

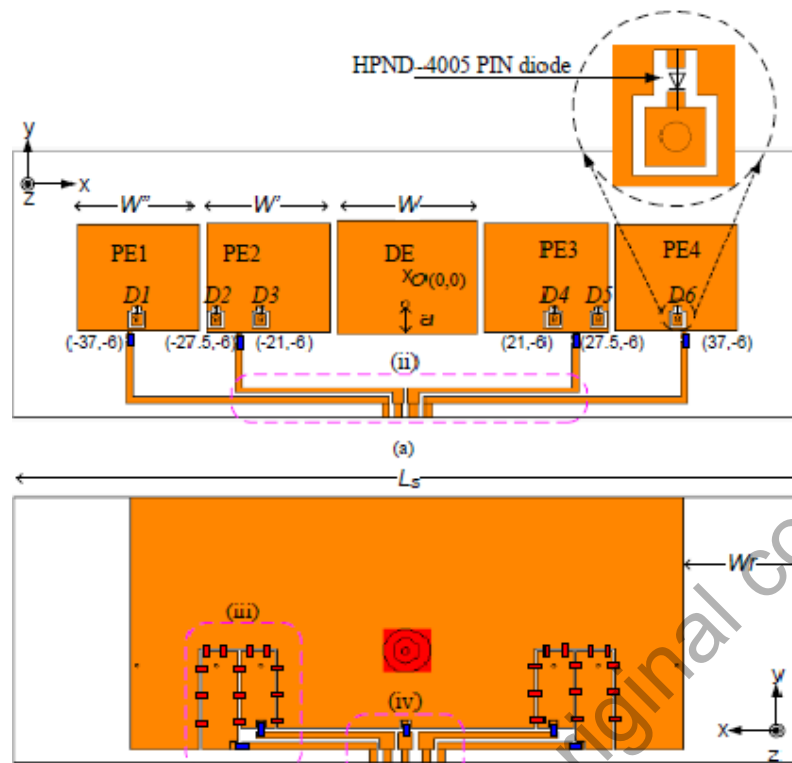

Figure 2.5: Structure of Yagi-Uda Patch Array Antenna (T. Sabapathy & R. B. Ahmad, 2015)

T. Sabapathy & R. B. Ahmad, 2015 proposes a reconfigurable array antenna with parasitic patches for beam steering application. This antenna operates at 5.8 GHz and capability to steer at -50° , -30° , 0° , 30° , and 50° degree with 7 dBi gain for each angle. The antenna structure consists of one driven and four parasitic elements with a gap of 1 mm. Each of the parasitic elements connect with HPND 4005 PIN diode. With the help of RF PIN diode, is able to steer towards the five desired direction. The author has proposed a new method of ground plane reduction to increase the steering performance level of the presented antenna, but involves with larger number of modifications for DC biasing operation.

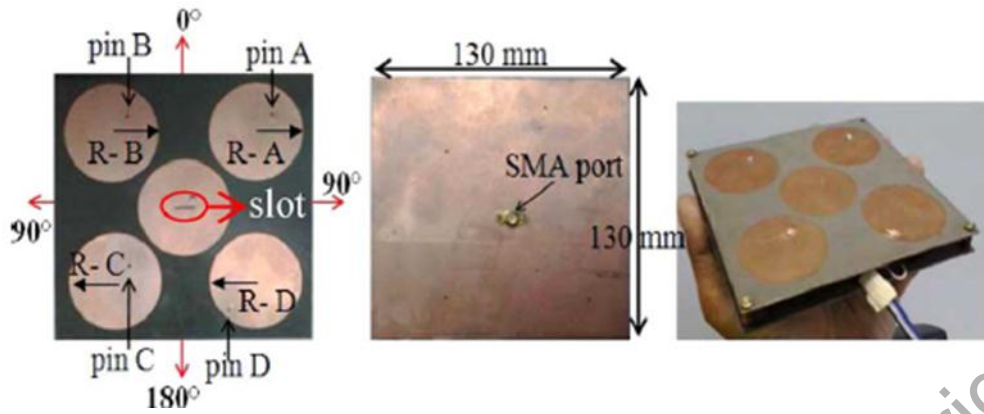

Figure 2.6: Structure of FPPA (M. Jusoh & T. Sabapathy, 2014)

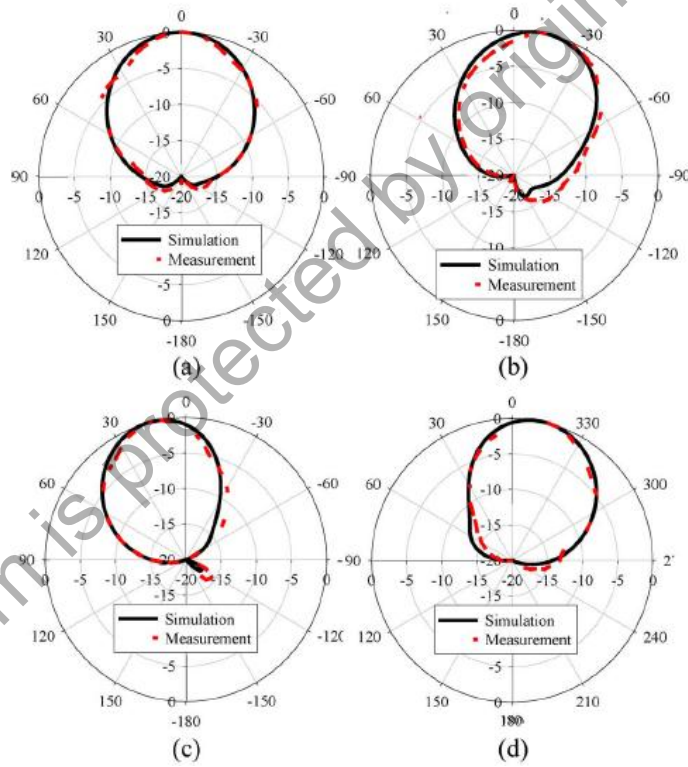

Figure 2.7: Measured and simulated radiation patterns of FPPA (M. Jusoh & T. Sabapathy, 2014)

A reconfigurable beam-forming of a four-parasitic element patch antenna for WIMAX application is presented in (M. Jusoh, T. Sabapathy, & M.R.Kamarudin, 2014). This antenna operates at 2.4 GHz and capability to steer at five different angles of 0° , 45° , 135° , 225° with an average gain of 8.2 dBi. The antenna structure consists of one driven and four parasitic elements that connect with BAR5002 PIN diode for RF switch mechanism. The driven elements perform as the radiator and the parasitic as a reflector or director based on the switching conditions.

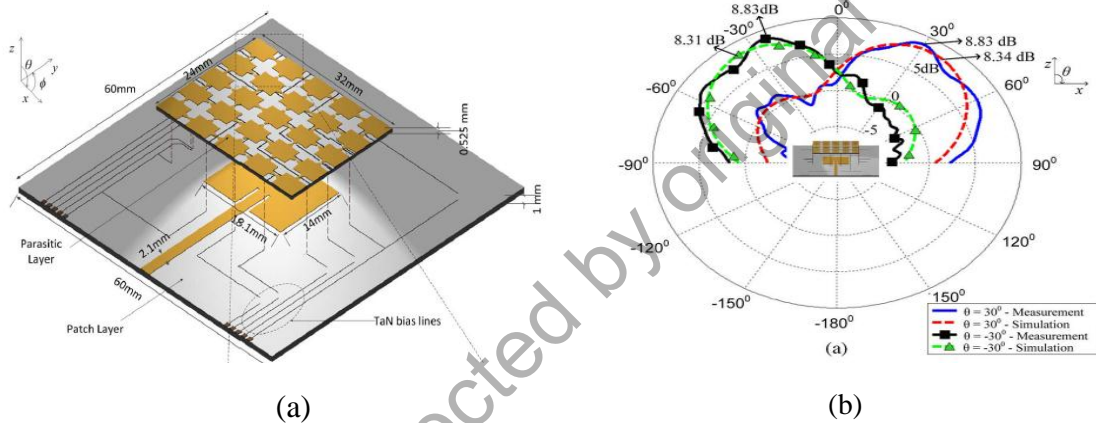

Figure 2.8: Multifunctional reconfigurable antenna (MRA) (a) Structure of (MRA), (b) Radiation patterns (X. Yuan, Z. Li & D. Rodrigo, 2012)

Figure 2.8 shows the multifunctional reconfigurable antenna (MRA) presented by (X. Yuan, Z. Li & D. Rodrigo, 2012). The antenna operates at 5.6 GHz and capability to steer the angle into three directions of -30° , 0° and 30° . The antenna consist of a driven element that fed by a microstrip feed line Of 50Ω impedance and parasitic elements of 5×5 rectangular-shaped. The parasitic elements are connected to MEMS switches with high-resistive DC bias lines. The EM energy from the driven element changes the parasitic element's properties of the antenna.

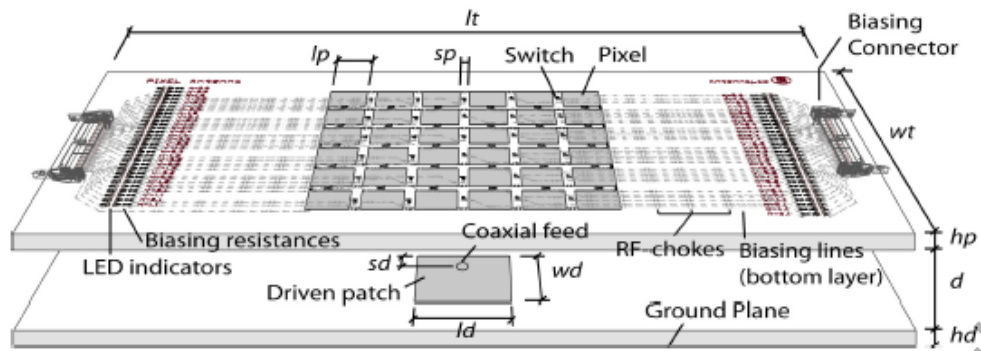

Figure 2.9: Structure of parasitic pixel layer antenna (D. Rodrigo & B. A. Cetiner, 2014)

D. Rodrigo & B. A. Cetiner, 2014 presented a reconfigurable antenna using parasitic pixel layer. These antennas consist of two layers which the bottom layer as driven element and top layer is the pixel structure. This antenna operates at 2.4 GHz and capability to steer at three different angles of -30° , 0° and 30° with an average gain of 6 dBi. The pixel structure consist of 6×6 pixels use large amount of PIN diode for switching mechanism which lead to high DC biasing. This design divides the biasing lines into one bias line for switch and two common DC –lines. All the pixels are interconnected by RF-chokes and set at DC voltage of 5 V. The anode of each PIN diode switch is connected to one pixel and its cathode is connected through a DC-block capacitor to the adjacent pixel. The biasing lines are located on the bottom side of the pixel structure with an LED indicator to monitor the switch conditions. However, the antenna requires high cost and high fabrication complexity, and may be difficult to maintain the performance of the antenna

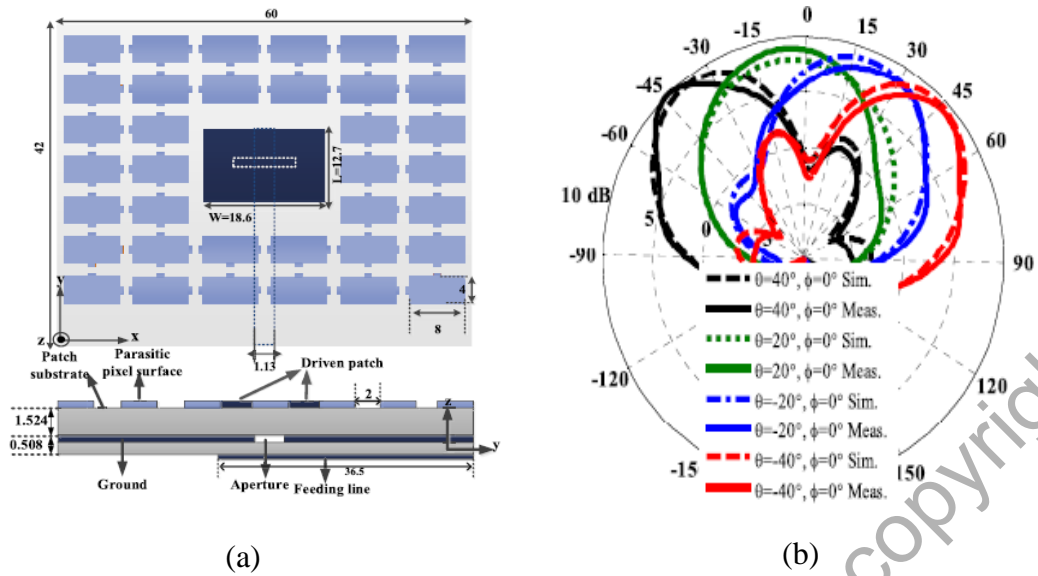

Figure 2.10: Planar patch driven element with rectangular grids (a) Radiator Pattern and (b) Structure of antenna (P. Lotfi, S. Soltani, & R. D. Murch, 2016)

P. Lotfi, S. Soltani, & R. D. Murch, 2016 presented a planar patch driven element with a rectangular grid of parasitic pixel elements in single layer. The antenna operating at 5.7 GHz and used aperture-fed. This antenna capable to steered the angle at -40° , -20° , 20° and 40° . The number parasitic elements apply for this designed is 36 with a usage of 54 switches. The gain and S11 obtain for this application is approximately 9.5 dB and -20 dB. Although the presented antenna manages to perform at four different directions, it shows high complexity and bulky at particular frequency.

2.5 Motivation for Present Research

The previous research shows clearly that various different techniques of work have been used on the reconfigurable antenna such as leaky-wave, parasitic and pixel concept. Each technique of a reconfigurable antenna has its own performance level and complexity which plays the fundamental role to determine the performance level of the antenna. In order to improve the capability of the antenna, different method has been used to minimize the complexity of the structure, technique of reconfiguration and improve in choosing the antenna material.

The literature survey shows that the reconfigurable parasitic antenna can improve the performance level of the reflection coefficient, gain and radiation pattern result based on the antenna modification for the application. The parasitic technique can be divided into single parameter configuration and pixel configuration. For single parameter consist of combining the driven element and parasitic element in the same layer. The pixel configuration consists of driven and pixel layer separately where the pixel structure will be located on the top layer of the driven layer. Parasitic antennas and pixel structure are the main concept of this research, which focuses on the implementation of parasitic antennas and pixel structure with a minimum number of switches to increase the beam steering performance of the antenna. These researches use a Yagi-Uda antenna concept as a reference which implements parasitic element to realize the reconfigurable radiation pattern. The Yagi-Uda antenna is consists of a single driven element, five elements of director and a single reflector. The mutual coupling between the driven element and the parasitic elements can improve the radiation pattern of the antenna.

CHAPTER 3: METHODOLOGY

3.1 Introduction

This research is divided into two stages. The first stage is the concept of the antenna structure. Later on, the EM of antenna will be perform using CST software. The next stage is presented the conceptual structure of the antenna with the measurement analysis.

This methodology part covered the overall research flow works. This chapter divides into five sections; a brief description of each section is given hereby. Section 3.2 presents the overall work flow. Followed by, section 3.3 and 3.4 which discusses the design specification of driven and parasitic antenna that include of the antenna material, feeding technique, switching technique and the capabilities of the antenna. Section 3.5 discusses the concept of pixel antenna structure, switching ability, lumped components, biasing lines and the combination of driven and pixel antenna. Finally, section 3.8 it is represented on the antenna fabrication process and following by section 3.9 on the measurement process.

3.2 Research Work Flow

All related works of reconfigurable parasitic antenna and conceptualization of pixel structure which focus on the application of beam steering pattern are reorganized. PIN Diode act as switching element to achieve the reconfiguration of the antenna. The previous ideas and concept, has been used as the improvement for the present antenna.

This reconfigurable antenna develops into three structure, such as driven, parasitic and pixel structure that based from the calculation analysis. The initial antenna design of the driven and parasitic structure is a circular patch shape. The next approach is the pixel structure. It develops from multi-element of square patches, where each pair of pixel patches is interconnected by an RF- switch.

This first approach of this design is developing driven structure in single layer that capable to operate at 9.5 GHz with acceptable return loss and gain. The next approach is combines the parasitic and driven structure in single layer, where the parasitic located at the right and left side of driven structure. The third approach is placed the pixel layer on the top layer of the driven and parasitic layer with an air gap between the layers. All the simulation is performed by CST software by generating the reflection coefficient, gain and radiation pattern.

Once achieve the optimal result from the simulation then all the antennas are fabricated using Taconic substrate with dielectric constant of 2.2. All the prototypes is tested and measured in KEYSIGHT EN5234 PNA-L Network Analyzer and Atenlab (OTA-500) Chamber in Universiti Teknologi MARA (UiTM) Shah Alam.