



**DESIGN AND DEVELOPMENT OF DC-DC SINGLE-  
ENDED PRIMARY INDUCTOR CONVERTER  
(SEPIC) FOR MAXIMUM PHOTOVOLTAIC POWER  
EXTRACTION**

by

**NURDAYANA HANIS BINTI MHD ASLAN  
(1632221993)**

A dissertation submitted in partial fulfillment of the requirements for the  
degree of Master of Science Electrical Power Engineering

**School of Electrical System  
UNIVERSITI MALAYSIA PERLIS**

2016

## ACKNOWLEDGEMENT

Alhamdulillah, I am grateful and thankful to Allah because of His bless, I have finally complete my Dissertation Project successfully. First of all, I would like to express many thanks and gratitude to my supervisor, Dr. Mohammad Faridun Naim bin Tajuddin for guiding me throughout the whole project period which starts at the beginning of the first semester and due at the end of the second semester during session 2016/2017. With his expertise, I was able to complete my project smoothly and on schedule. Without his guidance and knowledge in Power Electronics and Renewable Energy, I would not be able to finish the Dissertation Project on time. He has been given his best to ensure that I was able to understand the knowledge and experience gained while doing the project.

Finally yet importantly, thanks to all the persons who directly or indirectly contributed because their perspective and guidance helped greatly to point must in the right direction to complete this report. I also would like to dedicate a special appreciation to my beloved family for their support and encouragement. Not to forget, my appreciation also goes to A.T who shared a lot of knowledge, ideas and opinion throughout the completion of my project. Their help, advices and moral support do help me a lot in getting through the hard times while finishing the Dissertation Project.

## TABLE OF CONTENTS

	<b>PAGE</b>
<b>THESIS DECLARATION</b>	<b>ii</b>
<b>ACKNOWLEDGEMENT</b>	<b>iii</b>
<b>TABLE OF CONTENTS</b>	<b>iv</b>
<b>LIST OF FIGURES</b>	<b>viii</b>
<b>LIST OF TABLES</b>	<b>x</b>
<b>LIST OF ABBREVIATIONS</b>	<b>xi</b>
<b>LIST OF SYMBOLS</b>	<b>xii</b>
<b>ABSTRAK</b>	<b>Xiii</b>
<b>ABSTRACT</b>	<b>xiv</b>
<b>CHAPTER 1 INTRODUCTION</b>	
1.1 Project Background	1
1.2 Problem statement	2
1.3 Objective	4
1.4 Scope of Project	4
1.5 Project Outline	5
<b>CHAPTER 2 LITERATURE REVIEW</b>	
2.1 Introduction	6
2.2 Solar Photovoltaic Cell and Module	6
2.3 Series Connection of PV Cells	9

2.4	Parallel Connection of PV Cells	11
2.5	Maximum Power Point Tracker (MPPT) in Photovoltaic System	12
2.6	DC-DC Converter as a MPP Tracker	14
2.7	DC-DC SEPIC Converter	17
2.8	Previous Work	19
2.9	Summary	21

### **CHAPTER 3 METHODOLOGY**

3.1	Introduction	22
3.2	Flow of Project	23
3.3	Determination of the Operation Point Range	24
3.4	SEPIC Converter as the MPP Tracker	26
3.4.1	Duty Cycle Consideration	26
3.4.2	Inductor Selection	27
3.4.3	Power MOSFET Selection	28
3.4.4	Output Diode Selection	28
3.4.5	SEPIC Coupling Capacitor Selection	29
3.4.6	Output Capacitor Selection	30
3.4.7	Input Capacitor Selection	31
3.5	SEPIC Converter Design	32
3.5.1	Duty Cycle Consideration	33
3.5.2	Inductor Selection	33
3.5.3	MOSFET Selection	34
3.5.4	Diode Selection	34

3.5.5	Capacitor Selection	34
3.5.6	Final Design Specifications	36
3.6	Simulation Model	37
3.7	Hardware Development and Experimental Setup	37
3.8	Summary	39

## **CHAPTER 4 RESULTS AND DISCUSSION**

4.1	Introduction	41
4.2	Overall System Design	42
4.3	Simulation and Experimental Analysis	43
4.3.1	1000W/m <sup>2</sup> irradiance	46
4.4	SEPIC Converter Performance Analyses	52
4.4.1	Converter Efficiency	52
4.4.2	Converter Output Voltage Ripple	54
4.4.3	Converter Output Current Ripple	56
4.5	Summary	58

## **CHAPTER 5 CONCLUSION**

5.1	Summary	59
5.2	Future Work	60
5.3	Commercialization potential	60

<b>REFERENCE</b>	<b>62</b>
------------------	-----------

<b>APPENDICES</b>	<b>64</b>
-------------------	-----------

## LIST OF FIGURES

NO.		PAGE
1.1	PV module with DC-DC converter and MPPT	2
2.1	Photovoltaic Effect	7
2.2	Solar Photovoltaic	9
2.3	Series connection of cells	10
2.4	<i>I-V</i> characteristics of series connection	10
2.5	Parallel connection of cells	11
2.6	<i>I-V</i> characteristics of parallel connection	12
2.7	MPP across the <i>I-V</i> curve at different solar irradiance and temperature changes	13
2.8	The real <i>I-V</i> and <i>P-V</i> curves from the datasheet	14
2.9	PV module supplying a resistive load	14
2.10	Definition of the system operating point by the <i>I-V</i> and load intersection	15
2.11	<i>I-V</i> and load curves intersection for defining the PV system operating point	16
2.12	MPPT system	17
2.13	SEPIC converter circuit	18
2.14	Operational region of the <i>I-V</i> curve for SEPIC DC-DC converter	18
3.1	Flow chart	23
3.2	PV module supplying a resistive load	24
3.3	Load and generation curves intersection	25
3.4	PV module connected to a load through a DC-DC converter	25
3.5	Output Ripple Voltage	30

3.6	Simulation of PV module, SEPIC converter and load	37
3.7	SEPIC converter	38
3.8(a)	Gate driver	38
3.8(b)	DSP controller	38
3.9	PV simulator	38
3.10	Experimental setup	39
4.1	<i>I-V</i> curve characteristics of simulation at 1000W/m <sup>2</sup> irradiance	46
4.2	<i>I-V</i> curve characteristics of hardware experiment at 1000W/m <sup>2</sup> irradiance	46
4.3	<i>P-V</i> curve characteristics of simulation at 1000W/m <sup>2</sup> irradiance	47
4.4	<i>P-V</i> curve characteristics of hardware experiment at 1000W/m <sup>2</sup> irradiance	47
4.5	Hardware result of PV simulator for 0.1 duty cycle at 1000W/m <sup>2</sup> irradiance	48
4.6	Hardware result of PV simulator for 0.2 duty cycle at 1000W/m <sup>2</sup> irradiance	48
4.7	Hardware result of PV simulator for 0.3 duty cycle at 1000W/m <sup>2</sup> irradiance	48
4.8	Hardware result of PV simulator for 0.4 duty cycle at 1000W/m <sup>2</sup> irradiance	49
4.9	Hardware result of PV simulator for 0.5 duty cycle at 1000W/m <sup>2</sup> irradiance	49
4.10	Hardware result of PV simulator for 0.6 duty cycle at 1000W/m <sup>2</sup> irradiance	49
4.11	Hardware result of PV simulator for 0.64 duty cycle at 1000W/m <sup>2</sup> irradiance	50
4.12	Hardware result of PV simulator for 0.7 duty cycle at 1000W/m <sup>2</sup> irradiance	50
4.13	Hardware result of PV simulator for 0.8 duty cycle at 1000W/m <sup>2</sup> irradiance	50

4.14	Hardware result of PV simulator for 0.9 duty cycle at 1000W/m <sup>2</sup> irradiance	51
4.138	3D plot between efficiency, irradiance and duty cycle of simulation	53
4.139	3D plot between efficiency, irradiance and duty cycle of hardware experiment	53
4.140	3D plot between output voltage ripple, irradiance and duty cycle of simulation	55
4.141	3D plot between output voltage ripple, irradiance and duty cycle of hardware experiment	55
4.142	3D plot between output current ripple, irradiance and duty cycle of simulation	57
4.143	3D plot between output current ripple, irradiance and duty cycle of hardware experiment	57

©This item is protected by original copyright

## LIST OF TABLES

NO.		PAGE
3.1	PV module specifications	32
3.2	All parameters	36
4.1	PV module specifications	42
4.2	MPP and <i>I-P-V</i> for all irradiance	45

©This item is protected by original copyright

## LIST OF ABBREVIATIONS

DC	direct current
PV	photovoltaic
SEPIC	Single-Ended Primary Inductor Converter
MPPT	maximum power point tracker
MPP	maximum power point
$I$ - $V$	current-voltage
$P$ - $V$	power-voltage
C1	capacitor 1
C2	capacitor 2
L1	inductor 1
L2	inductor 2

©This item is protected by original copyright

## LIST OF SYMBOLS

°	degree
%	percentage
°C	degree Celcius
s	second
Hz	Hertz

©This item is protected by original copyright

# **Reka Bentuk dan Pembangunan DC-DC Penukar (SEPIC) Induktor Utama Berhujung Tunggal untuk Pengekstrakan Kuasa Fotovoltan Maksimum**

## **ABSTRAK**

Baru-baru ini, penjana kuasa fotovoltan telah menjadi salah satu sumber tenaga boleh diperbaharui paling boleh diharapkan yang mana digunakan dalam sistem penjana elektrik. Prestasi sistem fotovoltan paling penting untuk penjejakan titik kuasa maksimum (MPPT) dan benar-benar bergantung pada sinaran serta suhu tenaga suria. Untuk mendapatkan kuasa maksimum dari satu sistem fotovoltan, satu kecekapan tinggi penukar DC-DC diinginkan dan dengan kuat bergantung berdasarkan input modul PV. Penukar DC-DC SEPIC diajukan sebagai pengawal mengesan titik kuasa maksimum oleh eksperimen simulasi dan perkakasan. Tidak seperti penukar buck-boost, penukar SEPIC ialah satu pengeluaran bukan sonsang kerana ia menggunakan kapasitor siri memisahkan input dari poutput dan memberikan pilihan untuk mempunyai sama ada keluaran lebih rendah atau tinggi voltan berbanding dengan voltan masukan. Penukar buck-boost mempunyai satu arus masukan terputus biasa yang menyebabkan ia kehilangan lebih kuasa disebabkan oleh pensuisan masukan. Selain itu, penukar SEPIC mempunyai arus masukan yang lebih cekap dan baik berbanding penukar buck-boost. Kedua-dua hasil percubaan simulasi dan perkakasan dibuktikan berdasarkan hubungan antara modul PV, penukar SEPIC dan beban dengan mempelbagaikan sinaran dan kitar tugas tetapi pada suhu 25°C yang malar. Karakteristik lengkung I-V dan P-V untuk kedua-dua simulasi dan eksperimen perkakasan menunjukkan kelainan dalam soal susunan kitar tugas dari 0.1 hingga 0.9 dan persamaan MPP untuk semua sinaran. MPP untuk semua sinaran tercapai dengan kitar tugas yang berbeza oleh penukar SEPIC. Apabila sinaran meningkat dari 100W/m<sup>2</sup> kepada 1000W/m<sup>2</sup>, titik kuasa maksimum (MPP) juga meningkat sekata. Persembahan analisis menunjukkan penukar SEPIC sesuai untuk diguna pakai oleh perancang PV untuk mengesan titik kuasa maksimum untuk mana-mana kesinaran suria.

## Design and Development of DC-DC Single-Ended Primary Inductor Converter (SEPIC) For Maximum Photovoltaic Power Extraction

### ABSTRACT

Recently, photovoltaic power generation has been one of the most dependable renewable energy sources which are used in electrical generation system. The performance of the photovoltaic system is the most significant for the maximum power point tracking (MPPT) and is absolutely relied upon the irradiance and temperature of the solar energy. To obtain a maximum power from a photovoltaic system, a high efficiency of DC-DC converter is desired and strongly dependent based on the input of the PV module. A DC-DC SEPIC converter is proposed as the controller to track the maximum power point (MPP) by simulation and hardware experiment. Unlike buck-boost converter, SEPIC converter is a non-inverted output as it uses a series capacitor to separate the input from the output and provides the choices to have either higher or lower output voltage compared to the input voltage. The buck-boost converter has a discontinuous input current characteristic that roots to a more power losses due to input switching. Besides that, SEPIC converter has contended input current and better efficiency compared to buck-boost converter. Both simulation and hardware experiment results are proved based on the connections between PV module, SEPIC converter and load by varying the irradiance and duty cycle but at constant 25°C temperature. The curves characteristic of  $I-V$  and  $P-V$  for both simulation and hardware experiment shows a difference in terms of duty cycle arrangement from 0.1 to 0.9 and similarities for the MPP for all irradiance. The MPP for all irradiance achieved by varies the duty cycle of the SEPIC converter. As the irradiance increases from 100W/m<sup>2</sup> to 1000W/m<sup>2</sup>, the point of the maximum power increases constantly. The analysis shows that SEPIC converter is essential to be used by PV planner to track a maximum power point for any solar irradiance.

# CHAPTER 1

## INTRODUCTION

### 1.1 Project Background

In the last few decades, photovoltaic (PV) power generation has been one of the most dependable renewable energy sources which are used in electrical generation system. PV system is a direct current (DC) of power source that generates a low power capacity for many applications. PV power generation is mostly affected by certain elements such as the efficiency of the PV panel, the efficiency of the converter and also the efficiency of the maximum power point tracker (MPPT).

Presently, the efficiency of solar panels is less than 20% (Maglin JR, RameshR, & VaigundamoorthiM, 2014). Furthermore, this 20% efficiency is taken without taking into consideration the effect of environmental changes. The efficiency of the PV module can drop further due to other factors such as solar panel temperature, irradiance level and variation in load. Generally, a solar panel is rated at specific irradiance and temperature level of  $1000 \text{ W/m}^2$  and  $25^\circ\text{C}$  respectively. In order to extract the maximum power from the PV system, it is imperative to operate the panel at its optimum power point.

In order to ensure that the photovoltaic modules always extracting the maximum power, a specific circuit known as Maximum Power Point Tracker (MPPT) is normally employed. In most common applications, the MPPT is a DC-DC converter controlled through a strategy that allows imposing the photovoltaic module operation point on the Maximum Power Point (MPP) or close to it.

Figure 1.1 shows the block diagram of PV module with DC-DC converter and its control circuit. The aim of this work is to design and develop the MPPT which is based on Single-Ended Primary Inductor Converter (SEPIC). SEPIC converter is selected based on its high capability to track the MPP in both voltage and current region of the  $I$ - $V$  curve.

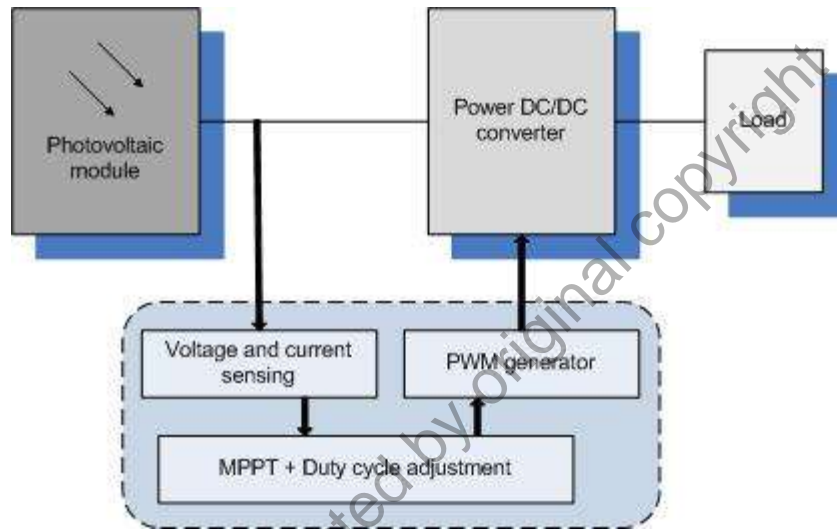

Figure 1.1: PV module with DC-DC converter and MPPT.

## 1.2 Problem statement

Usually, Maximum Power Point Tracker (MPPT) is engrossed to ascertain the extraction of maximum power from a PV system. By interposing a DC-DC converter in between the PV generator and the load, MPPT is achieved. Hence, the operating point of the system can be assured at the MPP by changing the converter's duty cycle. In reality, the power point tracking becomes problematic as the MPP need to be varied with irradiance and temperature.

Nonetheless, the continuous operation at the MPP can only be obtained with a DC-DC converter with simultaneous Buck and Boost characteristics. Buck-boost, Cuk and SEPIC converters are acknowledged as the most appropriate for MPPT application. Unlike buck-boost converter, SEPIC converter is a non-inverted output such it uses a series capacitor to separate the input from output. The buck and buck-boost converters have a discontinuous input current characteristic that roots to a more power losses due to input switching.

Generally, the boost converter has higher efficiency compared to SEPIC converter. The output voltage is always larger than the input which causes inflexibility in maximum power extraction. SEPIC converter provides the choices to have either higher or lower output voltage compared to the input voltage. Besides that, SEPIC converter has contended input current and better efficiency compared to buck-boost converter (Commonly used Power and Converter Equations).

There is lack of understanding in the literature on the performance of SEPIC converter. However, this work attempted to use the SEPIC converter for analyzing its capability in extracting the maximum output power because of the other Cuk and Zeta converter's inverted output.

### 1.3 Objective

The objectives of this project are:

- i. To design the DC-DC SEPIC converter as MPP tracker
- ii. To develop the DC-DC SEPIC converter hardware for photovoltaic (PV) power extraction
- iii. To analyze the capability of DC-DC SEPIC converter in extracting maximum output power for various environmental conditions

### 1.4 Scope of Project

The scopes of this project are:

- To analyze and study the characteristic and performance of the SEPIC converter for photovoltaic system
- The SEPIC converter is designed based on specific calculated parameters
- The SEPIC converter is enable using MATLAB simulation and hardware experiment setup
- The input of the PV simulator is based on the standard PV module datasheet from NB Solar Power Company at  $P_{max}=90W$ ,  $V_{mpp}=18.1V$  and  $I_{mpp}=4.98A$
- To compare the MPP and duty cycle at irradiances  $100W/m^2$  to  $1000W/m^2$  for both simulation and hardware experiment

## 1.5 Project Outline

This report starts with Chapter 1 which represents a general introduction of the development of SEPIC converter and maximum photovoltaic power extraction. Besides, this chapter also explains the problem statements, objectives and scope of the project.

Next, Chapter 2 provides a literature review that included some explanations and elaborations regarding the research information as well finding on previous works. The sources of the contents are from papers, journals, websites, articles, books and etc.

Then, Chapter 3 describes the methodology that involved the simulation of MATLAB and hardware experimental setup. The methodology of this project is also shown in a flowchart form.

Subsequently, Chapter 4 presents and analyzed the results of the project that have been obtained. Furthermore, a comparisons between simulation and hardware experiments are included in this project is shown in this chapter.

Finally, Chapter 5 gives a summary and conclusion of overall achievements with several recommendations for future improvements of this project.

## CHAPTER 2

### LITERATURE REVIEW

#### 2.1 Introduction

This chapter explains the several researches that are related to this project. This project is about SEPIC converter to be applied as maximum power point tracker. The MPPT is an absolute device that can extract a maximum output power from a photovoltaic module system.

#### 2.2 Solar Photovoltaic Cell and Module

Solar cells produce electricity directly from the conversion of sunlight. Usually, solar cells are used for emergency lamps, calculators and watches. These semiconductors are related in making solar cells where a solar cell is an essential to a large surface area of P-N junction. The N-type material is kept thin to allow light to pass through the P-N junction. When sun rays or radiant energy is absorbed by these materials, the solar energy will release the electrons from their atoms to produce electricity by allowing the electrons to flow through the material. The conversion process from light (photons) to electricity (voltage) is called the phenomenon of 'Photovoltaic Effect'. Figure 2.1 shows the phenomenon of Photovoltaic Effect.

Inside the depletion region of P-N junction, the electrical current generations are passed through as the electron from the N-type silicon dispersed into the P-type material. A

free electron and a hole are created as soon as the photon of light immersed by the atoms in the N-type silicon discharges an electron. Both the free electron and a hole had abundant energy to ascent out of the depletion region. The electrons will flow through the wire when the cathode (N-type) is connected to the anode (P-type). A flow of electrical current is created as the free electron is centralized to the positive charge of the P-type material and travels through the external load. Meanwhile, the formation of hole by the discharged electron is attracted to the negative charge of N-type material and dispersed to back electrical contact. As the electron enters the P-type silicon from the back electrical contact, it merges with the hole revive the electrical neutrality (“How Photovoltaic Cells Generate Electricity,”).

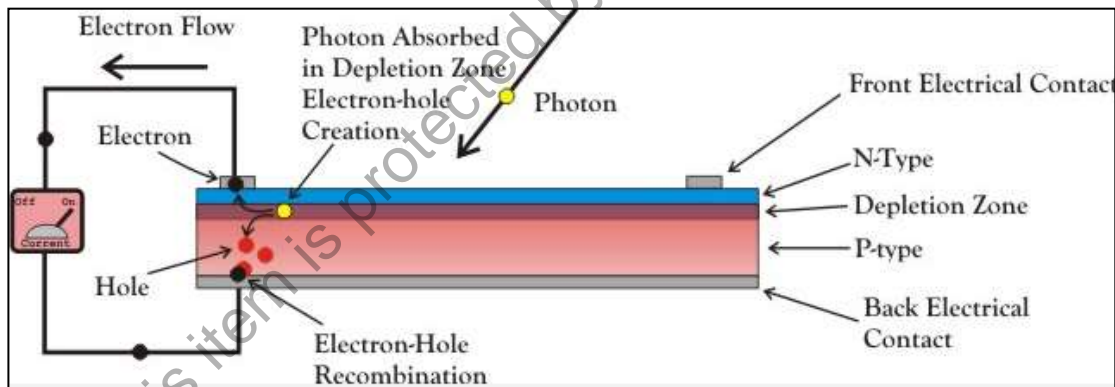

Figure 2.1: Photovoltaic Effect.

Typically, solar modules are made of the combination of solar cells that consists about 40 cells; a number of these modules are mounted in PV arrays that can measure up to several meters on a side. These flat-plate PV arrays can be mounted at a fixed angle facing south, or they can be mounted on a tracking device that follows the sun, allowing them to capture the most sunlight over the course of a day. Several connected PV arrays can

provide enough power for a household; for large electric utility or industrial applications, hundreds of arrays can be interconnected to form a single, large PV system (“Photovoltaic Systems - Renewable Energy World,”).

Thin film solar cells use layers of semiconductor materials only a few micrometers thick. Some solar cells are designed to operate with concentrated sunlight. These cells are built into concentrating collectors to focus the sunlight onto the cells. The performance of a solar cell is measured in terms of its efficiency by turning sunlight into electricity. Only sunlight of certain energies will work efficiently to create electricity, and much of it is reflected or absorbed by the materials that build the cell. Because of this, a typical commercial solar cell has an efficiency of 18% about one-sixth of the sunlight striking the cell generates electricity. A low efficiency means that larger arrays are needed. Improving solar cell efficiencies is an important goal for the whole photovoltaic industry. The first solar cells, built in the 1950s, had efficiencies of less than 4%. The PV modules output itself are affected by irradiance (G) and temperature (T) (“Photovoltaic Systems - Renewable Energy World,”). Figure 2.2 shows the solar photovoltaic installed in many countries including Germany, Japan, and the United States. These photovoltaic power generating stations are springing up in ‘sun belt’ areas all over the world. Sometimes the PV stations are joined with windmill generators so that power may be generated under a variety of weather conditions (Glennon, R., Reeves, 2010; “Photovoltaic Discoveries,”).



Figure 2.2: Solar Photovoltaic (“Photovoltaic Discoveries”).

### 2.3 Series Connection of PV Cells

The incremental of PV cells in series can be made by the overall voltage of the PV panel. Thus, the group connection of cells in series is called string. In a series connection, the current is remained constant, whereas the individual voltage produce by each of the PV cell will be added together. This will increase the voltage in series connection. On the other hand, the current is equal to the current produced by individual PV cells. Figure 2.3 shows example of series connection of PV cells.

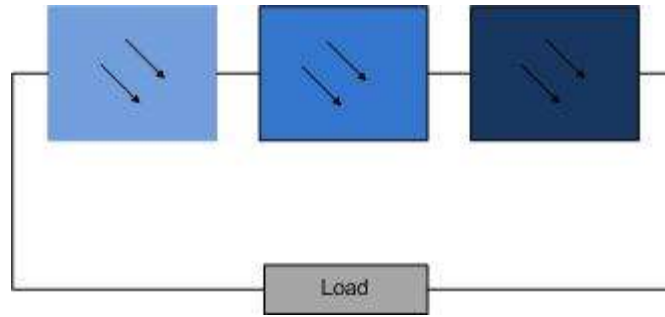

Figure 2.3: Series connection of cells.

From Figure 2.3, total output voltage is three times the voltage of the individual cell and the current will remain constant. Figure 2.4 shows the  $I$ - $V$  characteristics of series connection. The cell current conditions should be aligned with respect to the string because the string will operating at lower current level when output current of one cell is lower than the other remaining cells. Hence, the remaining cells will not achieve the optimum power points.

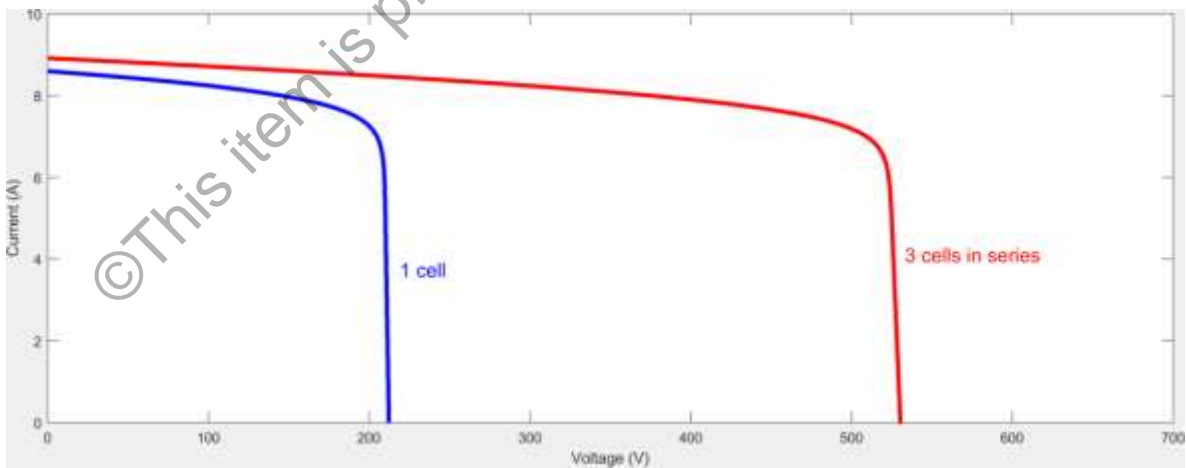

Figure 2.4:  $I$ - $V$  characteristics of series connection.

## 2.4 Parallel Connection of PV Cells

In parallel connection of PV cells, it is a vice versa to series connection as the output of current and voltage will be different. The current will be increase while the voltage is remained constant. In this connection, the output current of individual cells is added together to produce total output current. Otherwise, the output voltage is equal to output voltage of individual cell. In a string, the output current is increasing, while the output voltage is equal to individual cell. Figure 2.5 shows the parallel connection of PV cells.

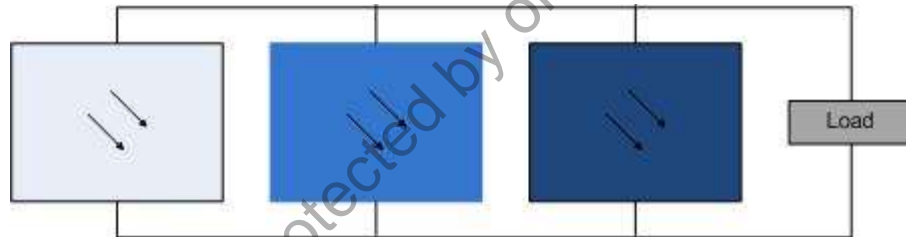

Figure 2.5: Parallel connection of cells.

The maximum power point is affected when the operating of the cells in parallel connection is different. This happens the same with series connection as the total output power is reduced when the individual cell operating voltage is different. Thus, some interruptions will happen on maximum power point of the remaining cells. Figure 2.6 show the  $I$ - $V$  characteristics of parallel connection.