



**PARAMETER EXTRACTION OF PV MODULES  
USING PARTICLE SWARM OPTIMIZATION**

**MARUWAN MOHAMMED KHALLEEFFAH ALQISHAT**

**(1632222115)**

A thesis submitted in fulfillment of the requirements for the degree of

Master of Science (Program) / Doctor of Philosophy

**School of Electrical System**

**UNIVERSITI MALAYSIA PERLIS**

2016

## ACKNOWLEDGMENT

First of for most, my praise and gratitude to Allah S.W.T for the strength given to me to complete my Master's Degree in Electrical Power Engineering.

I would like to acknowledge my project supervisor, Dr. Mohd Faridun for his constant guidance, valuable expert suggestions and encouragement throughout the project.

I would also like to extend my thankfulness to all my friends and UniMAP staff for their support and willingness to help me out during various stages of my project.

Last but not least, special thanks to my beloved family for their patience, moral support and motivation during my masters project.

## TABLE OF CONTENTS

<b>THESIS DECLARATION</b>	<b>II</b>
<b>ACKNOWLEDGMENT</b>	<b>ERROR! BOOKMARK NOT DEFINED.</b>
<b>TABLE OF CONTENTS</b>	<b>IV</b>
<b>LIST OF TABLES</b>	<b>VII</b>
<b>LIST OF FIGURES</b>	<b>VIII</b>
<b>LIST OF SYMBOLS</b>	<b>X</b>
<b>ABSTRAK</b>	<b>XI</b>
<b>ABSTRACT</b>	<b>XII</b>
<b>CHAPTER 1 INTRODUCTION TO STUDY</b>	<b>1</b>
1.1 Introduction	1
1.2 Problem Statement	4
1.3 Aims and Objectives	6
1.3.1 Aims of Research	6
1.3.2 Objectives	6
1.4 Scope of Work	7
1.5 Research Question	8
1.6 Thesis Outline	8
<b>CHAPTER 2 LITERATURE REVIEW</b>	<b>10</b>
2.1 Introduction	10
2.2 Photovoltaic Modelling Review	12
2.3 Extraction of PV module Parameters Review	18

2.4	I-V Characteristics for Photovoltaic (PV) Cell	23
2.5	Environmental and Cell Parameters Consideration in PV cell Model	25
2.6	Summary	26
<b>CHAPTER 3 DESIGN AND METHODOLOGY</b>		<b>28</b>
3.1	Introduction	28
3.2	Photovoltaic (PV) Module	29
3.2.1	Solar Energy Conversion	31
3.2.2	Temperatures Influence on Photovoltaic Cells Performance	35
3.2.3	PV Array	36
3.2.4	Particle Swarm Optimization (PSO) Algorithm	37
3.3	Modeling of Photovoltaic System and PSO algorithm	41
3.3.1	Single Diode Model	41
3.3.2	Modeling of PSO PV Module Parameter Extraction	44
3.4	Using the Model	47
3.5	Code Snippet	49
<b>CHAPTER 4 RESULT AND DISCUSSION</b>		<b>50</b>
4.1	Introduction	50
4.2	Photovoltaic System Result	51
4.3	Parameters Extraction of Photovoltaic System and Optimization using Particle Swarm Optimization	61
4.4	Relative Error Calculation	64

4.5 Comparative Curve Comparison Method	66
4.6 Comparison of extracted system ofRs, Rsh, Iph Io and aof PSO algorithm and M. G. Villalva et al.withexisting system (MATLAB)MATLAB ISOTECT 1STH-215-P module	69
<b>CHAPTER 5 CONCLUSION AND RECOMMENDATION</b>	<b>71</b>
5.1 Conclusion	71
5.2 Summary	72
5.3 Future Recommendation	75
<b>REFERENCES</b>	<b>77</b>
<b>APPENDIX A</b>	<b>81</b>
<b>APPENDIX B</b>	<b>82</b>
<b>APPENDIX C</b>	<b>83</b>
<b>APPENDIX D</b>	<b>84</b>
<b>APPENDIX E</b>	<b>85</b>
<b>APPENDIX F</b>	<b>86</b>

## LIST OF TABLES

NO.	PAGE
Table 4.1:MATLAB ISOTECH 1STH-215-P, PSO Solar Module and M. G. Villalva et. al. System Module table result when Nominal value is 1000	53
Table 4.2:MATLAB ISOTECH 1STH-215-P, PSO Solar Module and M. G. Villalva et. al. System Module table result when Nominal value is 800	54
Table 4.3:MATLAB ISOTECH 1STH-215-P, PSO Solar Module and M. G. Villalva et. al. System Module table result when Nominal value is 600	55
Table 4.4:MATLAB ISOTECH 1STH-215-P, PSO Solar Module and M. G. Villalva et. al. System Module table result when Nominal value is 400	56
Table 4.5:MATLAB ISOTECH 1STH-215-P, PSO Solar Module and M. G. Villalva et. al. System Module table result when Nominal value is 200	57
Table 4.6:Adjustable parameters of the proposed PSO algorithm	61
Table 4.7:PSO Search Space Definition	62
Table 4.8:Optimal parameters and predicted value generated by PSO	62
Table 4.9: Calculated Relative Error with mean absolute deviation, MAD	66
Table 4.10: Comparison table of $R_s$ , $R_{sh}$ , $I_{ph}$ $I_o$ and $a$ of all all system	70
Table 4.11:Deviation result of PSO system,MarceloGradellaVillalva system and existing MATLAB solar module	70

## LIST OF FIGURES

NO.	PAGE
Figure 2.1: The applications of PV systems	12
Figure 2.2: Photovoltaic cell array model Source: Salmi et al. (2012)	13
Figure 2.3: I-V characteristics curve sample result data of KC200GT	14
Figure 2.4: Solar panel characteristic curves	15
Figure 2.5: PV cell modeled as diode circuit	16
Figure 2.6: PV module comprises of parallel branch along with series connection	18
Figure 2.7: I-V Curve for PV cell	24
Figure 3.1: Design flowchart of parameter extraction of PV modules using particle swarm optimization	29
Figure 3.2: Dark body radiation spectral distribution and the radiation of sun on earth surface	32
Figure 3.3: Global incident radiation and direct incident radiation on sun facing tilted 37 degree	33
Figure 3.4: PV cell Structure	37
Figure 3.5: Equivalent circuit diagram of a single diode photovoltaic (PV) cell	42
Figure 3.6: Velocity formation scheme and position updated	46
Figure 3.7: PV module parameter extraction using PSO flowchart	48
Figure 4.1: I-V Curve for MATLAB ISOTECH 1STH - 215 - P Solar Module	58
Figure 4.2: P-V Curve for MATLAB ISOTECH 1STH - 215 - P Solar Module	58
Figure 4.3: I-V Curve for PSO Solar Module	59
Figure 4.4: P-V Curve for PSO Solar Module	59

Figure 4.5: I-V Curve for M. G. Villalva et. al. System	60
Figure 4.6: PV Curve for M. G. Villalva et. al. System	60
Figure 4.7: Convergence process curve of PSO algorithm of single diode model	64
Figure 4.8: Comparative Curve for Curve for MATLAB ISOTECT 1STH-215-P, PSO Solar Module and M. G. Villalva et. al. System at nominal irradiance value of 1000	67
Figure 4.9: Comparative Curve for Curve for MATLAB ISOTECT 1STH-215-P, PSO Solar Module and M. G. Villalva et. al. System at nominal irradiance value of 800	67
Figure 4.10: Comparative Curve for Curve for MATLAB ISOTECT 1STH-215-P, PSO Solar Module and M. G. Villalva et. al. System at nominal irradiance value of 600	68
Figure 4.11: Comparative Curve for Curve for MATLAB ISOTECT 1STH-215-P, PSO Solar Module and M. G. Villalva et. al. System at nominal irradiance value of 400	68
Figure 4.12: Comparative Curve for Curve for MATLAB ISOTECT 1STH-215-P, PSO Solar Module and M. G. Villalva et. al. System at nominal irradiance value of 200	69

## LIST OF SYMBOLS

$T_{top}$	Cell operating temperature in
$T_{ref}$	Cell temperature at 25°C
$T_{ref,}$	Cell temperature at 25°C
$I_{rs}$	Diode reversed saturation current at $T_{op}$
$I_s, I_o$	Diode reversed saturation current
$I_{sh}$	Shunt current
$I_d$	Diode forward current
$V, V_{pk}$	Generated output voltage from the photovoltaic (PV) panel, V
$V_{mp}$	Maximum PV module voltage
$I_{mp}$	Maximum PV module current
$a, n$	Diode ideality factor
$C$	Total number of cells in a PV panel
$N_p, N_s$	Total number of PV panel in parallel and series
$E_g$	Band-gap energy of the cell at 1.12eV
$V_t$	Terminal voltage
$k$	Boltzmann's constant at 1.38e-23
$q$	Electron Charge constant at 1.6e-19 C
$R_{sh}$	Shunt resistance
$R_s$	Series resistance
$I_{ph}, I_{pv}$	Phase current
$V_{oc}$	Open circuit voltage (Solar panel)

# Pengekstrakan Parameter Modul Photovoltan Menggunakan Particle Swarm

## Optimization

### ABSTRAK

Pemanasan global dan kempen pencemaran atmosfera telah menyebabkan permintaan global terhadap tenaga bersih bagi penjana kuasa, oleh itu keperluan terhadap tenaga elektrik meningkat setiap hari, keperluan ini telah membawa penyelidik untuk mengoptimumkan tenaga boleh baharu seperti tenaga photovoltan. Walau bagaimanapun, kebanyakan pendekatan penyelidikan tenaga boleh baharu adalah berfokus kepada teknik pengoptimuman photovoltan. Untuk pembangunan sistem photovoltan bereka bentuk yang pantas, simulasi yang cekap dan tepat adalah penting, alat simulator direka bentuk untuk pelbagai tujuan seperti menjejaki titik kuasa maksimum, untuk menganggarkan kecekapan sistem dan memahami hubungan di antara sistem Photovoltaic dan penukar kuasa. Kawasan penjejakan titik kuasa maksimum dan anggaran kecekapan adalah sangat penting dalam reka bentuk modul PV kerana ia adalah berguna untuk menentukan jenis penukar yang diperlukan dan bagaimana penukar ini perlu direka bentuk supaya sistem ini memindahkan kuasa optimum kepada beban. Walau bagaimanapun, memahami hubungan di antara sistem photovoltan dan penukar membantu untuk menentukan keseluruhan hasil tenaga. PV simulator terdiri daripada unsur yang berbeza, di kalangan semua, elemen yang penting adalah model sel PV. Oleh itu, ia menjadi wajib untuk mempunyai model ketepatan tinggi yang boleh meniru dan mencontohi sifat-sifat dan tingkah laku sel PV sesuai dengan keluk arus dan voltan (I-V) yang diukur dan untuk menganggarkan data di bawah kondisi yang berbeza. Tesis ini membangunkan peningkatan untuk pemodelan sel PV menggunakan teknik algoritma 'Particle Swarm Optimization' (PSO) di mana teknik ini tidak seperti teknik pengoptimuman yang lain. Lima parameter yang berbeza telah dimasukkan ke dalam pertimbangan ini adalah  $R_{sh}$ ,  $R_s$ ,  $I_{ph}$ ,  $I_o$  dan  $a$ . Kajian ramalan parameter ini juga dipertimbangkan bersama-sama dengan maklumat yang diberikan oleh pengeluar helian data mengenai modul PV. PSO algoritma serentak mengira semua parameter model pada keadaan standard ujian (STO) dan pengesahan sistem itu berdasarkan module PV. Fokus kajian ini adalah kepada pengekstrakan parameter module PV yang dioptimumkan menggunakan algoritma PSO. Kajian juga dilakukan bagi membangunkan pemodelan sel PV menggunakan diod tunggal litar setara dan ekuasinya, parameter yang tidak diketahui akan diramal dengan PSO, analisis sistem dan pengesahan data. Perkembangan ini adalah kebanyakannya pada pengiraan dan perisian dilaksanakan menggunakan MATLAB. Hasil akhir kajian ini adalah berdasarkan analisis I-V dan P-V kepada sistem yang dibangunkan.

Kata kunci: photovoltan, permodulan, algoritma PSO, tenaga solar, ekstrak parameter, rintangan, suhu.

# Parameter Extraction of PV Modules Using Particle Swarm Optimization

## ABSTRACT

Global warming and atmospheric pollution campaign has cause a global demand of clean energy for power generation, therefore needs for electrical energy increase daily, this need has led researcher to continue working on optimizing renewable energy for power generation such of photovoltaic energy. However, lots of renewable energy research approach recently is mostly on photovoltaic optimization techniques, For reliable and fast design of photoelectric system development, an efficient and precise simulate is essential, simulator tools is practically design for many purposes such as maximum power point region prediction, to estimate the system efficiency and to understand the relationship between Photovoltaic system and power converters. Maximum power point region tracking and efficiency estimation is very crucial in PV module design as it is useful to determine the type of converter requires and how this converter have to design in order for the system to transfer optimum power to load. However, understand the relationship between photovoltaic system and converters helps to determine overall energy yield prediction. PV simulator comprises of different element, among all, the most important element is the PV cell model itself. Therefore, it becomes compulsory to have high precision model that can simulate and emulate the properties and behavior of PV cells such as fits the measured I-V curve and to estimate data under different conditions. The thesis developed an improvement for PV cell modeling using particle swarm optimization techniques unlike other optimization techniques approach by other researchers. Five different parameters was put into consideration these are  $R_{sh}$ ,  $R_s$ ,  $I_{ph}$ ,  $I_o$  and  $a$  while the approach study allow the predictions of these parameters along with information provided by manufacturer datasheet regarding PV module. PSO algorithm approach simultaneously computes all model parameters at standard test condition (STC) and the system validation was based on existing polycrystalline module. In this development, major techniques include maximum power point tracking, parameters extraction, and design of DC-DC power converter and improvement of inverters. This study focus on parameters extraction for PV module optimization using particle swarm optimization (PSO) algorithm. Study investigate in related work, development include the modelling of PV cell using single diode equivalent circuit and its equation, unknown parameters predictions with PSO, system analysis and data validation. This development was mostly on calculation and software based implemented using MATLAB while the final outcomes present I-V and P-V analysis of the developed system.

**Keywords:** Photovoltaic, Modelling, PSO Algorithm, Solar Energy, Parameters Extraction, Resistance, Temperature.

# CHAPTER 1

## INTRODUCTION TO STUDY

### 1.1 Introduction

The needs of electrical energy increasing daily while more than 60% of the world electricity supply rely on fossil fuel till date, this is advisable for future power generation due to production constrain such as air pollution and global warming, having this has encourage the development of optimization of renewable energy for electricity such as photovoltaic energy (Askarzadeh&Rezazadeh, 2013).

Renewable energy resources receive ever-increasing attention over years as provision and consumption of energy faces challenging situations. Among these energy sources, solar energy is one of the most popular renewable energy because of its availability and ease of utilization. Solar energy converters transform the sun radiating energy to controlled heat cycles or electrical energy which are further utilized or stored in different platforms. Photovoltaic (PV) modules key element is solar to electrical energy converters and it is known that efficient design of energy transforming systems requires precise parameters identification and modeling of PV systems. Therefore, an important track of research is dedicated to characterization and parameter extraction of PV modules. Some of the main reported articles on parameter extraction of the PV module are briefly reviewed here.

Photovoltaic module has known to have a long term economic benefit due it low cost of maintenance and almost zero pollution, this has made the request of PV module to increase it become the most recent popular source of renewable energy. Implementation of PV module is relatively expensive at initial stage, however, advancement in fabrication technology cost and usage of high precision equipment has brought down the cost of production, though they still found to be expensive for short run power supply.

PV module do have few limitation compare to fossil fuel as it output depends on solar radiation, these need to improve which is while the model of PV cell simulator is required in order to ensure the optimum design of the system prior their installation while simulator reliability often depend on the precision of the PV cell itself.

Output of PV cell is a non-linear I-V characteristics which varies periodically due to effect internal and external effect such as resistance, temperature and irradiance, the primary objective of the thesis is to estimate the non-linear behavior of photovoltaic cell model and to emulate PV module electrical behavior.

Common approach is to determine and fit the experimental I-V data under different operation conditions using single, double diode or more diode equivalent circuit type having Rp-Model and Rs-Model.

Therefore, project research focus is more to characterization and parameters extraction for photovoltaic modules, the study reveal related work on renewable energy parameters extraction, there are two main type of PV cell modeling, these are single diode type or double diode type, in this current work, model selection is known be serve as important aspect for parameters extraction, single diode type is approach here, while the

design of current circuit models reflects the existing knowledge about the physical behavior of the PV modules.

For single diode R-p model implementation, there is needs to determine various parameters such as  $R_{sh}$ ,  $R_s$ ,  $I_{ph}$ ,  $I_o$  and  $a$ , that is shunt resistance, series resistance and phase current, diode saturated current module and ideal factor respectively. However, these parameters can't easily determine or solve explicitly due to transcendental nature of model. Further method to determine parameters approach using bisection and Newton Raphson to compute the model parameters.

Other sophisticated parameters estimation is the utilization of particle swarm optimization (PSO) algorithm which is the primary focus of this thesis. It is an evolutionary algorithm that is known for its ability to search for global optimum parameter in a search space regardless of initial parameters value. However, other works as prove PSO algorithm to be more accurate and efficient for parameters estimation.

Single model type does facilitate parameters extraction procedure and has lot of benefit due to its simplicity and easy to analyze compare with double diode type. Thus, design and model accuracy rely on quality of resultant to the point over the I-V graph of the module. Parameter extraction techniques for PV systems can be divided into two broad categories which are analytical and numerical extraction approaches (Ishaque, Salam, Mekhilef & Shamsudin, 2012).

Analytical modeling needs information about some key points over the I-V characteristic curve of the PV modules. Main key points include maximum power point, short-circuit current and open-circuit voltage. To fit the data to a model, analytical methods

put more emphasize on these key points. Authors in (Ishaque& Salam, 2011) recommended the use of analytical approach along with two diode circuit model to extract parameters of PV modules. A study in (Li, Ji, Li, Wei, Li & Shi, 2011) suggested the use of analytic approach for parameter extraction of the PV module with single-diode circuit. Basically these methods are curve-fitting algorithms, which require several runs of computations to obtain the best fit given the experimental data of the PV module.

This study aims at providing an alternative solution by providing an efficient optimization-based strategy for constructing a model for PV module one-diode circuit model using particle swarm optimization techniques for parameters extraction while model development uses MATLAB software.

## 1.2 Problem Statement

The PV module modeling basically includes the estimation of the non-linear I–V characteristics curve. Throughout the years, the circuit based approach has been generally used to describe the PV module. Among these models, single diode RP-model has been the most generally utilized equivalent circuit because of its simplicity and accuracy.

Because of the PV module current equation that is transcendental in nature, there is needs to determine various parameters such as  $R_{sh}$ ,  $R_s$ ,  $I_{ph}$ ,  $I_o$  and  $a$ , that is shunt resistance, series resistance and phase current, diode saturated current module and ideal factor respectively. Out of these, lone  $I_{ph}$  and  $I_o$  can be easily calculate (Villalva, Gazoli & Ruppert Filho, 2009). The rest of the parameters such as  $a$ ,  $R_{sh}$  and  $R_s$ , usually resolved numerically.

These typically include iterative process utilizing numerical strategies, for example, Newton Raphson (Villalva et al., 2009). Thus,  $a$ ,  $R_{sh}$  and  $R_s$ , can't be computed simultaneously alongside  $I_{ph}$  and  $I_o$  for a specific environmental condition that is, temperature and irradiance.

Evolution algorithm (EA) procedures have increased much consideration because of its capacity to handle nonlinear condition without requiring subsidiaries data. It is a stochastic improvement technique that seems to be extremely effective in enhancing and optimizing real value multi-modal objective function. Considering the numerous points of interest of PSO, this work proposes a strategy to simultaneously estimate  $R_{sh}$ ,  $R_s$ ,  $I_{ph}$ ,  $I_o'$  and  $a$ , that is shunt resistance, series resistance and phase current, diode saturated current module and ideal factor respectively.

PV power system as a source for converting the main source of solar energy to electrical power has motivated the researchers to propose various systems to manipulate such source as to produce renewable energy. Despite this, ensuring an accurate conversation of solar energy using current systems comes with high initial cost. Research has revealed that a proper system design for converting solar energy into electrical power could provide better efficiency (Qin & Kimball, 2011; Zhang, Zhu, Liu & Ramakrishna, 2012; Ye, Wang & Xu, 2009).

In addition, the accuracy of current systems designed for processing PV module is associated with the accuracy of the solar cell/module models along with the method utilized to estimate the model's parameters. With this in mind, it can be summated that current problem is mostly projected to choosing model that impose similar characteristics of solar

modules at all operating conditions. Since both circuit based single diode and the two-diode are considered to impose high level of complexity and cost, a cost effective and accurate modeling technique is still needed. As such, the research aims at providing an efficient optimization-based strategy for constructing a model for PV module.

### **1.3 Aims and Objectives**

#### **1.3.1 Aims of Research**

A set of points on the I-V curve of the PV module is given for different operating points, precise modeling of the PV module requires estimation of the unknown parameters in such a way that, the model could provide a reasonable fit to the measured data set. Based on this, the research formulated the following objectives:

#### **1.3.2 Objectives**

The research objectives stated as follow:

- 1) To develop an efficient optimization-based strategy for constructing a model for PV module.
- 2) To develop model validation tools to help assess the validity and preciseness of the obtained model given the experimental data.
- 3) To assess the capabilities and limitations of single diode model in providing an exact model of PV module.

## 1.4 Scope of Work

In order to achieve the objective of this study, the research directions are limited to the following scope:

- Evolutionary algorithms are utilized for parameter extraction of the PV module. The intuition behind this, is that these methods performs well in optimization-based problem where analytical solutions are hard to derive.
- Particle swarm optimization (PSO) is the selected method among evolutionary algorithms to extract the unknown parameters. It is known that among evolutionary algorithms, PSO performs better than simulated annealing and genetic algorithms. Several articles report application of PSO to parameter identification of PV modules. A PSO-based algorithm is presented in (H. Qin and J. W. Kimball, 2011)with reported precise outcome over wide temperature and solar irradiation range. The strategy in (Ye et al., 2009) utilizes PSO for parameter extraction with single and two diode circuit models and also compares the performance with genetic algorithms. Superior performance of PSO is observed by the authors compared to GA scheme.
- In this work it is assumed that single diode model is used as the basic circuit model. Ideal single diode model of a PV model consists of a current source in parallel to a diode. A more practical single diode model contains series and parallel resistance elements, this also depending on the temperature, irradiation and operating conditions of the solar cell, different characteristic curves can be obtained from a generic model. Hence, several parameters should be extracted in the proposed single-diode model.

## **1.5 Research Question**

- 1) How to design the environmental and cell parameters of PV module?
- 2) What type of PV module should be analyzed and what is the possible method for optimization?
- 3) How to use particle swarm optimization techniques for parameters extraction?
- 4) How to relate particles with PV module parameters?
- 5) How to find unknown parameters and obtain I-V and P-V curve?
- 6) How to find the possible error between original system I-V characteristics and optimization I-V characteristics?
- 7) How to model all derived equations using MATLAB software and provide a usable PV model?

## **1.6 Thesis Outline**

This section presents the outline of the all chapters.

### **Chapter 1: Introduction**

This is the general introduction which provide the basic insight the entire project, this describe the focus of the project and possible questions that need to be answered upon the completion of the project, it also provide basic requirement that helps to complete the project, these include the project aim and objective, research question, scope of study, problem of research .

## **Chapter 2: Intellectual Literature Review**

These section of the paper work consist of several related works and development approach by different researchers, it also discuss possible outcome for the project development such as the I-V curve and explain methods that has been used for parameters extraction and other techniques that a PV system can be optimize.

## **Chapter 3: Methodology**

This section provide all necessary idea, design, mathematical equation and required information for the final development , this include the analysis of PV parameters such as voltage, current, air mass, spectral analysis, temperature and others. It also consist of the final development of PV module and PSO algorithm that is done via MATLAB software

## **Chapter 4: Result and Discussion**

The result approach two major set of data, these include the final simulation modeling result of 215PPolycrystalline Modules and system optimization using PSO algorithm. This section describe the project achievement while graphs like I-V curve, P-V curve are all illustrated and the relative error of the system was calculated.

## **Chapter 5: Conclusion and Future Recommendation**

This section conclude the study by confirmed that, the proposed method can obtain better and higher parameter precision under several condition such as partial shading, solar insolation and unexpected environmental temperature factors and present the possible future work that includes stability, power control process, power quality, transient analysis, storage capability and fault detection protocol.

## CHAPTER 2

### LITERATURE REVIEW

#### 2.1 Introduction

Photovoltaic system comprise of several component, the most important component of all is solar cell, therefore it become necessary to determine solar cell parameters via theoretical or experimental data for design and evaluation of solar cells. For quality performance and quality assessment of solar cells, it is required to decide the exact parameters.

Besides, the model parameters are usually related mechanism that acts within solar cell, mostly internal physical properties. Over decades, a few techniques have been recommended for this reason while most of these extraction techniques utilizes similar strategies and can be comprehensively segregate into two different groups. One of these major approach is curve iterative or curve fitting strategy or numerical approach which based on approximation and considers selected element of the attributes where some parameters might be irrelevant or negligible, giving approximate result of each parameter. These techniques comprises of a different methods like vary of temperature, data extraction from single illumination (I-V) curve with optimization techniques and estimation of illuminated I-V characteristics at various light intensities. Another method is the (Ortiz-Conde & Sánchez, 2005; Yadir, Benhmida, Sidki, Assaid&Khaidar, 2009).

Photovoltaic is identified as the process converting solar energy into direct current electricity. This can be achieved by using semiconducting materials that detect the potential

effect of the photovoltaic (Macabebe, Sheppard & van Dyk, 2011). The applications of photovoltaic in different power systems can be grouped into two categories; Stand-alone system (also referred to as offgrid) and grid linked system (also referred to as on-grid).

Stand-alone system is typically incorporated with another energy source in order to empower the constancy of the power system. This can be found in the use of wind energy or power generator that is known as hybrid system. The main aspects that distinguish the two systems is the storage through which the produced power energy is ultimately stored in special batteries linked to the off-grid system (Zagrouba, Sellami, Bouaïcha&Ksouri, 2010). On the other hand, the public grid utility is considered to help provide a reliable space for keeping the excessive created energy from on-grid system(Hejri, Mokhtari, Azizian, Ghandhari & Söder, 2014). However, the utilization of on-grid systems is commonly seen in different countries due to its role in providing incentives ways to convert energy sources. Figure2.1 shows the current domains of using photovoltaic systems to provide energy sources for different power systems.

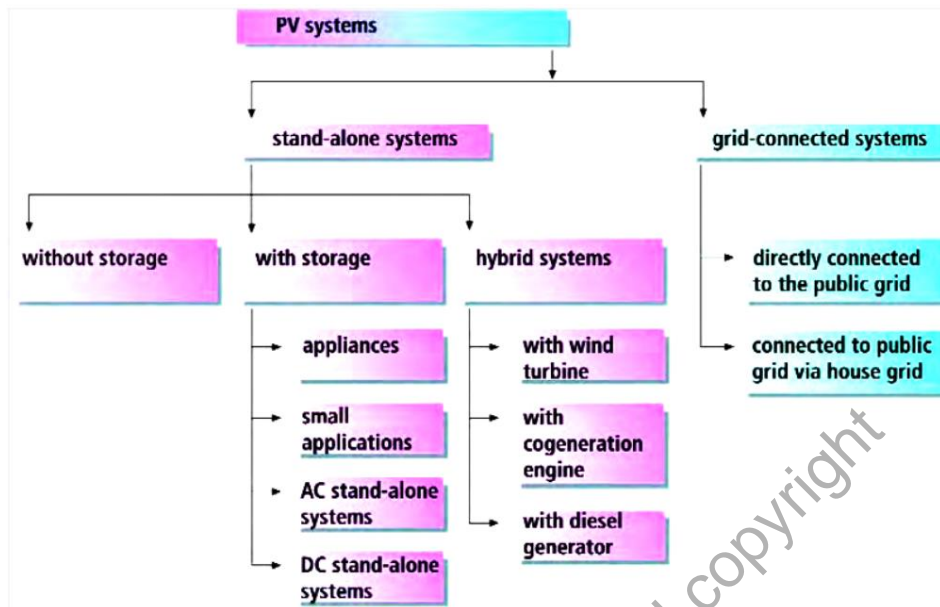

Figure 2.1: The applications of PV systems

## 2.2 Photovoltaic Modelling Review

Most PV model are mathematical equation and preferably describe the equivalent circuit of solar cell configuration with single or multiple diode illustration, however work describe in (Salmi et al.,2012) provide a single diode equivalent circuit which include diode in series, shunt resistor and series resistor, this is a Simulink based model which also allow the prediction of the natural behavior of photovoltaic cell.

Several study were carried out, such as variation of shunt resistance and effect of varying of reverse saturation current to PV module while the complete physical behavior of PV module found to have more relationship to the phase current, reverse saturation current, series resistor and shunt resistor. Study also include the effect of solar radiation while result achieved indicated that, PV cell current have a direct relationship or proportionality to solar

radiation. Therefore voltage found to increase by 50mV with increase in solar radiation between  $400 \text{ W/m}^2$  to  $1000 \text{ W/m}^2$  Salmi et al. (2012).

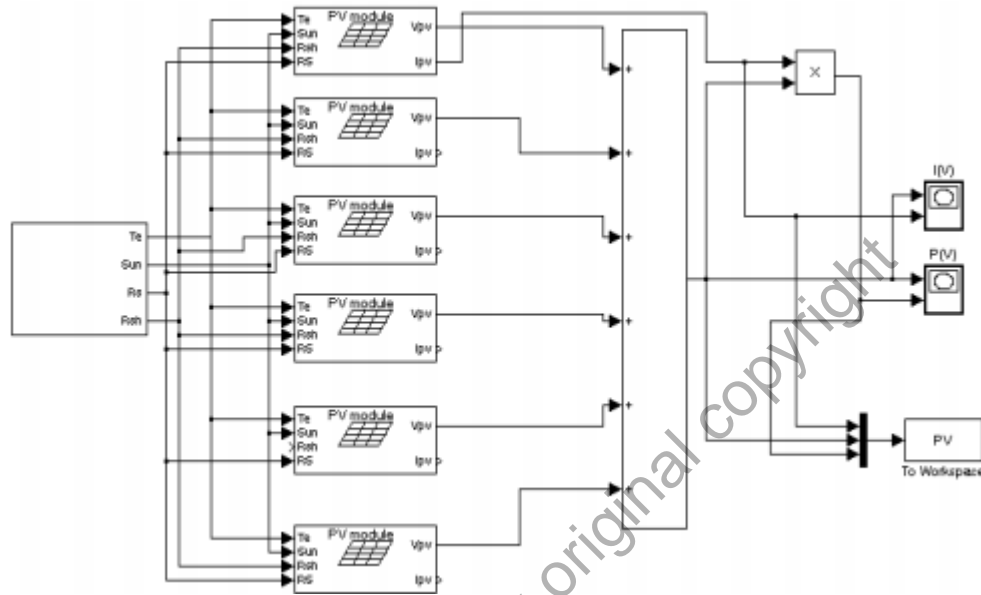

Figure 2.2: Photovoltaic cell array model  
Source: Salmi et al. (2012)

Therefore, if solar radiation could produce promising energy and could convert into electricity using solar cell, that is, for each environmental condition of solar energy collection and electricity conversion, there is an operating point or maximum power output on V-I characteristics of PV system, this is a point where maximum power output is achievable, therefore, at maximum power point of solar cell, the efficiency of the system could maximize with several algorithm, maximum power point tracking algorithm application proposed and design in (Esrām & Chapman, 2007; Blázquez-Sanz, & Morales-Ruiz, 2010) while simple simulation and modelling of solar panel with Simulink/MATLAB approach by Park, Kim, Cho and Shin (2014), this approach used a simple mathematical model and calculate unknown PV parameters such as diode current