



# **Comparative Study of Switching Strategies for Cascaded H-Bridge Multilevel Inverter**

by

**Usman Bashir Tayab  
(1432221160)**

A dissertation submitted in the partial fulfillment requirements for the  
degree of Master of Science (Electrical Power Engineering)

**School of Electrical System Engineering  
UNIVERSITI MALAYSIA PERLIS**

2014

## ACKNOWLEDGEMENT

All praises and thanks are to Allah, the Lord of the world, the most Beneficent, the most Merciful for helping me to accomplish this work.

I am beholden to a number of people, who supported me to carry out this work. First and foremost, my heartily profound thank you, gratitude and appreciation to my supervisor, Dr. Leong Jenn Hwai, for his supervision, encouragement, help, guidance and support throughout the period of this project. My deeply grateful is for his ample understanding, consideration and tolerance to my family conditions especially during the writing up period. His invaluable technical advices, ideas and suggestions were truly inspirational, and the exceptional effort he spent on reviewing this project has led to the successful completion of this work.

My greatest appreciation to Mr. Mohammad Aziuddin Yusof for his valuable friendship, fruitful talks, helpful suggestions and advices on the issues encountered in the project.

Very special thank to my family for their patience, understanding and encouragement during the different phases of my work. They spared no effort until this work comes to existence.

## TABLE OF CONTENTS

	<b>Page</b>
<b>DISSERTATION DECLARATION</b>	i
<b>ACKNOWLEDGEMENT</b>	ii
<b>TABLE OF CONTENTS</b>	iii
<b>LIST OF TABLES</b>	vi
<b>LIST OF FIGURES</b>	viii
<b>LIST OF ABBREVIATIONS</b>	xv
<b>ABSTRAK</b>	xvi
<b>ABSTRACT</b>	xvii
<b>CHAPTER 1 INTRODUCTION</b>	
1.1 Background	1
1.2 Problem Statement	3
1.3 Objectives	4
1.4 Scope of Project	4
1.5 Dissertation Synopsis	5
<b>CHAPTER 2 LITERATURE REVIEW</b>	
2.1 Introduction	6
2.2 Diode-clamped Multilevel Inverter	7
2.2.1 Advantages of Diode-clamped Multilevel Inverter	9
2.2.2 Disadvantages of Diode-clamped Multilevel Inverter	10
2.2.3 Applications of Diode-clamped Multilevel Inverter	10

2.3	Flying-capacitor Multilevel Inverter	11
2.3.1	Advantages of Flying-capacitor Multilevel Inverter	14
2.3.2	Disadvantages of Flying-capacitor Multilevel Inverter	15
2.3.3	Applications of Flying-capacitor Multilevel Inverter	15
2.4	Cascaded H-bridge Multilevel Inverter	16
2.4.1	Advantages of Cascaded H-bridge Multilevel Inverter	18
2.4.2	Disadvantages of Cascaded H-bridge Multilevel Inverter	18
2.4.3	Applications of Cascaded H-bridge Multilevel Inverter	19
2.5	Comparison Between Diode-Clamped, Flying-Capacitor and Cascaded H-bridge Multilevel Inverters	19
2.6	Motivation	20
<b>CHAPTER 3 RESEARCH METHODOLOGY</b>		
3.1	Principal of Operation of Cascaded H-bridge Multilevel Inverter	23
3.2	Flow Chart of Project Activities	32
3.3	Power Factor	34
3.4	Switching Control Strategies	35
3.4.1	Switching Strategy A	36
3.4.2	Switching Strategy B	36
3.4.3	Switching Strategy C	37
3.4.4	Switching Strategy D	37
3.5	3-level Cascaded H-bridge Multilevel Inverter	38
3.6	5-level Cascaded H-bridge Multilevel Inverter	38
3.7	7-level Cascaded H-bridge Multilevel Inverter	39
3.8	9-level Cascaded H-bridge Multilevel Inverter	40
3.9	11-level Cascaded H-bridge Multilevel Inverter	41

3.10	13-level Cascaded H-bridge Multilevel Inverter	42
3.11	15-level Cascaded H-bridge Multilevel Inverter	44
<b>CHAPTER 4 RESULTS AND DISCUSSIONS</b>		
4.1	Introduction	46
4.2	Simulation Results	46
4.2.1	3-level Cascaded H-bridge Multilevel Inverter	47
4.2.2	5-level Cascaded H-bridge Multilevel Inverter	54
4.2.3	7-level Cascaded H-bridge Multilevel Inverter	61
4.2.4	9-level Cascaded H-bridge Multilevel Inverter	68
4.2.5	11-level Cascaded H-bridge Multilevel Inverter	75
4.2.6	13-level Cascaded H-bridge Multilevel Inverter	82
4.2.7	15-level Cascaded H-bridge Multilevel Inverter	89
4.3	Relationship Between THD and Number of Levels	96
4.4	Relationship Between THD and Power Factor	98
<b>CHAPTER 5 CONCLUSION AND RECOMMENDATIONS</b>		
5.1	Conclusion	102
5.2	Recommendation for Future Work	103
<b>REFERENCES</b>		104
<b>APPENDICES</b>		
<b>APPENDIX A: Gantt Chart for Project</b>		

## LIST OF TABLES

No.		Page
2.1	Switching States of 5-level Diode-clamped Multilevel Inverter	8
2.2	Switching States of 5-level Flying-capacitor Multilevel Inverter	13
2.3	Switching States of 5-level Cascaded H-bridge Multilevel Inverter	17
2.4	Comparison of Multilevel Inverter	19
3.1	Comparison of Current Flow Between Resistive Load and Inductive Load in Cascaded H-bridge Multilevel Inverter	25
3.2	Parameters Value at Different Power Factor	34
3.3	Switching Angles for 3-level Cascaded H-bridge Multilevel Inverter	38
3.4	Switching Angles for 5-level Cascaded H-bridge Multilevel Inverter	39
3.5	Switching Angles for 7-level Cascaded H-bridge Multilevel Inverter	40
3.6	Switching Angles for 9-level Cascaded H-bridge Multilevel Inverter	41
3.7	Switching Angles for 11-level Cascaded H-bridge Multilevel Inverter	42
3.8	Switching Angles for 13-level Cascaded H-bridge Multilevel Inverter	43
3.9	Switching Angles for 15-level Cascaded H-bridge Multilevel Inverter	45
4.1(a)	Voltage THD for 3-level Cascaded H-bridge Multilevel Inverter	54
4.1(b)	Current THD for 3-level Cascaded H-bridge Multilevel Inverter	54
4.2(a)	Voltage THD for 5-level Cascaded H-bridge Multilevel Inverter	61
4.2(b)	Current THD for 5-level Cascaded H-bridge Multilevel Inverter	61
4.3(a)	Voltage THD for 7-level Cascaded H-bridge Multilevel Inverter	68
4.3(b)	Current THD for 7-level Cascaded H-bridge Multilevel Inverter	68
4.4(a)	Voltage THD for 9-level Cascaded H-bridge Multilevel Inverter	75

4.4(b)	Current THD for 9-level Cascaded H-bridge Multilevel Inverter	75
4.5(a)	Voltage THD for 11-level Cascaded H-bridge Multilevel Inverter	82
4.5(b)	Current THD for 11-level Cascaded H-bridge Multilevel Inverter	82
4.6(a)	Voltage THD for 13-level Cascaded H-bridge Multilevel Inverter	89
4.6(b)	Current THD for 13-level Cascaded H-bridge Multilevel Inverter	89
4.7(a)	Voltage THD for 15-level Cascaded H-bridge Multilevel Inverter	96
4.7(b)	Current THD for 15-level Cascaded H-bridge Multilevel Inverter	96

© This item is protected by original copyright

## LIST OF FIGURES

No.		Page
1.1	Cascaded H-bridge Multilevel Inverter	2
2.1	5-level Diode-Clamped Multilevel Inverter	7
2.2	5-level Flying-Capacitor Multilevel Inverter	12
2.3	5-level Cascaded H-bridge Multilevel Inverter	16
2.4(a)	Required Number of Diode for Multilevel Inverter	20
2.4(b)	Required Number of Capacitor for Multilevel Inverter	21
2.4(c)	Required Number of Total Components for Multilevel Inverter	21
3.1	5-level Cascaded H-bridge Multilevel Inverter	23
3.2	Swapped Zero-level Switching Pattern	24
3.3	Flow Chart of Project	33
3.4	Output Voltage Waveform for Multilevel Inverter	35
4.1	Simulation Parameters	47
	Simulation Results of 3-level Cascaded H-bridge Multilevel Inverter	
4.2(a)	Voltage Output Waveform with Switching Strategy A	48
4.2(b)	Voltage Output Waveform with Switching Strategy B	48
4.2(c)	Voltage Output Waveform with Switching Strategy C	48
4.2(d)	Voltage Output Waveform with Switching Strategy D	48
4.3(a)	Current Output Waveform with Switching Strategy A and PF=1.0	49
4.3(b)	Current Output Waveform with Switching Strategy B and PF=1.0	49
4.3(c)	Current Output Waveform with Switching Strategy C and PF=1.0	49
4.3(d)	Current Output Waveform with Switching Strategy D and PF=1.0	49

4.4(a)	Current Output Waveform with Switching Strategy A and PF=0.75	50
4.4(b)	Current Output Waveform with Switching Strategy B and PF=0.75	50
4.4(c)	Current Output Waveform with Switching Strategy C and PF=0.75	50
4.4(d)	Current Output Waveform with Switching Strategy D and PF=0.75	50
4.5(a)	Current Output Waveform with Switching Strategy A and PF=0.50	51
4.5(b)	Current Output Waveform with Switching Strategy B and PF=0.50	51
4.5(c)	Current Output Waveform with Switching Strategy C and PF=0.50	51
4.5(d)	Current Output Waveform with Switching Strategy D and PF=0.50	51
4.6	Voltage FFT Spectrum of 3-Level CHB MLI	52
4.7	Current FFT Spectrum of 3-level CHB MLI with PF=1.0	52
4.8	Current FFT Spectrum of 3-level CHB MLI with PF=0.75	53
4.9	Current FFT Spectrum of 3-level CHB MLI with PF=0.50	53
Simulation Results of 5-level Cascaded H-bridge Multilevel Inverter		
4.10(a)	Voltage Output Waveform with Switching Strategy A	55
4.10(b)	Voltage Output Waveform with Switching Strategy B	55
4.10(c)	Voltage Output Waveform with Switching Strategy C	55
4.10(d)	Voltage Output Waveform with Switching Strategy D	55
4.11(a)	Current Output Waveform with Switching Strategy A and PF=1.0	56
4.11(b)	Current Output Waveform with Switching Strategy B and PF=1.0	56
4.11(c)	Current Output Waveform with Switching Strategy C and PF=1.0	56
4.11(d)	Current Output Waveform with Switching Strategy D and PF=1.0	56
4.12(a)	Current Output Waveform with Switching Strategy A and PF=0.75	57
4.12(b)	Current Output Waveform with Switching Strategy B and PF=0.75	57
4.12(c)	Current Output Waveform with Switching Strategy C and PF=0.75	57
4.12(d)	Current Output Waveform with Switching Strategy D and PF=0.75	57

4.13(a)	Current Output Waveform with Switching Strategy A and PF=0.50	58
4.13(b)	Current Output Waveform with Switching Strategy B and PF=0.50	58
4.13(c)	Current Output Waveform with Switching Strategy C and PF=0.50	58
4.13(d)	Current Output Waveform with Switching Strategy D and PF=0.50	58
4.14	Voltage FFT Spectrum for 5-level CHB MLI	59
4.15	Current FFT Spectrum for 5-Level CHB MLI with PF=1.0	59
4.16	Current FFT Spectrum for 5-Level CHB MLI with PF=0.75	60
4.17	Current FFT Spectrum for 5-Level CHB MLI with PF=0.50	60
Simulation Results of 7-level Cascaded H-bridge Multilevel Inverter		
4.18(a)	Voltage Output Waveform with Switching Strategy A	62
4.18(b)	Voltage Output Waveform with Switching Strategy B	62
4.18(c)	Voltage Output Waveform with Switching Strategy C	62
4.18(d)	Voltage Output Waveform with Switching Strategy D	62
4.19(a)	Current Output Waveform with Switching Strategy A and PF=1.0	63
4.19(b)	Current Output Waveform with Switching Strategy B and PF=1.0	63
4.19(c)	Current Output Waveform with Switching Strategy C and PF=1.0	63
4.19(d)	Current Output Waveform with Switching Strategy D and PF=1.0	63
4.20(a)	Current Output Waveform with Switching Strategy A and PF=0.75	64
4.20(b)	Current Output Waveform with Switching Strategy B and PF=0.75	64
4.20(c)	Current Output Waveform with Switching Strategy C and PF=0.75	64
4.20(d)	Current Output Waveform with Switching Strategy D and PF=0.75	64
4.21(a)	Current Output Waveform with Switching Strategy A and PF=0.50	65
4.21(b)	Current Output Waveform with Switching Strategy B and PF=0.50	65
4.21(c)	Current Output Waveform with Switching Strategy C and PF=0.50	65
4.21(d)	Current Output Waveform with Switching Strategy D and PF=0.50	65

4.22	Voltage FFT Spectrum of 7-Level CHB MLI	66
4.23	Current FFT Spectrum of 7-Level CHB MLI with PF=1.0	66
4.24	Current FFT Spectrum of 7-Level CHB MLI with PF=0.75	67
4.25	Current FFT Spectrum of 7-Level CHB MLI with PF=0.50	67
	Simulation Results of 9-level Cascaded H-bridge Multilevel Inverter	
4.26(a)	Voltage Output Waveform with Switching Strategy A	69
4.26(b)	Voltage Output Waveform with Switching Strategy B	69
4.26(c)	Voltage Output Waveform with Switching Strategy C	69
4.26(d)	Voltage Output Waveform with Switching Strategy D	69
4.27(a)	Current Output Waveform with Switching Strategy A and PF=1.0	70
4.27(b)	Current Output Waveform with Switching Strategy B and PF=1.0	70
4.27(c)	Current Output Waveform with Switching Strategy C and PF=1.0	70
4.27(d)	Current Output Waveform with Switching Strategy D and PF=1.0	70
4.28(a)	Current Output Waveform with Switching Strategy A and PF=0.75	71
4.28(b)	Current Output Waveform with Switching Strategy B and PF=0.75	71
4.28(c)	Current Output Waveform with Switching Strategy C and PF=0.75	71
4.28(d)	Current Output Waveform with Switching Strategy D and PF=0.75	71
4.29(a)	Current Output Waveform with Switching Strategy A and PF=0.50	72
4.29(b)	Current Output Waveform with Switching Strategy B and PF=0.50	72
4.29(c)	Current Output Waveform with Switching Strategy C and PF=0.50	72
4.29(d)	Current Output Waveform with Switching Strategy D and PF=0.50	72
4.30	Voltage FFT Spectrum of 9-level CHB MLI	73
4.31	Current FFT Spectrum of 9-level CHB MLI with PF=1.0	73
4.32	Current FFT Spectrum of 9-level CHB MLI with PF=0.75	74
4.33	Current FFT Spectrum of 9-level CHB MLI with PF=0.50	74

### Simulation Results of 11-level Cascaded H-bridge Multilevel Inverter

4.34(a)	Voltage Output Waveform with Switching Strategy A	76
4.34(b)	Voltage Output Waveform with Switching Strategy B	76
4.34(c)	Voltage Output Waveform with Switching Strategy C	76
4.34(d)	Voltage Output Waveform with Switching Strategy D	76
4.35(a)	Current Output Waveform with Switching Strategy A and PF=1.0	77
4.35(b)	Current Output Waveform with Switching Strategy B and PF=1.0	77
4.35(c)	Current Output Waveform with Switching Strategy C and PF=1.0	77
4.35(d)	Current Output Waveform with Switching Strategy D and PF=1.0	77
4.36(a)	Current Output Waveform with Switching Strategy A and PF=0.75	78
4.36(b)	Current Output Waveform with Switching Strategy B and PF=0.75	78
4.36(c)	Current Output Waveform with Switching Strategy C and PF=0.75	78
4.36(d)	Current Output Waveform with Switching Strategy D and PF=0.75	78
4.37(a)	Current Output Waveform with Switching Strategy A and PF=0.50	79
4.37(b)	Current Output Waveform with Switching Strategy B and PF=0.50	79
4.37(c)	Current Output Waveform with Switching Strategy C and PF=0.50	79
4.37(d)	Current Output Waveform with Switching Strategy D and PF=0.50	79
4.38	Voltage FFT Spectrum of 11-Level CHB MLI	80
4.39	Current FFT Spectrum of 11-Level CHB MLI with PF=1.0	80
4.40	Current FFT Spectrum of 11-Level CHB MLI with PF=0.75	81
4.41	Current FFT Spectrum of 11-Level CHB MLI with PF=0.50	81

### Simulation Results of 13-level Cascaded H-bridge Multilevel Inverter

4.42(a)	Voltage Output Waveform with Switching Strategy A	83
4.42(b)	Voltage Output Waveform with Switching Strategy B	83
4.42(c)	Voltage Output Waveform with Switching Strategy C	83

4.42(d)	Voltage Output Waveform with Switching Strategy D	83
4.43(a)	Current Output Waveform with Switching Strategy A and PF=1.0	84
4.43(b)	Current Output Waveform with Switching Strategy B and PF=1.0	84
4.43(c)	Current Output Waveform with Switching Strategy C and PF=1.0	84
4.43(d)	Current Output Waveform with Switching Strategy D and PF=1.0	84
4.44(a)	Current Output Waveform with Switching Strategy A and PF=0.75	85
4.44(b)	Current Output Waveform with Switching Strategy B and PF=0.75	85
4.44(c)	Current Output Waveform with Switching Strategy C and PF=0.75	85
4.44(d)	Current Output Waveform with Switching Strategy D and PF=0.75	85
4.45(a)	Current Output Waveform with Switching Strategy A and PF=0.50	86
4.45(b)	Current Output Waveform with Switching Strategy B and PF=0.50	86
4.45(c)	Current Output Waveform with Switching Strategy C and PF=0.50	86
4.45(d)	Current Output Waveform with Switching Strategy D and PF=0.50	86
4.46	Voltage FFT Spectrum of 13-Level CHB Multilevel Inverter	87
4.47	Current FFT Spectrum of 13-Level CHB MLI with PF=1.0	87
4.48	Current FFT Spectrum of 13-Level CHB MLI with PF=0.75	88
4.49	Current FFT Spectrum of 13-Level CHB MLI with PF=0.50	88
© Simulation Results of 15-level Cascaded H-bridge Multilevel Inverter		
4.50(a)	Voltage Output Waveform with Switching Strategy A	90
4.50(b)	Voltage Output Waveform with Switching Strategy B	90
4.50(c)	Voltage Output Waveform with Switching Strategy C	90
4.50(d)	Voltage Output Waveform with Switching Strategy D	90
4.51(a)	Current Output Waveform with Switching Strategy A and PF=1.0	91
4.51(b)	Current Output Waveform with Switching Strategy B and PF=1.0	91
4.51(c)	Current Output Waveform with Switching Strategy C and PF=1.0	91

4.51(d)	Current Output Waveform with Switching Strategy D and PF=1.0	91
4.52(a)	Current Output Waveform with Switching Strategy A and PF=0.75	92
4.52(b)	Current Output Waveform with Switching Strategy B and PF=0.75	92
4.52(c)	Current Output Waveform with Switching Strategy C and PF=0.75	92
4.52(d)	Current Output Waveform with Switching Strategy D and PF=0.75	92
4.53(a)	Current Output Waveform with Switching Strategy A and PF=0.50	93
4.53(b)	Current Output Waveform with Switching Strategy B and PF=0.50	93
4.53(c)	Current Output Waveform with Switching Strategy C and PF=0.50	93
4.53(d)	Current Output Waveform with Switching Strategy D and PF=0.50	93
4.54	Voltage FFT Spectrum of 15-Level CHB MLI	94
4.55	Current FFT Spectrum of 15-Level CHB MLI with PF=1.0	94
4.56	Current FFT Spectrum of 15-Level CHB MLI with PF=0.75	95
4.57	Current FFT Spectrum of 15-Level CHB MLI with PF=0.50	95
4.58	THD against Level of Cascaded H-bridge Multilevel Inverter	97
4.59	Fundamental Voltage of the 3- to 15-Level CHB Inverters	98
4.60	Current THD with Switching Strategy A	100
4.61	Current THD with Switching Strategy B	100
4.62	Current THD with Switching Strategy C	100
4.63	Current THD with Switching Strategy D	100

## LIST OF ABBREVIATIONS

AC	Alternating Current
DC	Direct Current
THD	Total Harmonic Distortion
MOSFET	Metal Oxide Semiconductor Field Effect Transistor
NPC	Neutral Point Clamped
MLI	Multilevel Inverter
CHB	Cascaded H-bridge
PV	Photovoltaic
VS	Verse

© This item is protected by original copyright

## **Kajian Perbandingan Strategi Pensuisan Bagi Lata Tetimbang-H Penyongsang Berbilang Aras.**

### **ABSTRAK**

Penyongsang berbilang aras mampu menjana gelombang keluaran bertangga AC tanpa memerlukan penapis pasif yang besar. Oleh itu, dikalangan beberapa jenis penyongsang, penyongsang berbilang aras menjadi semakin popular bagi kegunaan fotovolta. Jika sudut pensuisan setiap aras voltan tidak dipilih dengan baik, jumlah herotan harmonic (THD) bagi gelombang keluaran voltan tersebut mungkin tidak boleh diterima. Di dalam projek ini, empat teknik susunan sudut pensuisan telah digunakan ke atas penyongsang lata tetimbang-H berbilang aras. Prestasi untuk 3-, 5-, 7-, 9-, 11-, 13-, dan 15-aras penyongsang lata tetimbang-H berbilang aras dengan empat teknik susunan sudut pensuisan pada beban factor kuasa yang berbeza telah dinilai dan diperbandingkan dengan menggunakan perisian PSIM. Tujuan keputusan simulasi penyongsang lata tetimbang-H berbilang aras ini dinilai dan dibandingkan dengan beban factor kuasa yang berbeza adalah untuk menganalisis kesan ke atas beban kearuhan terhadap THD voltan dan arus. Keputusan simulasi menunjukkan terdapat satu teknik yang mampu menjana gelombang voltan dan arus keluaran dengan nilai THD yang rendah manakala beban factor kuasa juga mampu menghasilkan gelombang keluaran arus yang THD rendah. Sebagai tambahan, satu daripada teknik bagi menghasilkan gelombang keluaran voltan tersebut dihasilkan dengan menggunakan voltan asas yang tinggi.

## **Comparative Study of Switching Strategies for Cascaded H-Bridge Multilevel Inverter.**

### **ABSTRACT**

Multilevel inverters are capable of producing AC staircase output waveform without bulky passive filter. Therefore, among different types of inverters the multilevel inverters are gaining popularity for photovoltaic applications. If the switching angle of every voltage level is not carefully chosen then the total harmonic distortion (THD) of voltage output waveform may become unacceptable. In this project, four switching angle arrangement techniques are applied to a cascaded H-bridge multilevel inverter. The performance of 3-, 5-, 7-, 9-, 11-, 13- and 15-level cascaded H-bridge multilevel inverter with four switching angle arrangement techniques at different power factor loads have been evaluated and compared by using PSIM software. The purpose of evaluating and comparing the simulation results of cascaded H-bridge multilevel inverter with different power factor loads is to analyze the effects of inductive load on the THD of voltage and current. Simulation results show that one of technique is able to generate an output voltage and current waveform with lowest THD whilst one of the power factor loads is also able to produce the output current waveform with lowest THD. In addition, one of the techniques produces output voltage waveform with the highest fundamental voltage component.

© This item is protected by copyright law

# CHAPTER 1

## INTRODUCTION

### 1.1 Background

Nowadays, many renewable resources have been explored for different applications. Among them, solar photovoltaic (PV) is gaining popularity for electric energy generation. Solar PV system offer better performance compared to other renewable resources due to the vast availability of solar radiations (Trabelsi & Ben-Brahim, 2011). The electric energy generated from solar PV system is in DC form and it needs to be converted to AC voltage output waveform (Daher et al., 2008). Different types of inverter have been proposed by the researchers. The staircase AC voltage output waveform of multilevel inverter consists of low total harmonic distortion (THD) and hence does not require expensive filters. Therefore, multilevel inverters gain high popularity and applications among different types of inverter (Adam et al., 2012; Cecati et al., 2010).

The concept of multilevel inverters has been introduced since 1975. In 1975, the first multilevel inverter was proposed (Baker & Bannister, 1975). Separate DC-sourced H-bridge cells are placed in series to synthesize a staircase AC output voltage. The term multilevel began with the three-level converter (Nabae et al., 1981). The basic multilevel inverters can be divided into three types such as diode-clamped multilevel inverter, flying-capacitor multilevel inverter and cascaded H-bridge multilevel inverter. The diode-clamped multilevel inverter was proposed in 1981. It is also called the Neutral-

Point Clamped (NPC) inverter (Choi et al., 1991). This topology consists of large number of clamping-diode and it uses capacitors in series to divide the DC bus voltage into a set of voltage levels. The discharging rate for each capacitor is different and it has higher THD. The flying-capacitor (capacitor-clamped) multilevel inverter was introduced in 1992 (Meynard & Foch, 1992). The flying capacitors multilevel inverter requires large number of storage capacitors and the balancing of storage capacitor makes the inverter control complicated. In addition, this inverter has switching redundancy and due to several switching redundancy, the switch utilization of flying-capacitor multilevel inverter are poor (Rashid, 2003).

Recently cascaded H-bridge multilevel inverter is gaining popularity among the inverter topologies for stand-alone PV systems (Najafi et al., 2010). Figure 1.1 shows the schematic diagram of a cascaded H-bridge multilevel inverter.

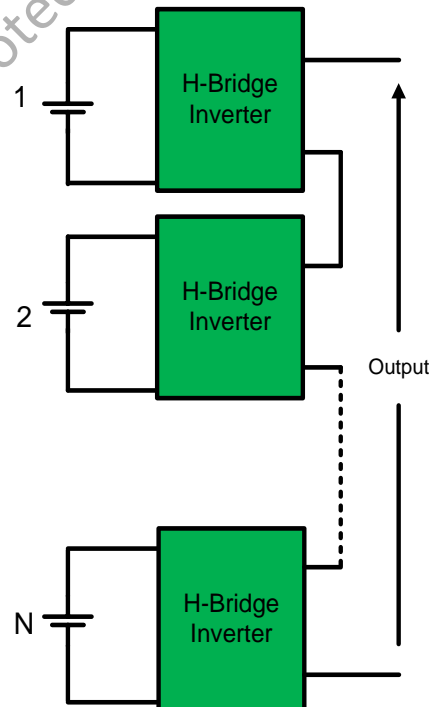

Figure 1.1: Cascaded H-Bridge Multilevel Inverter

The optimized circuit layout and packing of cascaded H-bridge multilevel inverter is possible because each level has the same structure and there is no extra clamping diode and voltage-balancing capacitor. The number of output voltage levels can be easily adjusted by adding or removing the H-bridge. The more benefits of cascaded H-bridge multilevel inverters compared to diode-clamped and flying-capacitor multilevel inverter are discussed in literature review. Therefore this project focused on cascaded H-bridge multilevel inverter. The operation and control of the cascaded H-bridge multilevel inverter topology is discussed in detail in methodology section.

## **1.2 Problem Statement**

The development of renewable energy such as solar, wind and geothermal etc. has been increased due to the concerns of global warming and continuing rise of oil prices. The solar energy is among the most important source of renewable energy available today. Photovoltaic system converts solar radiation to electricity through photovoltaic panels. The power generated by photovoltaic panel is in DC form. Therefore it needs to be converted into AC form using a power inverter. Several inverter topologies have been proposed in the past and each inverter topology has different characteristics. The conventional inverter requires a bulky filter to produce sinusoidal AC output voltage waveform. Recently, multilevel inverters gain popularity in PV system. Unlike the conventional inverter, the multilevel inverter does not required bulky filter to generate near sinusoidal AC output waveform. However, if the proper switching angle arrangement technique is not applied then the resulted THD of multilevel inverter may become unacceptable.

### **1.3 Objectives**

The objectives of this project are as follows:

- i. To model the cascaded H-bridge multilevel inverter.
- ii. To compare the voltage and current total harmonics distortion (THD) of cascaded H-bridge multilevel inverter with different switching angle arrangement techniques.
- iii. To evaluate the performance of cascaded H-bridge multilevel inverter with resistive and inductive load.

### **1.4 Scope of Project**

This project investigates the performance of 3-, 5-, 7-, 9-, 11-, 13- and 15-level cascaded H-bridge multilevel inverters with four different switching angle arrangement techniques and is modeled in PSIM software. The voltage and current total harmonic distortions of cascaded H-bridge multilevel inverter with four switching strategies are compared. In addition, the performance of cascaded H-bridge multilevel inverter with different power factor loads is investigated. From the simulation results, the total harmonic distortion of cascaded H-bridge multilevel inverters with different power factor loads was compared to analyze the effects of pure resistive and inductive load toward THD results. Lastly, from the different switching angle arrangement techniques and different power factor loads that are applied, the cause that contributes to the different results of THD valued will be discussed.

## 1.5 Dissertation Synopsis

This dissertation is organized into five main chapters. The outlines of the following chapters are summarized as below:-

Chapter two presents the literature review of the research. The literature review consists of operation, advantages, disadvantages and applications of diode-clamped, flying- capacitor and cascaded H-bridge multilevel inverter, comparison between diode-clamped, flying-capacitor and cascaded H-bridge multilevel inverter and motivation.

Chapter three discusses the methodologies used in this project. This chapter presents the operation of 5-level cascaded H-bridge multilevel inverter, flow chart of project activities, power factor calculation and the description of 3-, 5-, 7-, 9-, 11-, 13- and 15- level cascaded H-bridge multilevel inverter.

Chapter four analyzes simulation results of 3-, 5-, 7-, 9-, 11-, 13- and 15- level cascaded H-bridge multilevel inverter and also it presents the results and discussion.

Chapter five draws the conclusion according to the objectives of project and provides the recommendation for future work.

## CHAPTER 2

### LITERATURE REVIEW

#### 2.1 Introduction

Nowadays, multilevel inverters are widely used in medium-voltage applications. The multilevel inverter starts from three level inverters. The multilevel inverters have several benefits. One of the significant advantages of multilevel inverter configuration is the harmonic reduction in the output waveform without increasing switching frequency or decreasing the inverter power output and due to harmonic reduction, the quantity of output filters can be decreased (Pharne et al., 2013). Therefore the reduction in cost will benefit the extension of multilevel inverter application.

The multilevel inverter can be classified into three basic types such as diode-clamped, flying-capacitor and cascaded H-bridge multilevel inverter. The operation, advantages, disadvantages and applications of diode-clamped, flying-capacitor and cascaded H-bridge multilevel inverter are discussed in Section 2.2, 2.3 and 2.4, respectively. The comparison between diode-clamped, flying-capacitor and cascaded H-bridge multilevel inverter are presented in Section 2.5.

## 2.2 Diode-Clamped Multilevel Inverter (DCMLI)

In 1981 Nabae et al. introduced the diode-clamped multilevel inverter. First proposed diode-clamped inverter essentially consists of three levels (Nabae et al., 1981). In the 1990s, researchers published many articles on the experimental results of four, five, and six-level diode-clamped converter for several uses such as, variable speed motor drive and high voltage system interconnections (Jih-Sheng et al., 1995). Figure 2.1 shows the circuit diagram of a 5-level diode clamped multilevel inverter. It consists of eight power MOSFETs, twelve clamping-diodes, one DC voltage source and four capacitors.

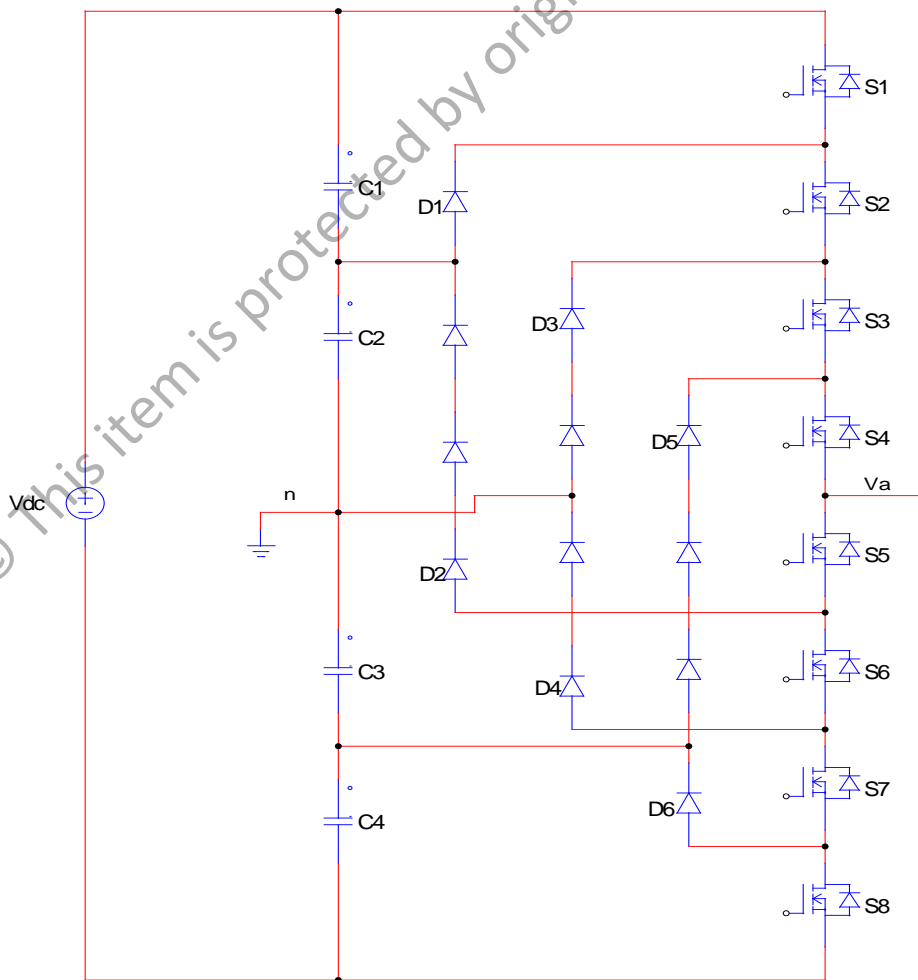

Figure 2.1: 5-level Diode-clamped Multilevel Inverter (Nabae et al., 1981)