

PAPER • OPEN ACCESS

## An Overview on Overvoltage Phenomena in Power Systems

To cite this article: N S Othman *et al* 2019 *IOP Conf. Ser.: Mater. Sci. Eng.* **557** 012013

View the [article online](#) for updates and enhancements.

You may also like

- [Third quadrant overvoltage ruggedness of p-gate GaN HEMTs](#)  
Lifeng Yuan, Feng Zhou, Yulei Jin et al.
- [Electrochemical Performance of a Spatially Distributed ECPProx Reactor](#)  
Ivonne Karina Peña Arias, Richard Hanke-Rauschenbach and Kai Sundmacher
- [Effect of Electrochemical Conditions on Material Removal Rate in Electrochemical Oxidation Assisted Machining](#)  
Eunseok Nam, Chan-Young Lee, Jaehong Min et al.

**PRIME**  
PACIFIC RIM MEETING  
ON ELECTROCHEMICAL  
AND SOLID STATE SCIENCE

**HONOLULU, HI**  
October 6-11, 2024

*Joint International Meeting of*  
The Electrochemical Society of Japan  
(ECS)  
The Korean Electrochemical Society  
(KECS)  
The Electrochemical Society (ECS)

Early Registration Deadline:  
**September 3, 2024**

**MAKE YOUR PLANS  
NOW!**

# An Overview on Overvoltage Phenomena in Power Systems

N S Othman<sup>1</sup>, M N K H Rohani<sup>1</sup>, W A Mustafa<sup>2</sup>, C L Wooi<sup>1</sup>, A S Rosmi<sup>1</sup>, N F M Shakur<sup>1</sup>, R Juliangga<sup>1</sup>, Wan Khairunizam<sup>3</sup>, I Zunaidi<sup>4</sup>, Z M Razlan<sup>3</sup> and Shahrman A B<sup>3</sup>

<sup>1</sup>Centre of Excellence for Renewable Energy (CERE), School of Electrical System Engineering, Pauh Putra Main Campus, Universiti Malaysia Perlis, 02600 Arau, Perlis, Malaysia.

<sup>2</sup>Department of Electrical Technology Engineering, Faculty of Engineering Technology, Universiti Malaysia Perlis (UniMAP), UniCITI Alam Campus, Sungai Chuchuh, 02100 Padang Besar, Perlis Malaysia.

<sup>3</sup>School of Mechatronics Engineering, Universiti Malaysia Perlis, 02600 Arau, Malaysia

<sup>4</sup>Faculty of Technology, University of Sunderland, St Peter's Campus, Sunderland, SR6 0DD, United Kingdom

*E-mail: syakinaothman@gmail.com*

**Abstract.** Overvoltage happens in a condition where the voltage is increased and exceed its design limit. This situation may lead to harmful damage to machines or related equipment that connected to the system. Overvoltage can exist in a form of transient, voltage spike or permanent, depending on its duration. Types of overvoltage consist of lightning overvoltage and switching overvoltage. Overvoltage that caused by lightning is considerate as natural phenomena, while switching overvoltage exists from the system itself, either by the interruption of faults or inappropriate connection of circuit breaker contacts. This paper is discussed about overvoltage phenomenon including causes and effects of overvoltage and overvoltage protection towards power system.

## 1. Introduction

Overvoltage in power system is defined as the increase in voltage for the very short time in the power system. It is also known as the voltage transients or voltage surge [1-3]. The overvoltage in the power system can be classified into two factors which are an internal factor (temporary, switching) or external factor (usually lightning) [4-6]. Overvoltage in power systems can happen for several reasons such as lightning, faults, and disconnection with the most destructive is caused by a lightning strike to the power system [7-8].

A single lightning strike can carry up to 300 kV voltages and almost 30 kA of current which is very high and can cause device and insulation breakdown [9]. Therefore, it is vital to design the power system so that the expected overvoltage will be lower than the value that can be withstood by the system [10]. But such a system will be costly and is not practical in real life application. The best way is to design the power system so that the damage from the overvoltage can be minimized.

The protection against overvoltage is very important to ensure smooth operation of the power system and to protect the insulation of power equipment (air, oil, SF6) which is very sensitive of the high voltage [11].

## 2. Types and Causes of Overvoltage

Overvoltage phenomena in the power system can be classified into two types which are the internal overvoltage and external overvoltage. Internal overvoltage is caused by the changes in the operating conditions of the power system. There are three common types of internal overvoltage in the power system.



### 2.1 Temporary over voltage (Sustained over voltage)

According to IEEE Standard 100-2000, the temporary overvoltage is defined as an oscillatory phase-to-ground or phase-to-phase overvoltage that is at a given location of relatively long duration (seconds, even minutes) and that is undamped or only weakly damped [12]. This type of transient is typically caused by faults (earth fault, single-phase faults etc), switching operations (or sudden disconnection) or from nonlinearities (Ferro resonance effects, harmonics). Temporary overvoltage can be differentiating from other types by the amplitude, duration, the frequencies of oscillation or the fall time ([C/PE4] 1313.1-1996, C57.12.80-1978r) [13].

The magnitude of temporary overvoltage is characteristically low compared to other types of overvoltage. The magnitude usually just a few percents to 50 percent above the nominal operating voltage except for several cases such as ferro resonance which can reach up to 300-400 percent above the nominal operating voltage [14-15]. The most common occurrence of temporary overvoltage is happening between healthy phase and the earth. When a fault happens, it will cause a voltage drop at the faulted phase and may result in overvoltage at the unfaulted phases.

### 2.2 Slow-front over voltage (Switching overvoltage)

Switching overvoltage, as the name itself suggest is caused by the switching operation in the power system or sometimes can be because of fault [16-17]. This type of overvoltage is quite common since switching operations are carried out routinely in the power system as part of the testing process. Due to the Ferranti Effect, when an unloaded long line is charged, the voltage at the receiving end will increase in a significantly high amount that causes overvoltage to the system [18]. The same case happens in transformer operation where the transient can occur when the primary side of the transformer is switched on. The frequency content of switching transients depends on system parameters as illustrates in probability distribution curves of measured line switching overvoltage as shown in Figure 1 [19].

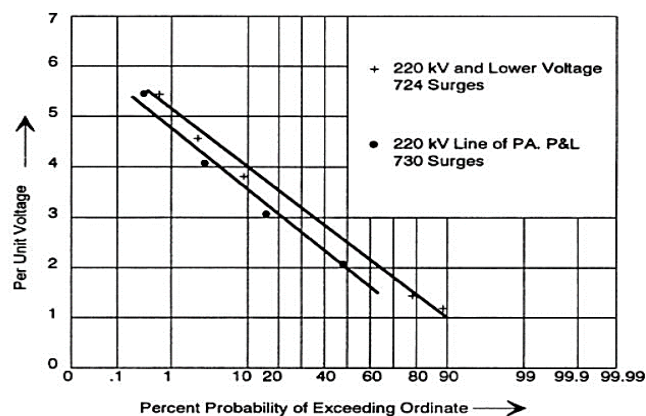

**Figure 1.** Probability distribution curves of measured line switching overvoltage [19].

### 2.3 Very-fast overvoltage

Very-fast overvoltage is happening due to the arc interruption and restriking when opening disconnecter. It can be caused by switching operation, a fault in gas-insulated substation (GIS) and certain lighting condition. In GIS, the substation operation itself can cause overvoltage because of the fast breakdown of the gas gap and the unrestrained propagation of the surge in addition to the high oscillation frequency (50 kHz-100 MHz) that result from the very short distance between two adjacent transition point in GIS [20-21]. However, the transient surges are only dangerous to equipment located close to the disconnecter (heats wiring, causes internal resonance).

External overvoltages originates from atmospheric phenomena, primarily due to lightning [22-23]. It can be because of direct lightning stroke, electromagnetically induced overvoltages due to lightning discharge taking place near the line (side stroke), back flashover and electrostatically induced voltages.

This type of overvoltage is also known as lightning overvoltage or fast-front overvoltage. A lightning can stroke generally anywhere on a power system or nearby object even if it tends to strike the tallest structure. Unlike other types of overvoltage, which is proportional to the system voltage, lightning overvoltages are dependent on system impedances instead of system voltage. It is almost impossible economically and practically to protect distribution or lower-kilovolt-level transmission lines to withstand this type of overvoltage.

### 3. Overvoltage Protection

Overvoltage may be of transient or persistent nature. There are two categories, internal and external. This overvoltage can source destruction to insulators and substation gear [24-25]. Thus, it is required to provide facilities to protect insulators and other gear from the damaging of overvoltage [26]. The process of protecting the electrical system from the destruction that may be triggered by overvoltage. The use of devices such as bent sirens close to the transmission line and Zener diodes for electronic circuits.

There are dissimilar methods can be used for overvoltage protection, with its specific characteristics. Performance, cost, difficulty and functioning mode all need to be considered when defining the method to use.

#### 3.1 Surge Arresters

Series of construction SiC resistors and spark gaps, which are positioned in porcelain covering, and are commonly named “spark gap arresters” [27]. Overvoltage has a different voltage value, characteristics that differentiate overvoltage protection devices is their rated surge capacity and the achievable level of protection [28].

- Level 1 lightning arrester: Defends against overvoltage and great currents caused straight or secondary lightning strikes
- Level 2 surge arrester: Defends against overvoltage caused electrical switching processes
- Level 3 surge arrester: Defends electrical loads against overvoltage

#### 3.2 SCR Crowbar

Figure 2 shows the crowbar circuit that seats a short circuit across the output if an overvoltage situation is practiced. Characteristically thyristors for example SCRs are used for as they can switch great currents and continue on pending any charge has isolated. Often the thyristor is related back to a fuse that isolates the regulator from needing any more voltage located upon it [29].

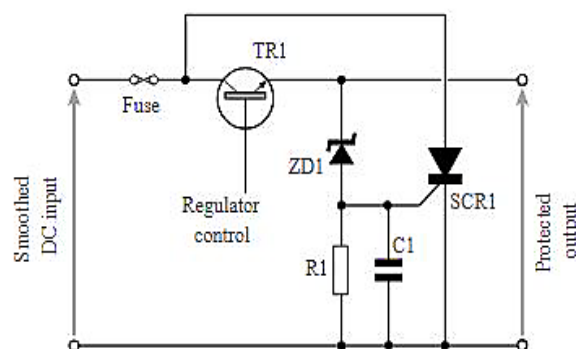

**Figure 2.** Thyristor crowbar circuit [29].

#### 3.3 Voltage Clamping

In the simplest protection system can be on condition that used a Zener diode located across the output as illustrated in Figure 3. With the Zener diode voltage selected to be slightly overhead the determined line voltage, below normal situations it determination not conduct. If the voltage increases too great, then it will start to conduct, clamping the voltage at a worth somewhat overhead the line voltage [30].

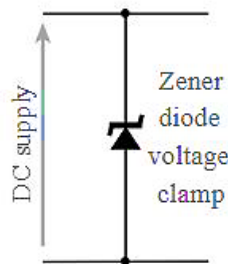

**Figure 3.** Simple Zener diode over-voltage clamp [30].

#### 4. Conclusion

Overvoltage absolutely will cause harm and damage to the insulation of the distribution network equipment. Therefore, it is vital to identify the types and causes of overvoltage so that undesirable damage can be minimized. Various methods of overvoltage protection provide safety towards the performance of power systems networks such as surge arresters, SCR crowbar, and voltage clamping.

#### References

- [1] Sze S M 1969 *Physics of Semiconductor Devices* (New York: Wiley–Interscience)
- [2] Dorman L I 1975 *Variations of Galactic Cosmic Rays* (Moscow: Moscow State University Press) p 103
- [3] Caplar R and Kulisic P 1973 *Proc. Int. Conf. on Nuclear Physics (Munich)* vol 1 (Amsterdam: North-Holland/American Elsevier) p 517
- [4] Szytula A and Leciejewicz J 1989 *Handbook on the Physics and Chemistry of Rare Earths* vol 12, ed K A Gschneidner Jr and L Erwin (Amsterdam: Elsevier) p 133
- [5] Kuhn T 1998 Density matrix theory of coherent ultrafast dynamics *Theory of Transport Properties of Semiconductor Nanostructures (Electronic Materials* vol 4) ed E Schöll (London: Chapman and Hall) chapter 6 pp 173–214
- [6] Xue H and Popov M 2014 Analysis of switching transient overvoltages in the power system of floating production storage and offloading vessel *Electric Power Syst. Res.* **115** 3–10
- [7] A H S, M M and T B 2015 Impact of surge arrester number and placement on reliability and lightning overvoltage level in high voltage substations *Int. J. Electr. Power Energy Syst.* **65** 146–58
- [8] Reza S and Javad G 2017 The effect of grounding system modeling on lightning-related studies of transmission lines *J. Appl. Res. Technol.* **15** 545–54
- [9] Franc B, Filipović-Grčić B and Milardić V 2016 Lightning overvoltage performance of 110 kV air-insulated substation *Electr. Power Syst. Res.* **138** 78–84
- [10] Yu Z, Zhu T, Wang Z, Lu G, Zeng R, Liu Y, Luo J, Wang Y, He J and Zhuang C 2016 Calculation and experiment of induced lightning overvoltage on power distribution line *Electr. Power Syst. Res.* **139** 52–9
- [11] Saad H, Rault P and Denetière S 2018 Study on transient overvoltages in converter station of MMC-HVDC links *Electr. Power Syst. Res.* **160** 397–403
- [12] IEEE 2000 *100-2000 - The Authoritative Dictionary of IEEE Standards Terms*
- [13] Santiago J and Tavares M C 2019 Analysis of half-wavelength transmission line under critical balanced faults: Voltage response and overvoltage mitigation procedure *Electr. Power Syst. Res.* **166** 99–111
- [14] Shariatinasab R, Kermani B and Gholinezhad J 2019 Transient modeling of the wind farms in order to analysis the lightning related overvoltages *Renew. Energy* **132** 1151–66
- [15] Jin E S, Chen X F, Cao D L and Bo Z Q 2012 Theoretical Analysis on High Frequency Ferroresonant Overvoltage *Energy Procedia* **17** 233–40

- [16] Han R, Yang Q, Sima W, Zhang Y, Sun S, Liu T and Chen S 2016 Non-contact measurement of lightning and switching transient overvoltage based on capacitive coupling and pockels effects *Electr. Power Syst. Res.* **139** 93–100
- [17] Filipović-Grčić B, Franc B, Uglešić I, Pavić I, Keitoue S, Murat I and Ivanković I 2017 Monitoring of transient overvoltages on the power transformers and shunt reactors - Field experience in the Croatian power transmission system *Procedia Eng.* **202** 29–42
- [18] Pengcheng Y, Shuiming C and Jinliang H 2010 Effect of Different Arresters on Switching Overvoltages in UHV Transmission Lines *Tsinghua Sci. Technol.* **15** 325–8
- [19] Santoso S and Beaty H W 2017 Power System Overvoltages *Standard Handbook for Electrical Engineers* (McGraw-Hill Education)
- [20] Feng S, Zheng L, Lie J, Sun Y, Chen G and Ji X 2011 Research on arc-grounding overvoltage in the 10kV distribution system *Energy Procedia* **16** 1785–91
- [21] Suo C, Xu X, Zhang W, Gui J, Tan X and Li T 2017 GIS Very Fast Transients Overvoltage Testing Using Electric Field Measurement *Proceedings of the Fifteenth China International Nanoscience and Technology Symposium* pp 23–4
- [22] Trainba M, Christodoulou C A, Vita V and Ekonomou L 2017 Lightning overvoltage and protection of power substations *WSEAS Trans. Power Syst.* **12** 107–14
- [23] Rodrigues R B, Mendes V M F and Catalão J P S 2012 Protection of interconnected wind turbines against lightning effects: Overvoltages and electromagnetic transients study *Renew. Energy* **46** 232–40
- [24] Mokhtari G, Nourbakhsh G, Zare F and Ghosh A 2013 Overvoltage prevention in LV smart grid using customer resources coordination *Energy Build.* **61** 387–95
- [25] Mestas P and Tavares M C 2010 Comparative Analysis of Techniques for Control of Switching Overvoltages During Transmission Lines Energization *Electric Power Syst. Res.* **80** 115–20
- [26] Soloot A H, Høidalen H K and Gustavsen B 2012 The assessment of overvoltage protection within energization of offshore wind farms *Energy Procedia* **24** 151–8
- [27] Napolitano F, Borghetti A, Nucci C A, Martinez M L B, Lopes G P and Dos Santos G J G 2014 Protection against lightning overvoltages in resonant grounded power distribution networks *Electr. Power Syst. Res.* **113** 121–8
- [28] Datsios Z G and Mikropoulos P N 2016 Modeling of lightning impulse behavior of long air gaps and insulators including pre-discharge current: Implications on insulation coordination of overhead transmission lines and substations *Electr. Power Syst. Res.* **139** 37–46
- [29] Patel S S 2015 Over Voltage Protection Using Crowbar Devices for Low Voltage Loads 6703–5
- [30] Wei L, Liu Z and Skibinski G L 2011 DC Bus Voltage Clamp Method to Prevent Over-Voltage Failures in Adjustable Speed Drives *IEEE Trans. Ind. Appl.* **47** 1178–785