



Voice-Based Malay Command Recognition for Smart House Applications

by

**Masyitah binti Abu
(1832322634)**

A dissertation submitted in fulfillment of the requirements for the degree of
Master of Science Embedded System Design Engineering

**School of Computer and Communication Engineering
UNIVERSITI MALAYSIA PERLIS**

2019

ACKNOWLEDGMENT

Assalamualaikum,

First and Foremost, I would like to express my gratitude to the Almighty God, whom with His willing giving me the opportunity to complete the thesis titled Voice-Based Malay Command Recognition for Smart House Applications.

I would like to express my deepest gratitude and appreciation to my supervisor, Dr. Amiza binti Amir and my co-supervisor, Dr. Naimah binti Yaakob for all their support and advice in every way regarding the project. Without them, there is no way I could finish this thesis. Not to mention, my thanks to all students of School of Computer and Communication Engineering Universiti Malaysia Perlis for their kind cooperation. Last but not least, my gazillion thanks to my families and friend who directly and indirectly helped me complete this master thesis.

©This item is protected by original copyright

TABLE OF CONTENTS

| | PAGE |
|---|-------------|
| DECLARATION OF DISSERTATION | i |
| TABLE OF CONTENTS | iii |
| LIST OF TABLES | vii |
| LIST OF FIGURES | viii |
| ABSTRAK | x |
| ABSTRACT | xi |
| CHAPTER 1 INTRODUCTION | 1 |
| 1.1 Background of Voice-Based Malay Command Recognition | 1 |
| 1.2 Problem Statement | 2 |
| 1.3 Project Objectives | 4 |
| 1.4 Scope of Work | 4 |
| 1.5 Thesis Organization | 5 |
| 1.6 Summary | 6 |
| CHAPTER 2 LITERATURE REVIEW | 7 |
| 2.1 Introduction | 7 |
| 2.2 Application of Raspberry Pi | 8 |
| 2.2.1 Hardware Architecture | 8 |
| 2.3 Voice Recognition | 10 |
| 2.3.1 Standard Malay Phonetic | 10 |
| 2.3.2 Classification of Speech | 11 |
| 2.3.3 Speech Characteristic | 12 |

| | | |
|------------------------------|--|-----------|
| 2.4 | Devices | 13 |
| 2.5 | Feature Extraction | 14 |
| 2.5.1 | Pre-processing Techniques | 14 |
| 2.5.1.1 | Endpoint detection | 15 |
| 2.5.1.2 | Pre-emphasis | 15 |
| 2.5.1.3 | Filtering Technique | 16 |
| 2.5.1.4 | Framing and Windowing | 16 |
| 2.5.2 | Mel Frequency Cepstral Coefficients (MFCC) | 17 |
| 2.5.2.1 | Fast Fourier Transform (FFT) | 18 |
| 2.5.2.2 | Mel Filter Bank | 18 |
| 2.5.2.3 | Discrete Cosine Transform (DCT) | 19 |
| 2.5.2.4 | Peak Detection | 19 |
| 2.6 | Voice Recognition Methods | 19 |
| 2.6.1 | Hidden Markov Model (HMM) | 20 |
| 2.6.2 | Artificial Neural Network (ANN) | 20 |
| 2.6.3 | Support Vector Machine (SVM) | 21 |
| 2.6.4 | Audio Fingerprint Method | 22 |
| 2.7 | Performance Criteria | 24 |
| 2.8 | Related Work | 26 |
| 2.9 | Summary | 34 |
| CHAPTER 3 METHODOLOGY | | 35 |
| 3.1 | Introduction | 35 |
| 3.2 | Data Collection | 35 |
| 3.2.1 | Selection of Malay Commands for Smart House Applications | 36 |
| 3.2.2 | Audio Data Collection | 38 |

| | | |
|---|---|-----------|
| 3.3 | Software Design | 40 |
| 3.3.1 | Training Process | 42 |
| 3.3.2 | Classification Process | 43 |
| 3.4 | Robust Quad Based Audio | 44 |
| 3.4.1 | Audio Feature Extraction | 44 |
| 3.4.2 | Scale-Invariant Hashes | 46 |
| 3.4.3 | Storing Hashes | 47 |
| 3.5 | Audio Fingerprint Classification | 48 |
| 3.5.1 | Match Candidate Selection and Filtering | 49 |
| 3.5.2 | Sequence Estimation | 51 |
| 3.5.3 | Match Verification | 51 |
| 3.6 | System Testing | 54 |
| 3.7 | Hardware Design | 55 |
| 3.8 | Summary | 57 |
| CHAPTER 4 RESULT AND DISCUSSION | | 59 |
| 4.1 | Introduction | 59 |
| 4.2 | Experimental Result | 59 |
| 4.2.1 | Noise Resistance | 60 |
| 4.2.2 | Recognition Time | 68 |
| 4.3 | Comparison between Robust Quad-Based Audio Fingerprint and Mel Frequency Cepstral Coefficient (MFCC) - Neural Network | 71 |
| 4.4 | Discussion | 73 |
| CHAPTER 5 CONCLUSION AND FUTURE WORK | | 75 |
| 5.1 | Conclusion | 75 |
| 5.2 | Future Work | 76 |
| REFERENCES | | 77 |

| | |
|-------------------|-----------|
| APPENDIX A | 83 |
| APPENDIX B | 85 |
| APPENDIX C | 87 |

©This item is protected by original copyright

LIST OF TABLES

| NO. | | PAGE |
|------------|---|-------------|
| Table 2.1 | Advantages and Disadvantages of Recognition Method | 23 |
| Table 2.2 | The Accuracy for Feature Extraction | 25 |
| Table 2.3 | Related Work Voice-Based Command Recognition | 31 |
| Table 3.1 | Malay Command for Smart House Applications | 38 |
| Table 4.1 | Comparison between feature extraction of robust quad-based audio fingerprint method and mfcc-neural network | 73 |

©This item is protected by original copyright

LIST OF FIGURES

| NO. | | PAGE |
|-------------|---|------|
| Figure 2.1 | Raspberry Pi Block Diagram | 9 |
| Figure 2.2 | MFCC process for voice-based command recognition | 17 |
| Figure 3.1 | Survey results for commonly used Malay commands to turn on and turn off the television | 37 |
| Figure 3.2 | Survey results for commonly used Malay commands to control the television channel | 37 |
| Figure 3.3 | Example of voice command signals to turn on and off the fan | 39 |
| Figure 3.4 | Example of voice command signal to turn on and off light | 39 |
| Figure 3.5 | Example of voice command signals to turn on and off the television | 39 |
| Figure 3.6 | Example of voice command signals to control television channel | 40 |
| Figure 3.7 | Flowchart of voice-based Malay command recognition for smart house applications | 41 |
| Figure 3.8 | Flowchart for the training process | 42 |
| Figure 3.9 | Flowchart for the classification process | 43 |
| Figure 3.10 | Example of a valid quad. | 45 |
| Figure 3.11 | Flowchart of Voice-based Malay Command for Smart House Application using Raspberry Pi. | 56 |
| Figure 3.12 | Schematic Diagram of Voice-based Malay Command for Smart House Application using Raspberry Pi | 57 |

| | | |
|-------------|--|----|
| Figure 4.1 | Example of the quad for 'Buka Kipas' and 'Tutup Kipas' Command | 61 |
| Figure 4.2 | Example of the quad for 'Buka Lampu' and 'Tutup Lampu' Command | 61 |
| Figure 4.3 | Example of the quad for 'Buka TV' and 'Tutup TV' Command | 61 |
| Figure 4.4 | Example of the quad for 'Siaran Satu', 'Siaran Dua' and 'Siaran Tiga' Command | 62 |
| Figure 4.5 | Diagonal Line Perform Within the quad for 'Buka Kipas' Command | 63 |
| Figure 4.6 | Recognition Rate and precision for each command | 64 |
| Figure 4.7 | Recognition Rate and Precision for input command + SNR for all command | 65 |
| Figure 4.8 | Connection of Raspberry Pi | 66 |
| Figure 4.9 | Output of Raspberry Pi for Fan | 66 |
| Figure 4.10 | Output of Raspberry Pi for Lamp | 67 |
| Figure 4.11 | Output of Raspberry Pi for Television | 68 |
| Figure 4.12 | Training performance for computer and Raspberry Pi | 69 |
| Figure 4.13 | Testing performance for computer and Raspberry Pi | 70 |
| Figure 4.14 | Examples of time taken for the system to recognize one command using computer and Raspberry Pi | 71 |
| Figure 4.15 | Example of feature extraction result for both methods | 73 |

Suara Berasaskan Bahasa Melayu Pengiktirafan Arahan untuk Aplikasi Rumah Pintar

ABSTRAK

Kajian ini berkaitan dengan Pengakuan Perintah Bahasa Melayu Berbasis Suara untuk Aplikasi Rumah Pintar. Pengiktirafan arahan berdasarkan suara biasanya digunakan untuk interaksi manusia-komputer dalam sistem keselamatan, telefon, perkakas rumah dan perkakasan yang direka untuk orang cacat. Kebanyakan kajian penyelidikan semasa pengakuan arahan suara untuk rumah pintar dalam bahasa Inggeris. Kurangnya pembelajaran untuk pengiktirafan arahan suara dalam bahasa Melayu menjadikannya sukar untuk menggunakan perkhidmatan arahan suara untuk rumah pintar di Malaysia. Di samping itu, pengiktirafan ucapan adalah tugas yang tidak remeh dalam pemrosesan bahasa semula jadi. Objektif utama projek ini adalah untuk mengenal pasti arahan yang digunakan untuk alat rumah pintar menggunakan bahasa Melayu dan reka bentuk algoritma untuk sistem ini. Setelah itu, algoritma pengiktirafan suara yang dicadangkan akan digunakan pada Raspberry Pi untuk melihat prestasi perintah Melayu dengan ketepatan dan kesesuaian algoritma yang akan digunakan pada peranti terbenam kos rendah. Dalam projek ini, cahaya, kipas, dan televisyen telah dipilih sebagai peralatan elektrik untuk membina arahan. Perintah ini akan diberikan dalam bahasa Melayu yang standard. Perintah adalah 'Buka Kipas', 'Tutup Kipas', 'Buka Lampu', 'Tutup Lampu', 'Buka TV', 'Tutup TV', 'Siaran 1', 'Siaran 2' dan 'Siaran 3'. Algoritma yang sebelum ini digunakan untuk mengenali lagu, algoritma quad yang kuat, digunakan dalam projek ini untuk pengenalan arahan suara. Sistem pengiktirafan suara yang dicadangkan mempunyai dua proses utama yang dikenali sebagai pengekstrakan ciri dan pengecaman suara. Dalam proses pengekstrakan ciri, cap jari audio akan mengeluarkan data dari quads arahan. Untuk kaedah pengecaman suara, padanan cap jari audio akan digunakan untuk menganalisis arahan audio. Hasil dari projek ini adalah apabila arahan suara yang diberikan oleh pengguna arahan akan mengaktifkan atau menyahaktifkan aplikasi sasaran misalnya apabila pengguna berkata 'cahaya terbuka' lampu harus terbuka. Hasil kedua adalah bunyi latar belakang yang mempengaruhi sistem dikurangi dengan memilih penyaring yang sesuai dan meningkatkan ketepatan sistem. Hasil projek ini telah menunjukkan bahawa algoritma yang dicadangkan sesuai untuk dilaksanakan pada Raspberry Pi dan mencapai tingkat pengiktirafan yang tinggi dengan 87%. Dengan kehadiran bunyi bising dengan 15 dB, algoritma yang dicadangkan mampu mengekalkan kadar pengiktirafan tinggi dengan 82%.

Voice-Based Malay Command Recognition for Smart House Applications

ABSTRACT

This study is related to the voice-based Malay command recognition for smart house applications. Voice-based command recognition is commonly used for human-computer interaction in security systems, phones, household appliances and hardware designed for handicapped people. Most of the current research, study the voice command recognition for smart home in English. Lack of study for voice command recognition in Malay makes it difficult to apply the voice command services for smart home in Malaysia. In addition, speech recognition is a non-trivial task in natural language processing. The main objective of this project is to identify the command used for smart house appliances using Malay and design the algorithm for this system. After that, the proposed voice recognition algorithm will be deployed on a Raspberry Pi to see the performance of Malay command in accuracy and the suitability of the algorithm to be deployed on low cost embedded devices. In this project, light, fan, and television had been chosen as electrical appliances to build the command. The command will be given in standard Malay. The commands are 'Buka Kipas', 'Tutup Kipas', 'Buka Lampu', 'Tutup Lampu', 'Buka TV', 'Tutup TV', 'Siaran 1', 'Siaran 2', and 'Siaran 3'. An algorithm that previously used to recognize songs, the robust quad algorithm, is used in this project for voice command recognition. The proposed voice recognition system has two main processes known as feature extraction and voice recognition. In the feature extraction process, the audio fingerprint will extract data from the command spectral peak. For voice recognition method, audio fingerprint matching will be used to analyze the audio commands. The outcome of this project is when the voice command is given by the user the command will activate or deactivate target application for example when the user said 'open light' the light should be open. The second outcome is the background noise that affects the system is reduced by choosing a suitable filter and increase the accuracy of the system. The results of this project have shown that the proposed algorithm is suitable to be implemented on a Raspberry Pi and achieve a high recognition rate with 87%. In the presence of noise with 15 dB, the proposed algorithm is able to maintain the high recognition rate with 82%.

CHAPTER 1

INTRODUCTION

1.1 Background of Voice-Based Malay Command Recognition

Nowadays human voice is used in many technologies especially in human-computer interface, voice dialling, data entry, ID verification for money transaction, detection of people identity in the crowd, smart house, and control to access the restricted area (Kumar 2015). Besides that, voice-based command recognition is also used in several applications such as for security devices, household appliances, mobile phones, ATMs, and computer (Norhafizah & Othman 2014). This project focusses on voice-based command recognition in controlling electrical appliances in the smart houses.

Ozturk and Unozkan (2010) discussed on how to improve the communication between human and machine, and one of the improvement is by using voice recognition due to many advantages such as voice are neutral, efficient, effective and flexible. In addition, voice can also be set to control the machines and communicating with them. Voice recognition also has been implemented in many applications that can help disabled people to use wheelchairs and home appliances (Ozturk & Unozkan 2010). Although the voice recognition for controlling house appliances has been widely studied, most of the available applications are developed in English. This limits the applicability of these applications for non-English speakers. Hence, the voice recognition system based on other languages is important to ensure the scalability of the application is widely used in different communities.

Recently, research in voice recognition using other different languages such as Japanese and Thai have also attracted attention among research communities (Rahman et al. 2015).

In this thesis, the command used for voice recognition for smart house applications is in Malay. By using Malay language, it can help those critically ill, aged and disabled people in Malaysia who cannot speak English by allowing them to control the appliances without moving. The Malay-based voice recognition is significant to ensure more users from Malaysia are able to use the voice-based control smart home systems. There is research from the Department of Statistic in Malaysia stated that the majority of Malay ethnic in Malaysia is about 67.4% (www.dosm.gov.my 2011). Lately, most of the research and project for voice recognition are based on English speech recognition, and in comparison, other language speech recognition is still limited (Ong & Ahmad 2011).

1.2 Problem Statement

There are many voice-based command recognition systems to control the smart house applications that had been built, but most of the systems were built in English. In Malaysia, there some individuals that cannot communicate well in English. Therefore, when the user used English, their pronunciation may affect the performance of voice-based command recognition. In this case, the user might mispronounce some English word, for example, the word 'light' and 'right.' Hence, the voice-based commands in Malay are needed. However, there are still limited voice-command systems that utilize Malay language (Abd Manan 2006). Abd Manan (2006) proposed a machine learning algorithm by using Support Vector Machine (SVM) as a recognition method to classify the Malay word for the Malay speech recognition of automation systems. Furthermore, more commands will be included in this

project such as television voice control in addition to the available commands that were suggested by Abd Manan (2006).

The second problem of voice-based command recognition is the interference with other noises such as the sound of wind produced by the fan. Based on Norhafizah and Othman (2014) research, voice-based command recognition is susceptible to detect unnecessary noise like screaming, dog barking and crying sound (Norhafizah & Othman 2014). Leechor et al. (2010) stated that voice recognition accuracy and response speed can be affected by environment, they had found that when the commands are given in a noisy environment, low recognition rate will occur, and when the command is given in a quiet environment, a high recognition rate will occur (Leechor et al. 2010). This problem can be solved by using a suitable microphone that can decrease susceptibility due to noise. Besides that, to improve the performance of voice-based command recognition system a noise filter or noise handling algorithm must be developed (Zhe Gong 2014). Hence, a noise filter algorithm is needed to improve the accuracy rate for the proposed Malay voice commands recognition.

Most of the available voice recognition systems for smart houses that implemented on board such as Raspberry Pi and Arduino are designed in English. Oulkar et al. (2017), Gyulyustan and Enkov (2017), and Upadhye and Khan (2017) choose Raspberry Pi to implement their system on board. The authors built their system in English and tested the performance of their systems in Raspberry Pi. Oulkar et al. stated that by using Raspberry Pi and connecting it with a suitable microphone, the accuracy could achieve 99% based on ideal environment (Oulkar et al. 2017; Gyulyustan & Enkov 2017; Upadhye & Khan 2017). Abd Manan (2006) developed his Malay based voice commands in MATLAB and did not

implement it on board. Therefore, the performance of a Malay-based voice command system on a Raspberry Pi is still unknown.

1.3 Project Objectives

The main objective of this study is to develop an on-board voice-based Malay command recognition for smart house applications. Therefore, three objectives must be achieved as follows:

1. To design an algorithm of voice-based Malay command recognition for smart house application by using Robust Quad-Based Audio Fingerprint Method.
2. To incorporate a suitable filtering algorithm to the designed algorithm in objective 1, in order to improve the performance of voice-based Malay command recognition for smart house application.
3. To deploy the algorithm on a Raspberry Pi board and evaluate its performances based on the accuracy and efficiency (recognition time).

1.4 Scope of Work

The scopes of works are as follows:-

1. For smart house application, it only focuses on the command given for fan, light, and television.

2. The command will be recorded in a normal environment room. Normal environment room is a room that only affected by moderate background noise such as the wind sound produced by the fan and electric sound produced by the light when it activates.
3. The speakers choose to undergo this project are of multiple races; the age is ranging between 20 to 30 years old because during this age there are differences between male and female voice. From this information, only 24 speakers are chosen to record 648 samples.

1.5 Thesis Organization

This thesis contains five chapters. All chapters are discussed as follows:

Chapter 1 elaborates the overview of voice-based Malay command recognition for smart house application and problem statement occur in the voice-based command recognition system. The objective and scope of work of this project are described in this chapter.

Chapter 2 details the literature review of this project. Data were extracted from some journals and papers that give enough data for this project. Comparison between journal and paper also done to justify the research gap. This chapter review on what application used for the system, the available method used, and how to achieve the objective of voice-based Malay command recognition for smart house application.

Chapter 3 discusses the methodology that covers voice-based Malay command recognition system definition and flowchart how the system is working. How the command undergoes feature extraction and classification is explained in this chapter.

Chapter 4 analyses the result of voice-based Malay command recognition with the theoretical expectation on characteristics or behaviour of design as compared to a fixed decision. The operation on how Voice-based Malay command recognition for smart house application to operate are elaborated in this chapter.

Chapter 5 describes conclusion and future work for voice-based command recognition by concluding the overall of this project.

1.6 Summary

In this chapter, the background for Voice-based Malay command recognition for smart house application is explained. Next, the problem statement of the research is described. Then, objectives are addressed. Finally, the scope of work that significance to the study are presented. From the background, problem statement and objective, the outcome form voice-based Malay command recognition for smart house application can be expected. In the next chapter, the literature review of this research is discussed.

CHAPTER 2

LITERATURE REVIEW

2.1 Introduction

Controlling smart house application by using voice is one of the efforts that researchers want to achieve. Nowadays, most of the voice-based command recognition systems are in English. By using the English language, it will become a problem for some people that not influence in English so the number of people uses this technology is not satisfied. The only way that can be used to encourage the user to use the technology is by building the voice-based command recognition system in other languages (Barua et al. 2014).

There are several smart house devices proposed by the other researchers. For example, Norhafizah and Othman (2015) chose fan and light for their command devices. The command they chose is “fan on”, “fan off”, “light on”, and “light off” (Norhafizah & Othman 2014). Samah and Osman (2015), stated that there are several devices suitable for “switch on” and “switch off” command for examples light, fan, air conditioner, television, and radio (Samah & Osman 2015). The command built by the researchers is in English. Therefore, in this project, three devices will be chosen to build Malay commands for smart houses application.

2.2 Application of Raspberry Pi

Nowadays most of the voice recognition technology used a computer, an internet module, GSM for Bluetooth and ZigBee network but by using this platform the cost is high and may cause a problem if there is an internet failure. Therefore, Raspberry Pi can be used for voice recognition platform because the size of Raspberry Pi is the same size as the credit card so it is easy to carry compared to the computer. Besides that, Raspberry Pi is chosen because Raspberry Pi itself can be connected online using cloud or offline with Google speech recognition API. Raspberry Pi is a small computer that using ARM as a processor.

2.2.1 Hardware Architecture

The Raspberry Pi is DDR2-SODIMM-mechanically-compatible System on Modules (SoMs) have the processor, memory, eMMC Flash and supporting power circuitry. Raspberry Pi 3 contains a BCM2837 processor, 1Gbyte LPDDR2 RAM, and 4Gbytes eMMC Flash. Raspberry Pi 3 can address more RAM up to 1Gbyte and the ARM CPU complex is Quad-core Cortex A53 with dedicated 512Kbyte L2 cache in BCM2837. Input and Output interfaces and peripherals stay the same and the two chips are mostly software and hardware compatible. The size of Raspberry Pi 3, it is 31 mm in height (“DATASHEET Raspberry Pi Compute Module (CM1) Raspberry Pi Compute Module 3 (CM3) Raspberry Pi Compute Module 3 Lite (CM3L),” 2016). Figure 2.1 shows the block diagram of the Raspberry Pi.

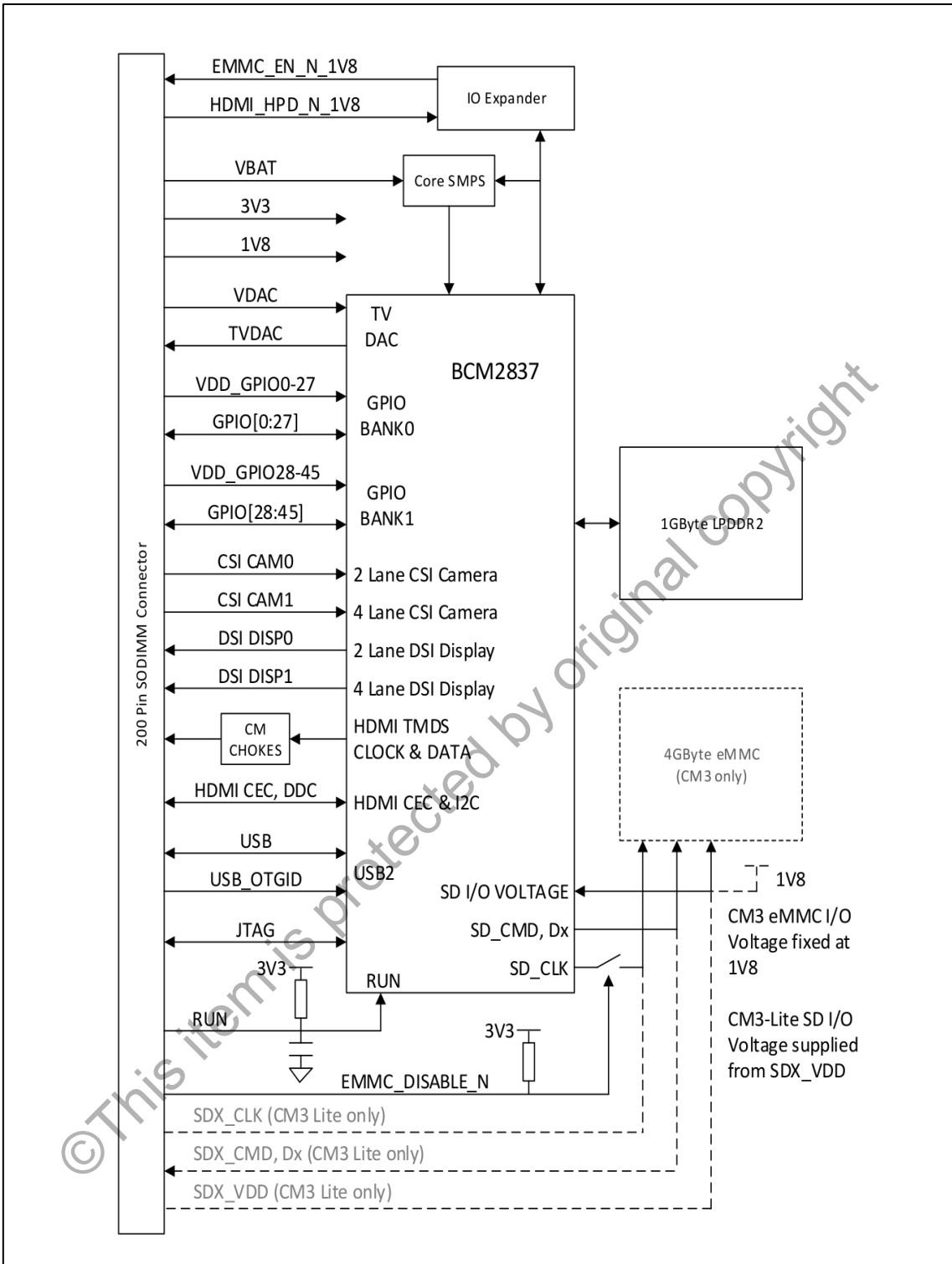

Figure 2.1 Raspberry Pi Block Diagram

2.3 Voice Recognition

Voice recognition is one of the methods used to connect a computer or machine with human, some of the computers also use voice to control its performance for example when the user wants to input word through a keyboard. Instead of typing, it is easier to speak but the process to understand, the speech and voice message given by the user is difficult. Abd Manan (2016) stated that there are many factors that can affect speech and voice command, for examples the gender of the speaker, and the shape of the speaker's mouth. All these factors can give effects towards command given by the speaker. The health of the speaker also may affect the accuracy of voice-based command recognition (Abd Manan 2006).

2.3.1 Standard Malay Phonetic

Standard Malay and English are differences in the way it is written and the sound of its pronunciation. Standard Malay is built from four types of features, which are, primary consonant, secondary consonant, vowels, and diphthongs. Ong and Ahmad (2011) stated that there are nineteen primary consonants that can be classified in Standard Malay. The primary consonants are categories as with and without sound during stops and fricatives, affricates, nasals, lateral, and alveolar. The other three types of Standard Malay features, there are eight secondary consonants, six vowels, and three diphthongs. Besides that, phonemes also are very important for every language because the word is described as a sequence of phonemes. Ong and Ahmad (2011) had been differentiated the phonemes use between English and Standard Malay. The English language has about forty phonemes and Standard Malay only have thirty-six phonemes (Ong & Ahmad 2011).

2.3.2 Classification of Speech

To extract speech recognition many types of classification of speech can be used for speech recognition. Speech recognition has four types of classification: isolated word, connected word, continuous speech and spontaneous speech. Gupta, Pathak, and Saraf (2014) stated that isolated word has sample windows that accept single utterances at a time. For the connected word, it has the same definition as isolated word. The difference is connected word run the separate utterance together by a small amount of pause between each speech. For continuous speech, the speaker can speak the way they always speak while the machine tests the content in the given speech. Utterance boundaries and various difficulties occurred in the continuous speech classification can be determined by using Special methods. The last classification of speech is spontaneous speech, it is a system that has an ability that can handle many kinds of natural speech feature, for example, a list of word that runs together (Gupta, Pathak, & Saraf 2014).

Ankit et al. (2016) and Hemakumar and Punitha (2013) have a different definition from Gupta, Pathak, and Saraf (2014). They stated isolated word speech classifier requires each utterance so both sides of the sample window will be quiet. Another speech classifier stated by Ankit et al. (2016) and Hemakumar and Punitha (2013) is single word. This speech classifier usually not accepted because it needs a single utterance at a time, for example, the speaker only gives a single word and the word will be used for multiple word inputs. Although this classification is very unnatural, it has some advantages. By using this type of classification, it is easier to implement and comparatively simpler because the boundaries between words and the pronunciation of the word given by the user are clear. The disadvantage of this application is it choose different boundaries that will affect the result.

The second classification is connected word it has the similar definition as Gupta, Pathak, and Saraf (2014). The third classification is continuous speech. This classification allows a speaker to speech almost naturally and the computer will determine the content while the speaker is speaking. Without any pause, an adjacent word also can be run together in a word or any other apparent division between words. There are also some disadvantages when continuous speech is used. The vocabulary size grows larger and confusion between words also grow. For spontaneous speech, it is not rehearsed but natural and this type of classification can handle any types of speech that been given naturally by the speaker such as a list of words that been given at the same time and even slight stutter. The disadvantage of this classification is it maybe include the mispronunciations, false-start, and non-word (Ankit et al. 2016; Hemakumar & Punitha 2013).

2.3.3 Speech Characteristic

There are three types of speech analysis used. The first analysis is segmentation analysis, this type of speech technique will be analysed based on the speech frame size, the frame size will be shifted in the range of 10-30 ms to gain the information from the speech given by the speaker. This technique is used to extract vocal tract information of speaker. This analysis is suitable for speaker recognition. Another technique is sub-segmental analysis, this technique also using the frame size for speech analysed but the frame size is shifted in the range of 3-5 ms. The shifting range is different compared to segmentation analysis. The Sub-segmental analysis is used to extract and analyse the characteristic of the excitation state. The last technique is supra-segmental analysis, this technique is used to analysed the characteristics and the behaviour characteristics of the speaker (Gupta et al. 2014; Ankit et al. 2016; Om & Navneet 2013).

2.4 Devices

To record voice command from speaker or user, android application or open-air microphone can be used. NorHafizah and Othman (2014) use an android application to record the users' voice. The advantages of using an Android application the user can control electrical appliances from far distance up to 20 meters (Norhafizah & Othman 2014). Rahman et al (2015) stated that by using Android application to record voice command is more suitable compared to open air voice by using a microphone, but to connect the application with Raspberry Pi Bluetooth module is needed. The authors also stated that by using open air voice there are some problems such as background noises, the mispronunciation of command, and when the distance is far the command will be hard to receive by the system (Rahman et al. 2015). Using android application is better but the cost is expensive.

Kumar (2015) uses a microphone to record the users' voice and the type of microphone the author uses is directional carbon microphone. The author stated that by using this type of microphone the environmental noise is reduced (Kumar 2015) so it is suitable to use in office and house. Oulkar et al. (2017) also use a microphone to record the voice commands, the type of microphone the author used is simple collar type microphone with 3.5mm jack. The accuracy by using this type of microphone is higher (Oulkar et al. 2017). Zhe Gong (2014) had done some experiment to choose the best microphone for his system because the performance of the microphone will affect the voice recognition performance. The authors choose the microphone on the Logitech Webcam because it has the longest voice pick-up distance and clearness (Zhe Gong 2014).