

PAPER • OPEN ACCESS

Design and static structural analysis of a race car chassis for Formula Society of Automotive Engineers (FSAE) event

To cite this article: M L Mohamad *et al* 2017 *J. Phys.: Conf. Ser.* **908** 012042

View the [article online](#) for updates and enhancements.

You may also like

- [Design automation and CAD customization of an EV chassis](#)
Purushottam Nawale, Akshay Kanade, Bhalchandra Nannaware et al.
- [Design and test on high-gap wheeled agricultural chassis for harvesting broccoli](#)
Huimin Xu, Yijin Chen, Miaodan Hu et al.
- [Static Structural Analysis of the Sports Utility Vehicles Patriot Chassis](#)
W Aryadi, Kriswanto, A Roziqin et al.



UNITED THROUGH SCIENCE & TECHNOLOGY

 **The Electrochemical Society**
Advancing solid state & electrochemical science & technology

**248th
ECS Meeting**
Chicago, IL
October 12-16, 2025
Hilton Chicago

**Science +
Technology +
YOU!**

**Register by
September 22
to save \$\$**

REGISTER NOW

Design and static structural analysis of a race car chassis for Formula Society of Automotive Engineers (FSAE) event

M L Mohamad, M T A Rahman, S F Khan, M H Basha, A H Adom and M S M Hashim

Mechanical Engineering Programme, School of Mechatronic Engineering, Universiti Malaysia Perlis (UniMAP) Pauh Putra Campus, 02600 Arau, Perlis, Malaysia.

tasyrif@unimap.edu.my

Abstract. The main purpose of this study is to make improvement for the UniMAP Automotive Racing Team car chassis which has several problems associated with the chassis must be fixed and some changes are needed to be made in order to perform well. This study involves the process of designing three chassis that are created based on the rules stated by FSAE rules book (2017/2018). The three chassis will undergo analysis test that consists of five tests which are main roll hoop test, front roll hoop test, static shear, side impact, static torsional loading and finally one of them will be selected as the best design in term of Von Mises Stress and torsional displacement. From the results obtained, the new selected chassis design which also declared as the new improved design poses the weight of 27.66 kg which was decreased by 16.7% from the existing chassis (32.77 kg). The torsional rigidity of the improved chassis increased by 37.74%.

1. Introduction

In automobile, chassis is one of the important parts of car because chassis is a skeletal edge that holds much type of different mechanical parts such as the suspension system, braking and handling, power train, engine, body and tires [1]. Poor chassis design and strength may lead to failure for other mechanical parts to function well. Therefore, chassis can be called as backbone to all the car system [2]. Just like human body which the backbone plays an important role in holding other body organ, muscle and skin. The other main function of a car chassis is to deal with the dynamic and static load which is applied to the chassis with the hope that the chassis will have less failure such as distortion and deflection due to the load.

The basic foundation of the FSAE chassis car is that the supporting chassis to which the engine and other mechanical parts are fastened [3]. The new design must undergo several testing before it will be develop. This is important to guarantee the best performance of the new chassis with less failure due to applied load during racing [4]. In order to design new chassis, the method should follow the guidelines set by FSAE (Formula Society Automotive Engineering) International. All the guidelines are already mentioned in the 2017-2018 Formula SAE Rules [5]. The regulation does not make the burden because it involves the driver's safety apart to teach engineering students to apply what they have learn in lecture and make practice on their skills [4],[6].



The FSAE car chassis must be rigid enough because it has to withstand vibration, twist, buckling, shock and many other stresses. Other than strength issue, the chassis design must be good enough to allow adequate bending and torsion stiffness in order to improve the handling system [5]. To make sure the good chassis are created, the design of chassis, ability of the chassis to handle load with less failure, ergonomics issue, weight [7] and ability to withstand several stresses must be consider while making the chassis.

In the existing FSAE car chassis, the chassis is too heavy due to the design that is too dense and many unimportant structures also cause in increasing the weight. Second problem is the engine bay and cockpit is too narrow causing problem when installing engine and the narrow cockpit affecting the driver's comforts. The existing design also is inappropriate due to loads that are not properly distributed along the chassis.

Many researches develop their own methods in order to make an analysis test of their chassis design. In designing process, there are many type of software that are used while designing the chassis. Some of the researchers use CATIA V5 software [1, 6, 8-11], AutoCAD [4], Solidwork [6], Pro-E [12]. Every CAD software used to design chassis have their own advantages and disadvantages, but most of the researches prefer to use CATIA V5 software because CATIA is better at complex bended surfaces and is utilized widely and maybe only as a part of the aviation and automotive enterprises [8]. For analysis test, there are many software that can be used for gaining the precise analysis data. Familiar analysis software that always be used by researches are ANSYS [1-4, 7, 10], and LS-DYNA [7, 9].

2. Materials and methods

2.1. Materials

The selection of material must not against the rules that stated in FSAE 2017-2018 Rules Book [5]. In the previous study, steel that always been used was Steel Grade ASTM A36 due to its suitability in many factors. This material is always be the best choice because of its availability, relatively low cost steel compare to others such as stainless steel and aluminium, and what is more importance than other factors is the ability of the material to handle certain load and impact if sudden load is applied to the material [14]. For this study, the same kind of material is used because it is easy to be welded with any type of welding such as Shielded Metal Arc Welding (SMAW), Metal Inert Gas (MIG) and Gas Tungsten Arc Welding (GTAW) and will produce high quality join [12]. In machining process, this type of steel is good for machining process because the rate is calculated to be more than 72%. The average of surface cutting feed is around 120 feet per minute [12].

2.2. Method Used

The study of chassis consists of several processes before full results can be obtained. Proper method must be well planned and considered before and during the study process in order to achieve the objective and solve all the problems as stated. The process started by designing the chassis by considering the specification in the FSAE 2017/2018 rules book [6]. For this study, three different designs were created. The chassis design can be referred in the Figure 1.

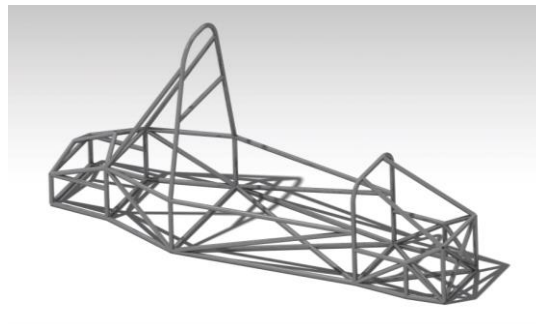

(a): Existing design

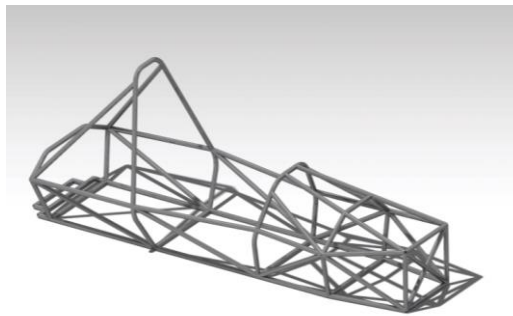

(b): Design 1

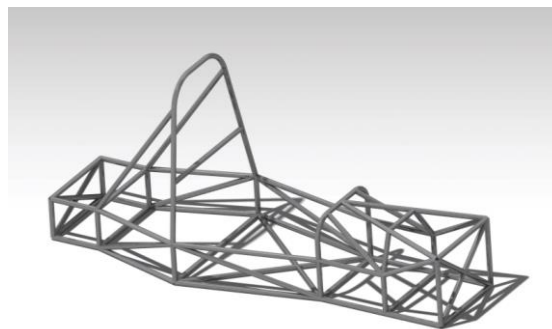

(c): Design 2

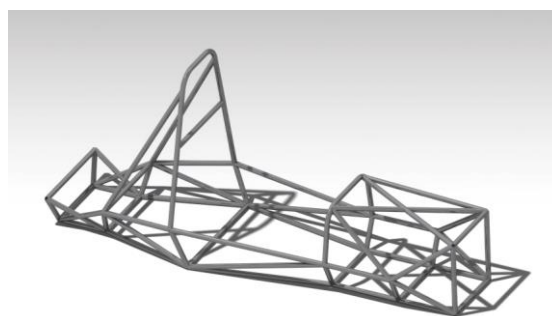

(d): Design 3

Figure 1. Chassis designs of UniART Racing Car.

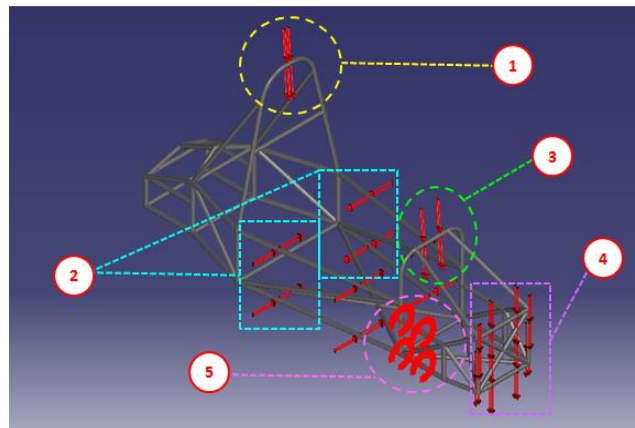

Figure 2. Load applied to different parts of chassis designs.

Based on Figure 2, Number 1 shows the load applied at the top of main roll hoop with the load in x, y and z-axis of 6.0kN, 5.0kN and -9.0kN respectively. The boundary condition for this test is by fixing the both bottom structure of front and main roll hoop. By referring to Number 2, the loads are applied towards the driver with loads of 7.0kN in y-axis direction. The boundary condition is by clamping both front and rear suspensions. Number 3 shows the loads applied at the top of front roll hoop with the same loads value and boundary condition as Number 1, while Number 4 shows the loads applied in downwards direction at the front bulkhead with value of -12.0kN. The boundary condition before this analysis test can be performed is by clamping the rear suspensions. The load applied in Number 5 is for static torsional loading test. The loads are applied at the right of side impact with moment value of 3.16kN.m. Initial condition involve in this test is by clamping rear suspensions while one side of front suspension is left unclamped. The entire analysis test, their boundary condition and load applied are summarised in Table 1 below.

Table 1. Summary of Analysis Test on Chassis Designs.

No	Analysis Test	Boundary Condition	Load Applied
1	Main Roll Hoop	Clamp the bottom structure of both main and front roll hoop.	$F_x = 6.0\text{kN}$ $F_y = 5.0\text{kN}$ $F_z = -9.0\text{kN}$
2	Side Impact	Both rear and front suspensions are clamped.	$F_y = 7.0\text{kN}$
3	Front Roll Hoop	Clamp the bottom structure of both main and front roll hoop	$F_x = 6.0\text{kN}$ $F_y = 5.0\text{kN}$ $F_z = -9.0\text{kN}$
4	Static Shear	Rear suspensions are clamped	$F_z = -12.0\text{kN}$
5	Static Torsional Loading	Rear suspensions are clamped and left side of front suspension is left unclamped.	$T = 3.16\text{kN.m}$

3. Results and Discussion

After an analysis has been made, all the results in term of Von Mises Stress and torsional displacement are compared in order to determine which one is the best. Results show that Design 1 is the best results in term of Von Mises Stress and torsional displacement. Below in Figure 3 show the analysis results that had been obtained during analysis test using CATIA V5 static structural analysis. The maximum value of Von Mises Stress and torsional displacement is represented by red colour.

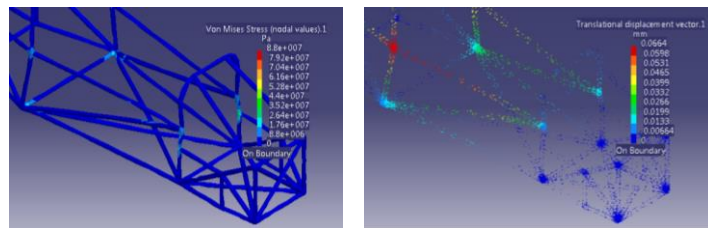

(a): Main roll hoop test

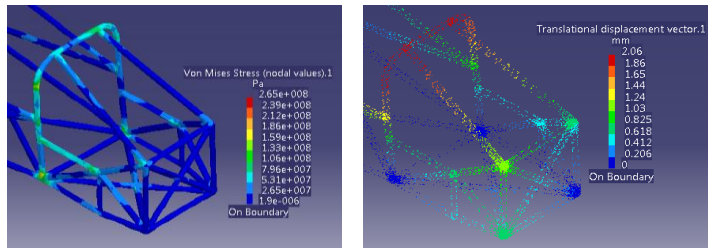

(b): Side impact test

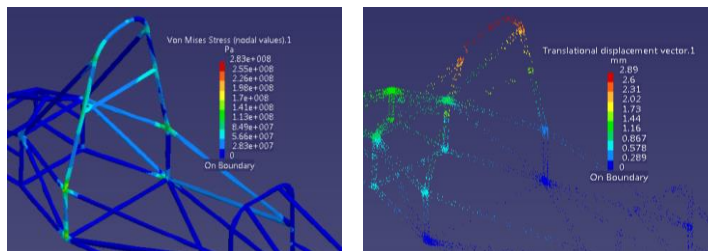

(c): Front roll hoop test

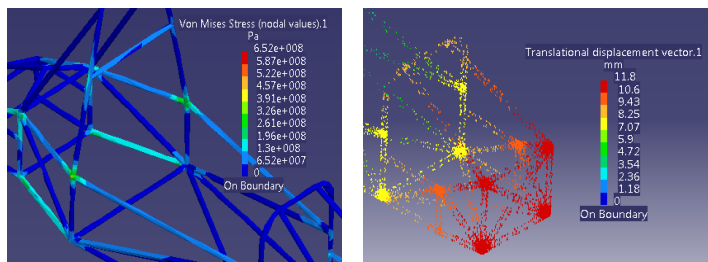

(d): Static shear test

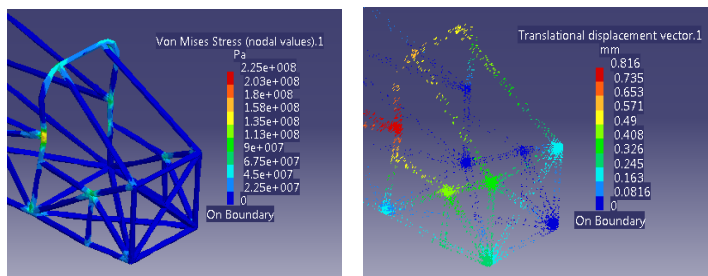

(e): Static torsional loading test

Figure 3. Von Mises stress and torsional displacement results for existing chassis.

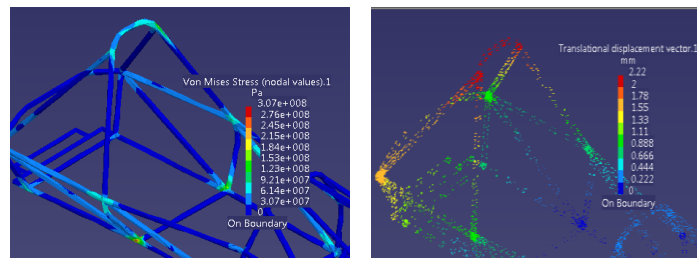

(a): Main roll hoop test

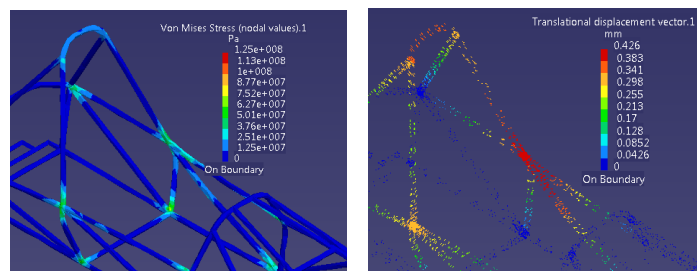

(b): Side impact test

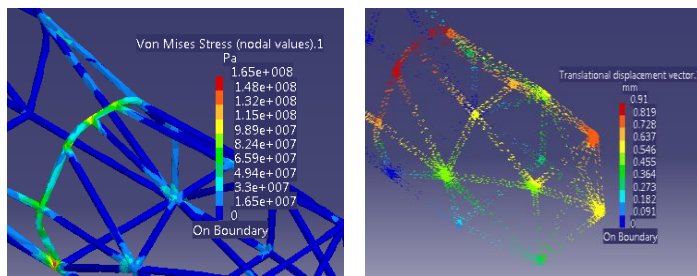

(c): Front roll hoop test

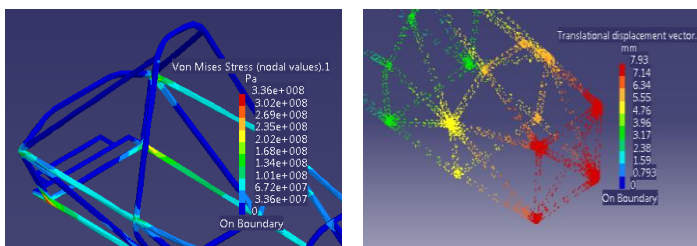

(d): Static shear test

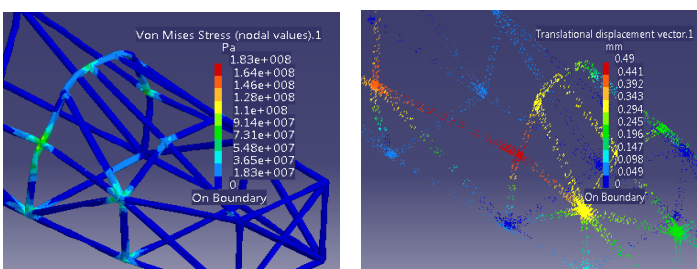

(e): Static torsional loading test

Figure 4. Von Mises Stress and torsional displacement results for improved chassis.

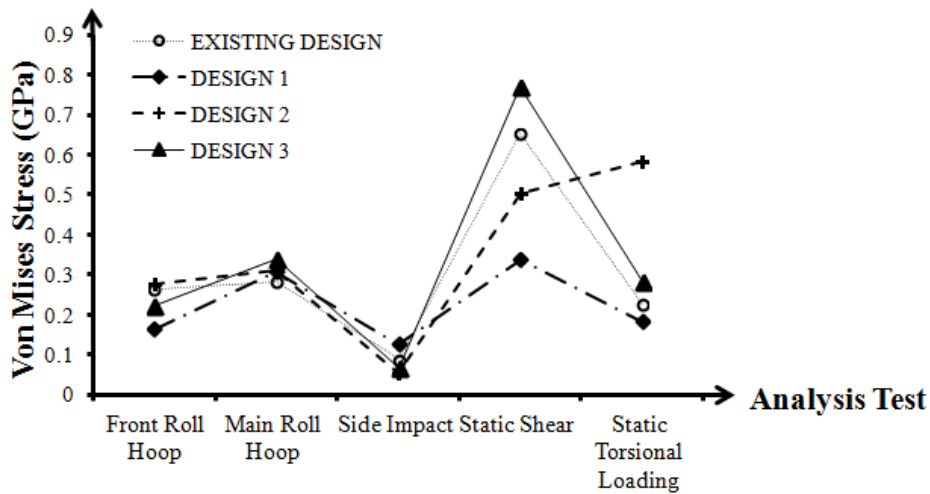

Figure 5. Graph of Analysis Test versus Von Mises Stress.

Figure 5 shows the graph obtained by plotting the type of analysis test versus the value of Von Mises Stress. By referring to the graph in Figure 4, the maximum value of Von Mises Stress for the existing design is 0.652GPa which is the second highest among all the designs. Design 2 poses the Von Mises value of 0.583GPa which is the third highest value comparing to the other three designs. For Design 1, the maximum value of Von Mises Stress occurred during static shear too which is 0.336GPa and can be considered as the lowest value among other designs based on the graph. Finally, for Design 3, the maximum value of Von Mises Stress which occurred during static shear is 0.769GPa which is the first highest value of Von Mises Stress among other designs. By comparing to all the maximum value of Von Mises Stress for each test in each design, Design 1 can be declared as the best design due to its lowest value of Von Mises Stress compared to other designs.

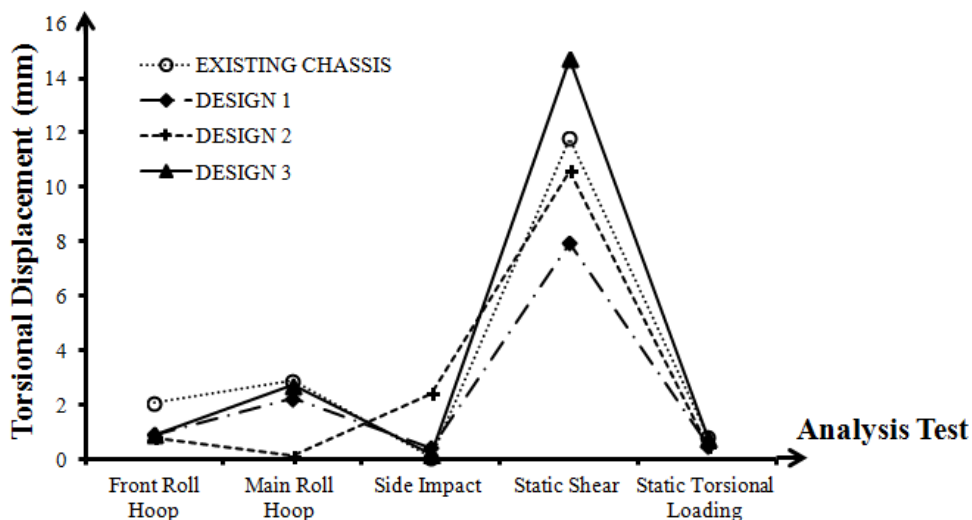

Figure 6. Graph of Analysis Test versus Torsional Displacement.

Figure 6 presents the whole graph results by plotting the type of analysis test versus torsional displacement which obtained during static structural analysis. By comparing to the maximum value of torsional displacement in each analysis test, the lowest value is considered as the best design. Existing design poses the maximum torsional displacement of 11.80 mm and the value is the second highest among the other three designs. Design 1 has the maximum displacement value of 7.930 mm that take

places as the lowest torsional displacement compared to other designs, while Design 2 has the maximum value of torsional displacement of 10.60 mm. Based on the graph, Design 2 is ranked as the third highest rank of torsional displacement. Finally, Design 3 has the value of torsional displacement of 14.70 mm and is ranked as the highest among other designs. By comparing all the data of torsional displacement, Design 1 can be considered as the best design because it poses the lowest value of maximum torsional displacement compared to the other three designs.

4. Conclusion

After all data had been obtained, and comparison in between the existing chassis and improved chassis had achieved a satisfactory level, conclusion can be made. Based on the new improved chassis design, the weight of chassis can be reduced by 16.7%. Unimportant structure can be eliminated thus helping in reducing weight too. Torsional rigidity of the new improved chassis is observed to be better which increased by 18.66% during static torsional loading test. The rigidity of front roll hoop is increased by 37.74% during front roll hoop test. Due to the satisfactory results of Von Mises Stress and torsional displacement, the new improved chassis is expected to perform well during racing.

5. References

- [1]. Rakesh Kumar Sahu, Suman Kumar Sahu, Srikant Behera, & V. Santosh Kumar (2016). Static Load Analysis of a Ladder Type Chassis Frame, *Imperial Journal of Interdisciplinary Research*, 2(5), 2454–1362.
- [2]. Juvvi Siva Nagaraju, & U. Hari Babu (2012). Design And Structural Analysis of Heavy Vehicle Chassis Frame Made of Composite Material By Varyin Reinforcement Angles of Layers, *International Journal of Advanced Engineering Research and Studies*, 1(2), 70–75.
- [3]. Naveen Ala, K. Tejdeep Reddy, & BVSS Bharadwaja (2016). Static Analysis of Truck Chassis using different materials, *International Journal of Innovative Research in Science, Engineering and Technology*, 5(1), 326–337.
- [4]. Prajwal Kumar M. P, Vivek Muralidharan, & G. Madhusudhana (2014). Design and Analysis of Tubular Space Frame Chassis of A High Performance Race Car, *International Journal of Research in Engineering and Technology*, 3(2), 497–501.
- [5]. 2016 SAE International. (2016, April 11). Retrieved November 28, 2016, from 2017-18 Formula SAE® Rules, <http://www.fsaeonline.com/content/2017-18/20FSAE/20Rules/20PRELIMINARY.pdf>
- [6]. Ravinder Pal Singh (2010). Structural Performance Analysis of Formula SAE Car. Chassis Loading 46–61.
- [7]. Kiran Ghodvinde, & S. R. Wankhade (2014). Structural Stress Analysis of an Automotive Vehicle Chassis, *International Journal on Mechanical Engineering and Robotics* 44–49.
- [8]. John Burrill, Ankit Dahiya, Ankit Sharma, & Syed Zillay Ali. (2015). What are the advantages of using CATIA? Retrieved November 28, 2016, from Quora, <https://www.quora.com/What-are-the-advantages-of-using-CATIA>
- [9]. Venkatesh S P, Mayur D Pawar, & Maruthi B H (2014). Design, Optimisation and Impact Analysis of a Chassis System of Race Car. *International Journal of Enhanced Research in Science Technology & Engineering*, 3(7), 377–386.
- [10]. Suraj B. Patil, & Dinesh G. Joshi (2015). Structural Analysis of Chassis : A Review. *International Journal of Research in Engineering and Technology*, 4(4), 293–295.
- [11]. A. Hari Kumar, & V. Deepanjali (2016). Design and Analysis of Automobile Chassis. *International Journal of Engineering Science and Innovative Technology*, 5(1), 187–195..
- [12]. Vijayan, Sendhilkumar, & Kiran Babu (2015). Design and Analysis of Automotive Chassis Considering Cross-Section and Material. *International Journal of Existing Research*, 7(5), 15697–15701.